



INSTALLATION INSTRUCTIONS FOR PART GM05-04

GM05-04

GM amplified OnStar Class II Data Bus *Interface 2000-up*

APPLICATIONS

See inside front cover

KIT FEATURES

- Provides accessory (12-volt 10-amp)
- Retains R.A.P. (retained accessory power)
- Used in amplified systems
- Retains chimes
- Provides NAV outputs (parking brake, reverse, mute, V.S.S.)
- ASWC-1 harness included (ASWC-1 not included)
- Retains OnStar/OE Bluetooth
- Adjustable volume for chimes and OnStar
- High level speaker input
- USB updatable
- Retains balance and fade

INTERFACE COMPONENTS

GM05-04 interface • 16-pin harness with stripped leads • 18-pin harness to 12- and 24-pin GM harness with stripped leads

TOOLS REQUIRED

• Cutting tool • Crimping tool • Tape • Connectors (example: butt-connectors, bell caps, etc.)

CAUTION: *Metra recommends disconnecting the negative battery terminal before beginning any installation. All accessories, switches, and especially air bag indicator lights must be plugged in before reconnecting the battery or cycling the ignition.*

NOTE: *Refer to the instructions included with the aftermarket radio.*



GM05-04

Applications

(Note: This interface will also work in vehicles listed below that are not equipped with OnStar.)

BUICK

Allure	2005-2009
Century	2004-2005
LaCrosse	2005-2009
Rainer	2004-2007
Regal	2004
Rendezvous	2002-2007
Terraza	2005-2008

CADILLAC

Escalade	2003-2006
Escalade ESV/EXT	2003-2006

CHEVROLET

Avalanche	2003-2006
Cavalier	2000-2005
Corvette	2005-2013
Impala	2000-2005
Malibu	2001-2003
Malibu Classic	2004-2005
Monte Carlo	2000-2005
Silverado	2003-2006
Silverado Classic	2007
SSR	2003-2006
Suburban	2003-2006
Tahoe	2003-2006
Trailblazer	2002-2009

GMC

Envoy	2002-2009
Sierra	2003-2006
Sierra Classic	2007
Yukon/XL/Denali	2003-2006

HUMMER

H2	2003-2007
H3/H3t	2006-2010

ISUZU

Ascender	2003-2008
----------	-----------

OLDSMOBILE

Alero	2001-2004
Bravada	2002-2004
Intrigue	2002

PONTIAC

Aztec	2001-2005
Grand Am	2001-2005
Grand Prix	2004-2008
Sunfire	2000-2005

SAAB

9-7x	2005-2009
------	-----------

SATURN

Relay	2005-2007
-------	-----------

Connections to be made

From the 16-pin harness:

- Connect the **Red** wires to the ignition wire of the aftermarket radio.
- Connect the **Orange/White** wire to the illumination wire of the aftermarket radio. If the aftermarket radio has no illumination wire just tape off the **Orange/White** wire.
- Connect the **White** wire to the left front positive speaker output of the aftermarket radio.
- Connect the **White/Black** wire to the left front negative speaker output of the aftermarket radio.
- Connect the **Gray** wire to the right front positive speaker output of the aftermarket radio.
- Connect the **Gray/Black** wire to the right front negative speaker output of the aftermarket radio.
- Connect the **Green** wire to the radio's left rear positive speaker output.
- Connect the **Green/Black** wire to the radio's left rear negative speaker output.



GM05-04

Connections to be made

- Connect the **Purple** wire to the radio's right rear positive speaker output.
- Connect the **Purple/Black** wire to the radio's right rear negative speaker output.
- Connect the **Blue/White** wire to the radio's amp turn on wire (this wire must be connected to hear sound from the factory amplifier).
- Connect the **Brown** wire to the mute wire of the aftermarket radio. If the aftermarket radio does not have a Mute wire, tape up the **Brown** wire (note, if the mute wire is not connected, the radio will turn off when OnStar is active).

The following wires are for aftermarket radios that have navigation built in:

- Connect the **Light Green** wire to the parking brake wire of the aftermarket navigation radio.
- Connect the **Blue/Pink** wire to the VSS or speed sense wire of the aftermarket navigation radio.
- Connect the **Green/Purple** wire to the reverse wire of the aftermarket navigation radio.

- Plug the 16-pin harness into the GM05-04.

From the 24-pin harness:

- Connect the **Yellow** wire to the radio's 12-volt battery or memory wire.
- Connect the **Black** wire to the radio's ground wire.
- Plug the 18-pin harness into the GM05-04.
- The **Black/Yellow** wire is for the OnStar volume adjustment. This will be discussed in the OnStar Level Adjustment section of this instruction.

The 12-pin harness (ASWC-1 plug) will be discussed later in the manual.



GMOS-04

Connections to be made

For Corvette 2005-2013 only (Figure A):

- A relay (Metra part number E-123) is needed in the Corvette 2005-2013. You will need to cut the **Blue/White** wire in half between the 18-way Molex and 24-way **Gray** connector.
- Connect the **Blue/White** wire coming from the 18-way Molex to pin 85 of the relay.
- Connect the **Blue/White** wire coming from the 24-way connector to pin 30 of the relay.
- Connect pin 86 of the relay to ground.
- Connect pin 87 of the relay to fused 12-volt constant wire. Using tape or a wire, tie securely the relay from moving around the dash.

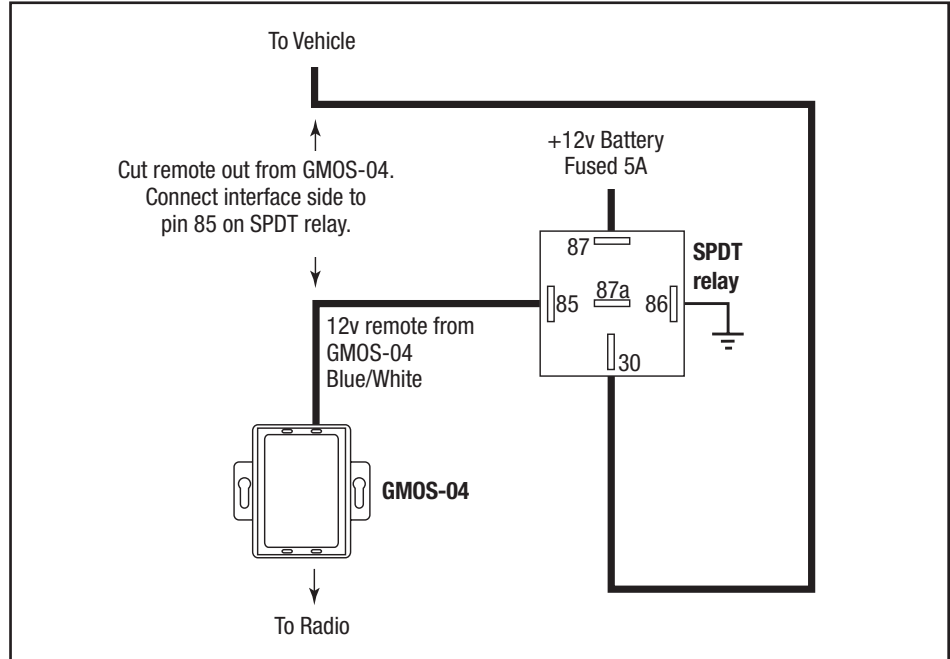

(Figure A)



GM05-04

Installing the GM05-04

- With all connections completed to the aftermarket radio, plug the 24- and 12-pin harnesses into the vehicles wiring harnesses.
- Reconnect the negative battery terminal.
- Cycle the key, by turning the ignition on for 30 seconds. Then off and on again to test the radio.

Testing the GM05-04

- 1) Turn the ignition on if not already, and then turn the radio on to verify that the radio works. Check balance and fader controls for proper operation.
- 2) Push the OnStar button (if equipped) to verify OnStar is working. The radio will shut off or mute, depending if the **Brown** wire on the 16-pin harness is connected, and OnStar will be heard through the front speakers. Turn off OnStar and the radio will turn back on.

Chime Volume Adjustment

Note: If Y91 is present on the RPO list, refer to your owner's manual to adjust chimes.

- 1) With car on, shut off car and leave keys in ignition. Open the car door and leave it open. Chimes will be heard.

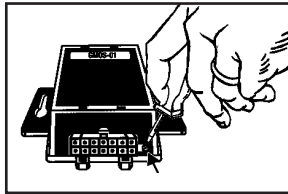

Potentiometer located on 16-pin side of the interface

Testing the GM05-04

- 2) Wait 10 seconds, then with a small screwdriver adjust the potentiometer fully counterclockwise (all the way left), then clockwise to raise chime level and counterclockwise to lower the chime level.
- 3) When the volume is at the desired level, remove the keys from the ignition. This will lock the chime volume at its current level.

Audio Level Adjustment

- 1) Start your vehicle and turn on the radio having audio playing.
- 2) Turn your aftermarket radio's volume up $\frac{3}{4}$ of the way.
- 3) With a small screwdriver adjust the potentiometer clockwise to raise the audio level and counterclockwise to lower the audio level.
- 4) Once at desired level your audio adjustment is complete.

OnStar Level Adjustment

To adjust the OnStar "volume up" or "volume down" on the steering wheel. If steering wheel controls are not present find the **Black/Yellow** wire on the 16-pin harness. Push the blue OnStar button, while the voice is speaking, tap the **Black/Yellow** wire to the ground. Once volume is set it will stay at the volume until the **Black/Yellow** wire is tapped to ground again. This can be set during installation and then left alone.



GM05-04

Additional 12-pin harness (ASWC-1 harness)

This 12-pin harness is to be used in conjunction with the ASWC-1 (not included). Please refer to ASWC-1 instructions for programming.

BUICK			
^Allure	2005-2009		
†Century	2004-2005		
†LaCrosse	2005-2009		
*Rainer	2004-2007		
†Regal	2004		
^Rendezvous	2002-2007		
^Terraza	2005-2008		
CADILLAC			
*Escalade	2003-2006		
*Escalade ESV/EXT	2003-2006		
CHEVROLET			
*Avalanche	2003-2006		
*Cavalier	2000-2005		
***Corvette	2007-2011		
^Corvette	2012-2013		
**Impala	2000-2005		
Malibu	2001-2003		
Malibu Classic	2004-2005		
**Monte Carlo	2000-2005		
*Silverado	2003-2006		
*Silverado Classic	2007		
*SSR	2003-2006		
*Suburban	2003-2006		
*Tahoe	2003-2006		
*Trailblazer	2002-2009		
GM			
*Envoy	2002-2009		
*Sierra	2003-2006		
*Sierra Classic	2007		
*Yukon/XL/Denali	2003-2006		
HUMMER			
H2	2003-2007		
ISUZU			
*Ascender	2003-2008		
OLDSMOBILE			
**Alero	2001-2004		
*Bravada	2002-2004		
**Intrigue	2002		
PONTIAC			
**Aztec	2001-2005		
**Grand Am	2001-2005		
**Grand Prix	2004-2008		
*Sunfire	2000-2005		
SAAB			
*9-7x	2005-2009		
SATURN			
**Relay	2005-2007		
* For the following vehicles please cut the White/Green, Green/Orange, and Orange/Green wires before programming the ASWC-1.			
** For the following vehicles please cut the White/Green, Pink, and Green/Orange wires before programming the ASWC-1.			
*** For the following vehicles please cut the Pink and Green/Orange wires before programming the ASWC-1.			
† For the following vehicles please cut the White/Green and Pink wires before programming the ASWC-1.			
Δ For the following vehicles please cut the Pink wire before programming the ASWC-1.			