



CAT-BACK EXHAUST INSTALLATION GUIDE: 2016+ CAMARO SS/ZL1

Thank you for purchasing the **AWE Touring Edition** or **Track Edition Exhaust System** for the **2016+ Chevrolet Camaro SS / ZL1**.

Let's go!

These instructions are intended for the following part numbers:

3020-32048, 3020-33052, 3015-32100, 3015-33100, 3020-32050, 3020-33054, 3015-32102, 3015-33102, 3020-42066, 3020-43074, 3015-42090, 3015-43112, 3020-42068, 3020-43076, 3015-42092, 3015-43114, 3010-11096

PARTS LIST



INSPECT ALL PARTS PRIOR TO DISASSEMBLY OF VEHICLE; IF DAMAGED OR MISSING, PLEASE CONTACT THE PLACE OF PURCHASE IMMEDIATELY.

OPTIONAL: Secondary Catalyst Delete Kit: RACE USE ONLY (SKU: 3010-11096)

- 1 2nd Cat delete section - driver (part B11)
- 1 2nd Cat delete section - pass. (part B12)

- 1 2 3/8" Barrel clamp

Conditional Mid-pipe Exhaust Parts:

- 1 Non-resonated section - driver (part B13)
- 1 Non-resonated section - pass. (part B14)

—OR—

- 1 Resonated section - driver (part B20)
- 1 Resonated section - pass. (part B21)

Exhaust Parts:

- 1 X-Pipe section (part B15)

NPP OPTIONS

Touring Edition Parts:

- 1 180Technology® rear section - driver (part B18)
- 1 180Technology® rear section - pass. (part B19)

Track Edition Parts:

- 1 Tailpipe section - driver (part B16)
- 1 Tailpipe section - pass. (part B17)

Hardware Kit:

- 4 4.5" slash-cut tips (optional finish)
- 2 2.75" Accu-Seal clamps
- 4 3.00" Accu-Seal clamps
- 4 3.0" Tip clamps

NON-NPP OPTIONS

Touring Edition Parts:

- 1 180Technology® rear section - driver (part B24)
- 1 180Technology® rear section - pass. (part B25)

Track Edition Parts:

- 1 Tailpipe section - driver (part B22)
- 1 Tailpipe section - pass. (part B23)

Hardware Kit:

- 2 4.5" slash-cut tips (optional finish)
- 2 2.75" Accu-Seal clamps
- 4 3.00" Accu-Seal clamps
- 2 3.0" Tip clamps



PRO-TIP: Installation of any exhaust should be performed by an experienced professional with the necessary equipment and know-how to effectively complete the install.

NPP LAYOUT:



NON-NPP LAYOUT:

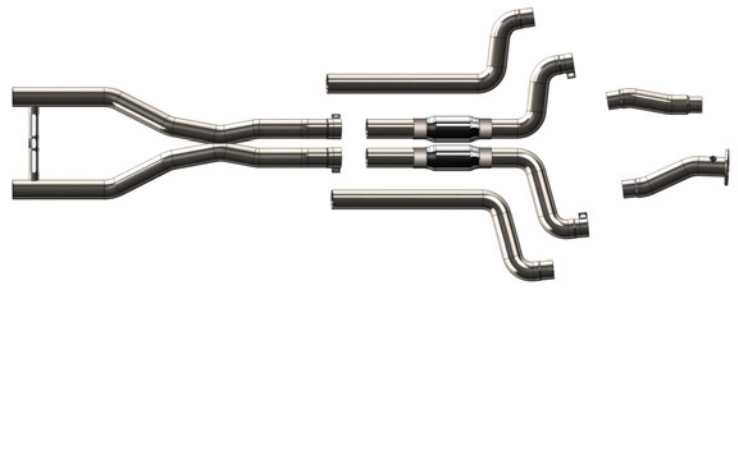

STEP 1



NOTE: The factory exhaust will need to be **CUT** from the car to install the AWE Performance Exhaust System, **unless** the 2nd Cat-delete Kit (3010-11096) has been purchased.



Always refer to the manufacturer service manual for precise torque specifications on all OEM fasteners.



WARNING: Allow the exhaust ample time to cool; serious injury and burns can occur if handled at operating temperature.

NPP Equipped Only:

Locate and unplug the factory valve control harnesses from the factory valve control motors, driver side location shown by the arrow in **Figure 1-1**, second motor is in the same location on passenger side.

Loosen and remove the chassis brace, shown by the arrow in **Figure 1-2**.

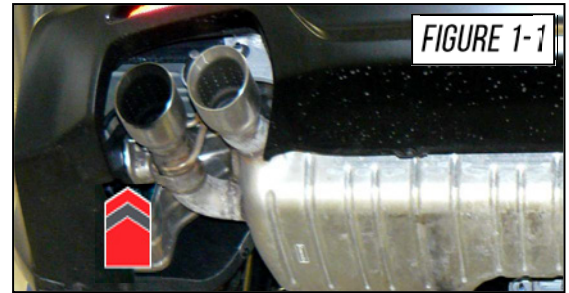

FIGURE 1-1

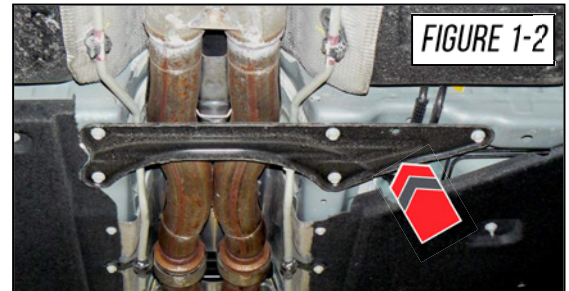

FIGURE 1-2

STEP 2



NOTE: Prior to exhaust removal, be sure the system is properly supported with pole jacks or recruit an extra set of hands to help.

Locate and spray the factory hanger bracket bolts with a penetrant oil to assist in removal, location shown by **Arrows A** in **Figure 2**.

Spray the hanger post and bushings with the same penetrant oil, locations shown by **Arrows B** in **Figure 2**.

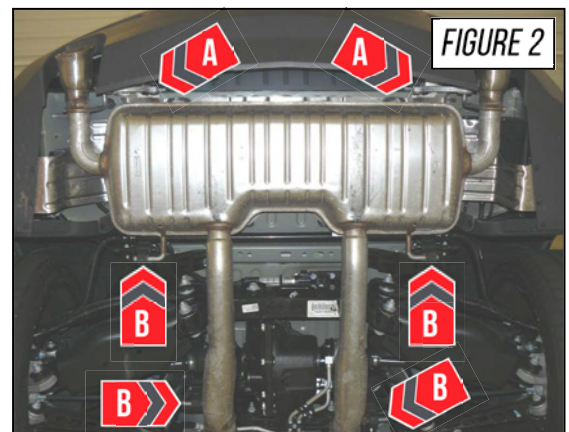

FIGURE 2

STEP 3



Secondary Cat-delete Kit installation only:

If the cat-back system has been purchased, skip to **Step 4**.

Locate and spray the factory clamp bolt with a penetrant oil to assist in removal, location shown by **Arrows A** in **Figure 3**.

Spray the flange bolts and post-cat O₂ sensor with the same penetrant oil, locations shown by **Arrows B** in **Figure 3**.

Loosen and remove the hardware and O₂ sensor.

The factory exhaust is ready to be removed, skip to **Step 5**.



PRO-TIP: O₂ sensors are important to how the car manages engine power; during removal, take measures to insure they do not get damaged or contaminated with dirt or debris.

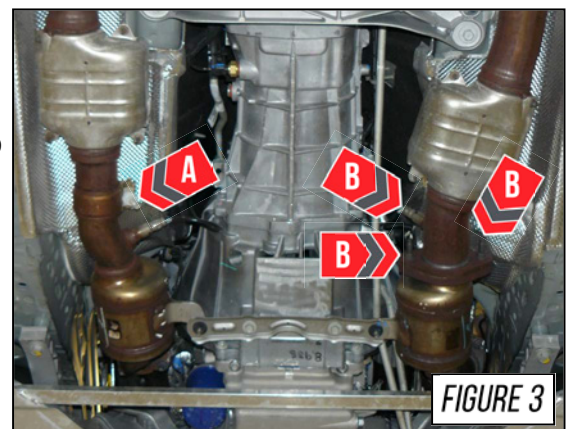

FIGURE 3

STEP 4

Marking & Cutting the Factory Exhaust:

PRO-TIPS:



- Use a metal-cutting saw or a chain-style pipe cutter to make the cuts outlined below.
- Masking tape can help provide a guide to make a straight cut.

Cutting the **DRIVER** side exhaust tube:

Measure from the edge of the weld, as shown by **Arrow A** in **Figure 4-1**.

Measuring 3-inches back (towards the rear of the car) from the weld, and mark with tape or a marker, as shown by **Arrows B** in **Figure 4-1**.

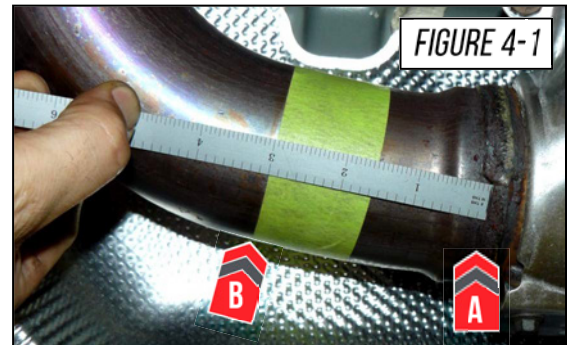

Cutting the **PASSENGER** side exhaust tube:

Measure from the edge of the weld, as shown by **Arrow A** in **Figure 4-2**.

Measuring 4-inches back (towards the rear of the car) and mark with tape or a marker, as shown by **Arrows B** in **Figure 4-2**.



NOTE: In order to achieve the best fitment and seal, these cuts must be as straight as possible.

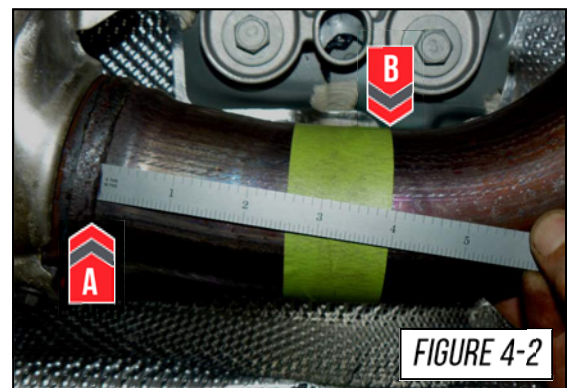

STEP 5



NOTE: Use a pole-jack or another person to help remove the factory exhaust.

If **Step 3** was performed:

Cut the bracket that secures the **driver side** clamp onto the outlet tube from the primary catalytic converter, located by the arrow, closer to the heat shielding, in **Figure 5-1**.

Exhaust removal:

Remove the rear muffler brackets and separate the bushings that were called out in **Step 2**, this will allow the factory exhaust to be removed from the vehicle.

If **Step 4** was performed:

Deburr the cut ends of the factory exhaust system, shown by the arrow in **Figure 5-2**.

For **NPP installations**:

Before installing the AWE Performance Exhaust, use an electrical tape to seal the open ends of the valve motor harnesses that were disconnected in **Step 1**.

Secure each harness up and out of the path of potential hot exhaust components or moisture.

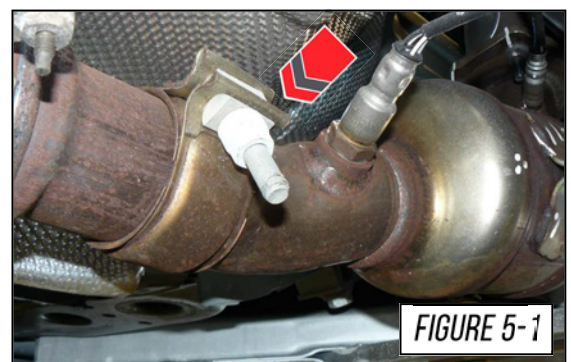

STEP 6



NOTE: If the AWE Performance Cat-Back System is being installed with the factory secondary cats, skip to Step 7.

Installing the AWE Secondary Catalyst Delete Kit:

Slide the included 2 ³/₈" barrel clamp over the inlet of the driver side 2nd cat delete section (*part B11*); and install as shown by **Arrow A** in **Figure 6**.

Using the factory flange gasket and nuts, install the passenger side 2nd cat delete section (*part B12*), as shown by **Arrow B** in **Figure 6**.

Reinstall the post-cat O₂ sensor, and torque to factory specification, shown by **Arrow C** in **Figure 6**.

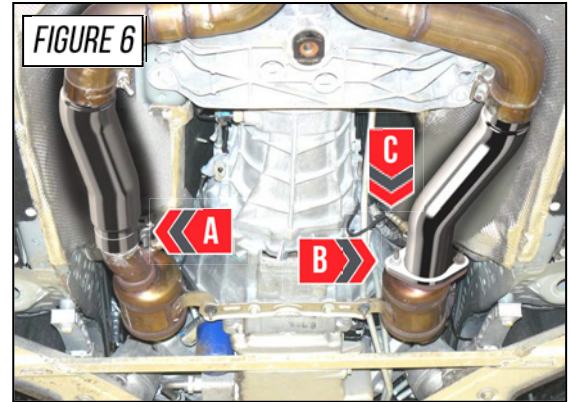

STEP 7

Installing the AWE Performance Cat-Back System:

Place the included 2.75" Accu-Seal clamp over the inlet of the driver side mid-pipe section (*part B13 or B20*) and install onto the corresponding outlet from the factory exhaust, as shown by **Arrow A** in **Figure 7**.

Place the final 2.75" Accu-Seal clamp over the inlet of the passenger side mid-pipe section (*part B14 or B21*) and install onto the corresponding outlet from the factory exhaust, as shown by **Arrow B** in **Figure 7**.



NOTE: DO NOT torque any clamps until the entire system has been installed and adjusted.

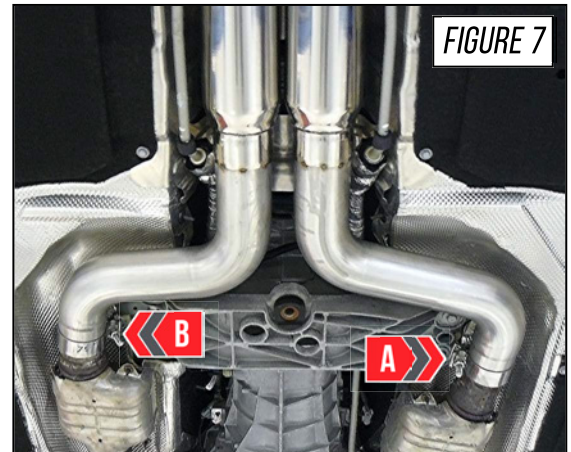

STEP 8

Use two (2) of the included 3.0" Accu-Seal clamps to install the X-pipe section (*part B15*).

Orient the clamps so that once the X-pipe is installed the clamps clear the chassis brace and are rotated as high as possible, as shown by **Arrow A** in **Figure 8-1**.



NOTE: Orienting the clamps correctly is needed in order to maintain current ground clearance. Ground contact may occur if the clamps are incorrectly placed.

Insert the posts, located at the outlet ends of the X-pipe section, into the hanger bushings as shown by the arrows in **Figure 8-2**.

Reinstall the chassis brace, as shown by **Arrow B** in **Figure 8-1**.

Torque all five (5) bolts for the chassis brace to factory specification.

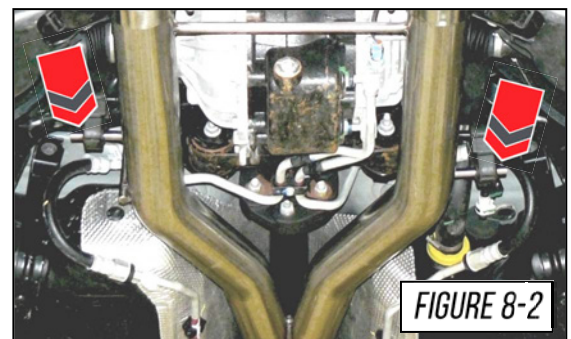
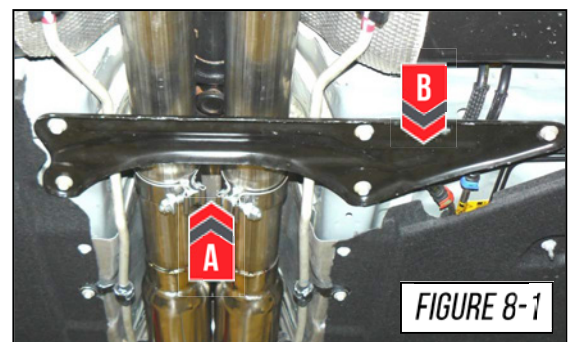

STEP 9

Place an included 3.0" Accu-Seal clamp over the driver side tailpipe section (*part B16, B18, B22 or B24*) and install onto the corresponding outlet on the X-pipe section, as shown by **Arrow A** in **Figure 9**.

Place the final 3.0" Accu-Seal clamp over the inlet side of the passenger side tailpipe section (*part B17, B19, B23 or B24*) and install onto the corresponding outlet on the X-pipe section, as shown by **Arrow B** in **Figure 9**.

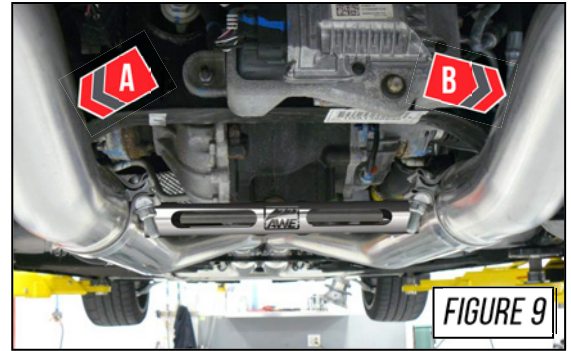

STEP 10

Transfer the hanger brackets from the factory muffler to the corresponding AWE Tailpipe Sections, as shown by the arrow in **Figure 10**.



NOTE: The factory hanger brackets are driver and passenger side specific, mixing them up will cause a fitment issue.

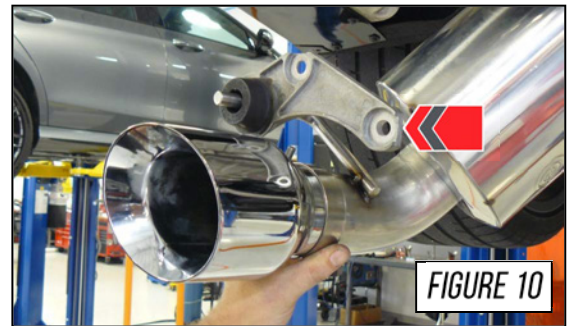

STEP 11

Reinstall the factory nuts to secure the hanger brackets into the original location, driver side shown by the arrow in **Figure 11**.

Torque to factory specification.

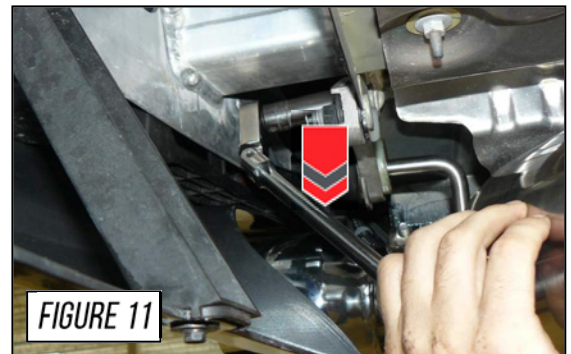

STEP 12

Insert the hanger bar, shown by **Arrow A** in **Figure 12**, into the factory hanger bushing shown by **Arrow B**.

Repeat for passenger side.

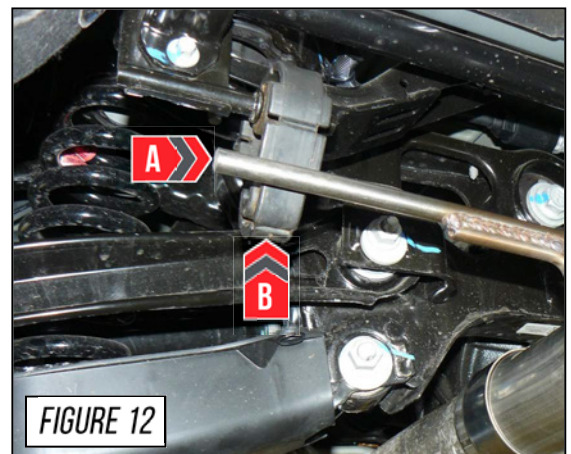

STEP 13

It is crucial to install each section and Accu-Seal clamp correctly to prevent loose joints and exhaust leaks between the tubing connections.

Arrow A in **Figure 13** shows the expanded pipe and the preinstalled Accu-Seal clamp being brought up to the corresponding pipe.

Arrow B in **Figure 13** shows the overlapping pipe installed correctly over the corresponding pipe.

Arrow C in **Figure 13** shows the Accu-Seal clamp being brought to the edge of the expanded pipe.



NOTES:

- Do not torque any Accu-Seal clamp until the entire exhaust has been installed and adjusted.
- Torque specification is a minimum of 40 ft/lbs.

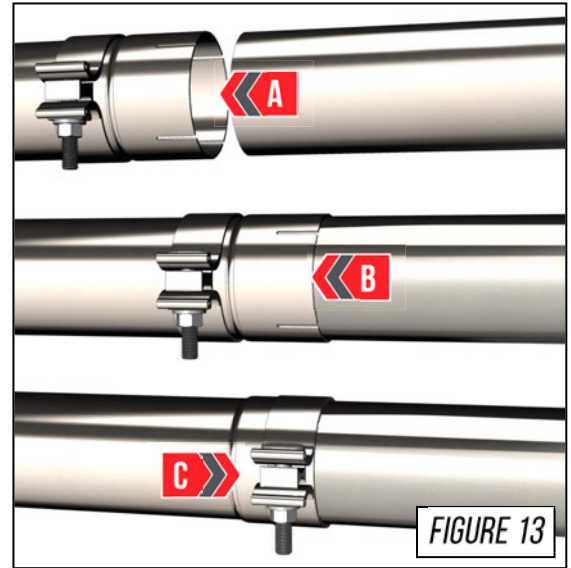

STEP 14

To accomplish the best tip fitment, align the 3.0" tip clamp to cover *only* the slot, as shown by **Arrow A** in **Figure 14**.

The clamp should only be covering the section of the tip that has been slotted, as shown by **Arrow B** in **Figure 14**.

Torque the tip clamp to a minimum of 18 ft./lbs.



NOTES:

- It is recommended to apply anti-seize to the threads to prevent thread binding, shown by **Arrow C** in **Figure 14**.
- It is okay to have the clamp extend beyond the edge of the tip inlet.

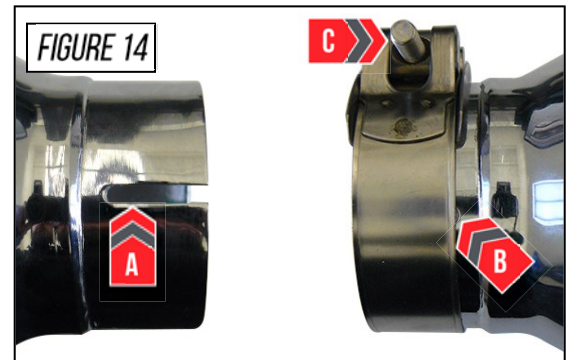

STEP 15

Using the remaining 3.0" tip clamps, install the 4.5" slash-cut tips as shown in **Figure 15**.

Do not torque the clamps until completely satisfied with placement.



STEP 16

Once tip and tailpipe alignment is satisfactory, torque the Accu-Seal clamps to specification, followed by the tip clamps.

Installation is complete!



ENJOY!

