

INSTALLATION GUIDE: AWE F90 M5 TRACK OR SWITCHPATH EXHAUST

THIS PRODUCT IS INTENDED FOR THE FOLLOWING VEHICLES*:

YEAR	MAKE	MODEL	SUBMODEL	ENGINE
2018-19	BMW	M5	Sedan	4.4L V8 Twin Turbo
2018-19	BMW	M5 Competition	Sedan	4.4L V8 Twin Turbo

THIS GUIDE IS INTENDED FOR THE FOLLOWING PART NUMBERS:

- 3020-11024 AWE Non-Resonated Performance Midpipe for BMW F90 M5
- 3020-42069 AWE Track Edition Axle-Back Exhaust for BMW F90 M5 - Chrome Silver Tips
- 3020-43077 AWE Track Edition Axle-Back Exhaust for BMW F90 M5 - Diamond Black Tips
- 3020-42070 AWE Track Edition Cat-Back Exhaust for BMW F90 M5 - Chrome Silver Tips
- 3020-43078 AWE Track Edition Cat-Back Exhaust for BMW F90 M5 - Diamond Black Tips
- 3025-42061 AWE SwitchPath Axle-Back Exhaust for BMW F90 M5 - Chrome Silver Tips
- 3025-43065 AWE SwitchPath Axle-Back Exhaust for BMW F90 M5 - Diamond Black Tips
- 3025-42062 AWE SwitchPath Cat-Back Exhaust for BMW F90 M5 - Chrome Silver Tips
- 3025-43066 AWE SwitchPath Cat-Back Exhaust for BMW F90 M5 - Diamond Black Tips

Welcome to the AWE family, and congratulations on your purchase of the **AWE Track Edition or Switchpath Edition Exhaust** system for the F90 M5.

Exquisite build quality and craftsmanship, coupled with industry leading performance, distinguish this exhaust system from all others.

PARTS LIST



INSPECT ALL PARTS PRIOR TO DISASSEMBLY OF VEHICLE; IF DAMAGED OR MISSING, PLEASE CONTACT THE PLACE OF PURCHASE IMMEDIATELY.

Performance Mid-Pipe (3020-11024)

QTY	Description	Part Number
2	F90 M5 Inlet Tubes	B77
1	F90 M5 Performance X-Pipe	B67
6	85mm Accu-Seal clamps	10-0798
2	3.00" Accu-Seal clamps	TAS300
2	80mm Coupler	B96

Axle-Back Exhaust

QTY	Description	Part Number
4	85mm Accu-Seal clamps	10-0798
1	F90 M5 driver side axle tube	B68
1	F90 M5 passenger side axle tube	B69
2	80mm Coupler	B96
2	3.00" Accu-Seal clamps	TAS300
4	Exhaust tip barrel clamps	BHM8X079SS00C
4	102mm Exhaust Tips	61000024(Chrome) or 61000024-BLK (Black)

Switchpath System Only

1	F90 M5 driver side Switchpath rear section	B72
1	F90 M5 passenger side Switchpath rear section	B83
2	Wiring Harness Extension for F90 M5	1325-11029

Track System Only

1	Driver side track rear section	B70
1	passenger side track rear section	B71
2	SBS valve simulator	150004
2	Valve motor pins	98380A457
4	Medium zip tie	7130K59

3/8" Hanger Clamp Kit (3910-11034)

2	3/8" exhaust hanger split collar	1C-037-A
1	7/64" Allen key	7122A17

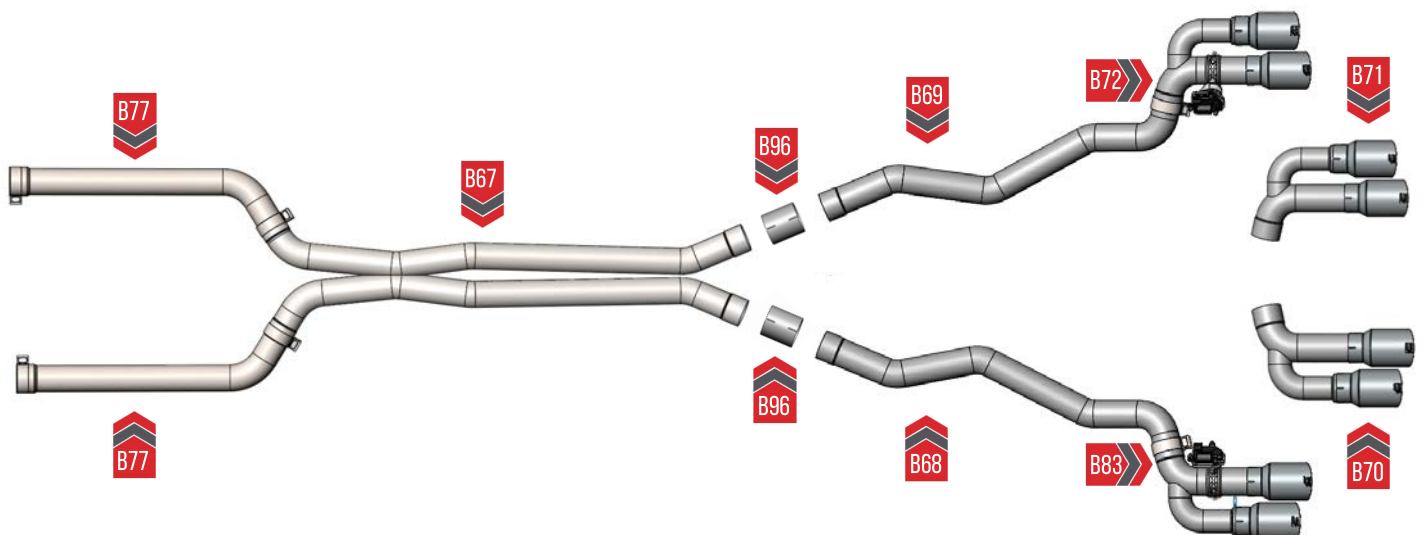

STEP 1

Installation of the AWE exhaust system is the reverse of the removal OEM exhaust.



Always refer to the manufacturer service manual for precise torque specifications on all OEM fasteners.



CAUTION: The exhaust may be **VERY HOT** — allow adequate time for the system to cool down before disassembly. Severe burns and injury will occur if skin comes into contact with a hot exhaust system.

Start by removing the rear OEM underbody shield shown in **Figure 1** and place it out of the way. These will be reinstalled after the AWE Exhaust is in place.

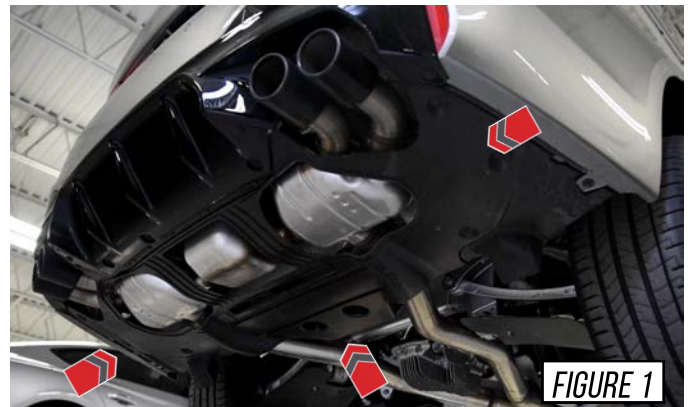

IF INSTALLING THE FULL CAT-BACK EXHAUST SYSTEM, SKIP TO STEP 3



STEP 2



The factory exhaust must be **CUT** from the car to install the AWE axle-back exhaust system. Reinstalling the factory exhaust will require the use of a sleeve clamp.

If installing the axle-back exhaust, locate the factory cut points marked by the dimples shown in **Figure 2**. Using pole jacks or jack stands, support the exhaust system and cut off the rear section.



When cutting the factory exhaust, make sure that the cut line is straight and remains perpendicular with the exhaust tube.

Deburr the cut ends of the factory midsection to ensure a clean joint.

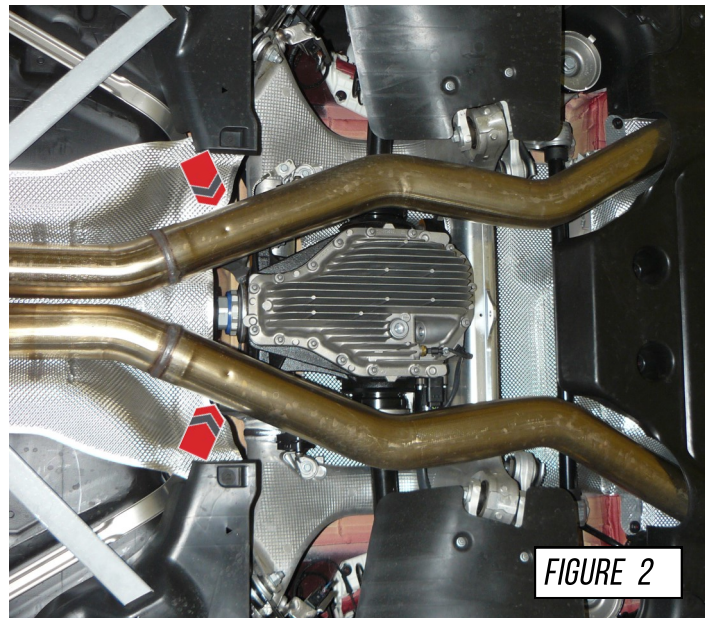

AXLE-BACK INSTALLATION INSTRUCTIONS RESUME ON STEP 5



STEP 3

Remove the two central chassis braces starting with the lower “X brace” as labeled by **Arrow A** in **Figure 3-1**.

The cross brace denoted by **Arrow B** in **Figure 3-1** should be removed as well leaving the exhaust system completely accessible as shown in **Figure 3-2**.

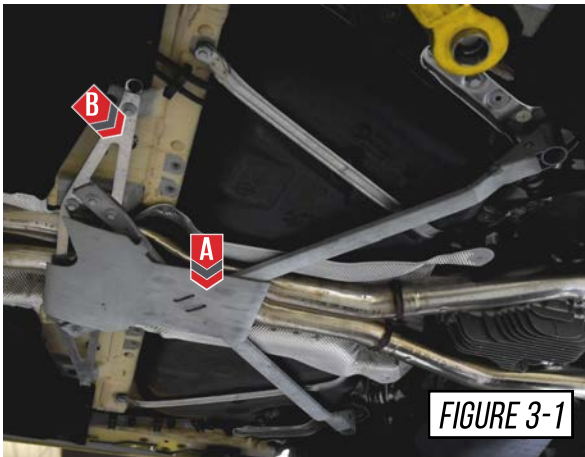

STEP 4

 **NOTE:** The OEM exhaust system should be safely supported before disassembly

Moving toward the front of the vehicle, loosen the two OEM exhaust clamps noted by the arrows in **Figure 4**.



STEP 5

 **NOTE:** The OEM exhaust system should be safely supported before disassembly

Remove the ground cable above the rear section on the driver side shown in **Figure 5** and tuck it out of the way.



STEP 6

Disconnect the factory valve motors from the harness by pinching and pulling out the plug. Do this for both the driver and passenger sides

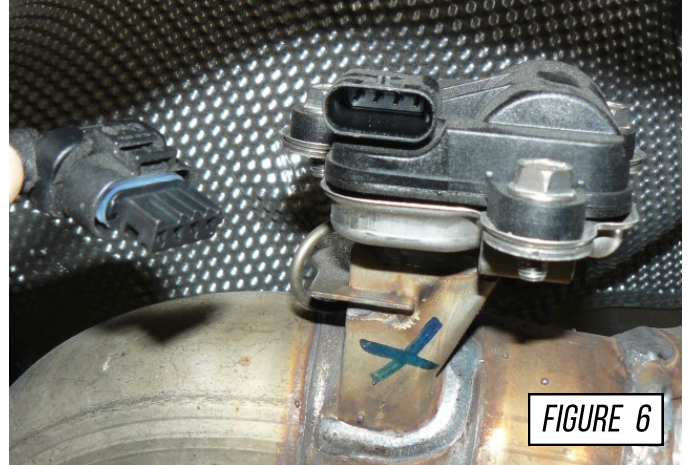

STEP 7

 **NOTE:** When removing hanger assemblies, we recommend unbolting the hanger bar bracket from the chassis as this makes it a bit easier to uninstall. This is shown in **Figure 7-1**.

Detach the four (4) OEM hangers shown by the arrows in **Figure 7-2** and remove the exhaust.

Install the hanger assemblies into the corresponding locations on the AWE exhaust.

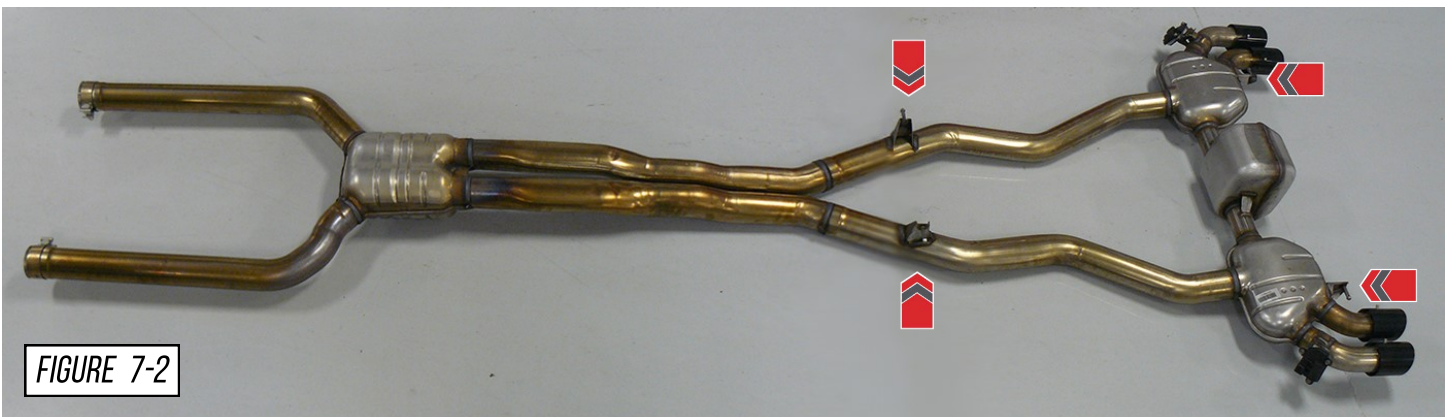
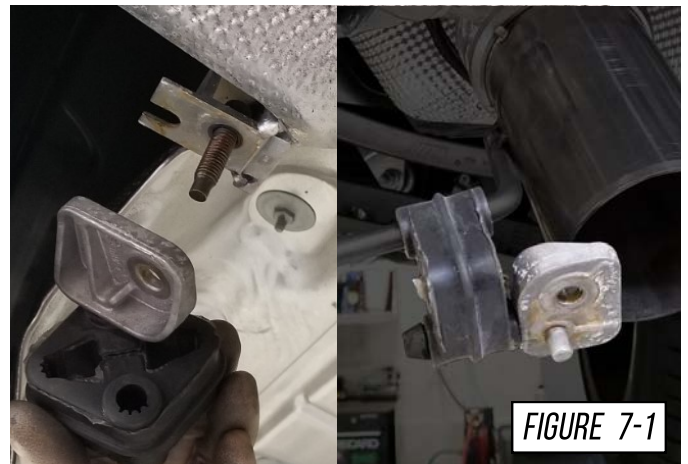

AXLE-BACK INSTALLATION INSTRUCTIONS RESUME ON STEP 12



STEP 8

While the parts are still off the vehicle, assemble the performance mid-pipe by installing the AWE exhaust inlet tubes (**B77**) onto the X-pipe (**B67**). Two (2) of the included 3" Accu-Seal clamps will be used.

 **NOTE:** The X-Pipe (**B67**) has a slight arc to it. When orienting the parts, this arc should point upward as shown in the side view in **Figure 8-2**. This will allow the system to have adequate clearance around the chassis braces.

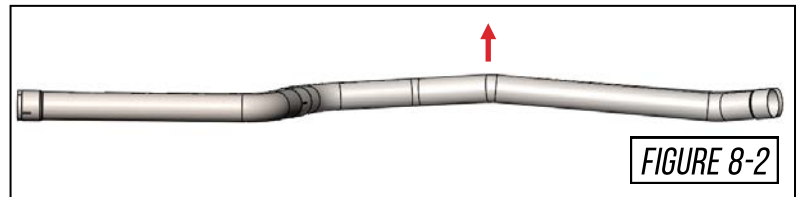
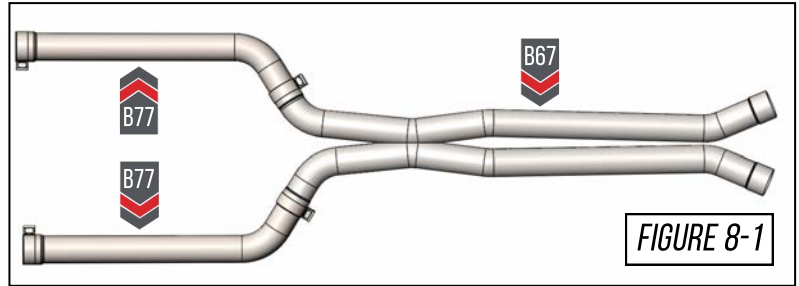

STEP 9

It is crucial to install each section and Accu-Seal clamp correctly to prevent loose joints, exhaust leaks between the tubing connections and rattles.

Arrow A in **Figure 9** shows the expanded pipe and the preinstalled Accu-Seal clamp being brought up to the corresponding pipe.

Arrow B in **Figure 9** shows the overlapping pipe installed correctly over the corresponding pipe.

Arrow C in **Figure 9** shows the Accu-Seal clamp being brought to the edge of the expanded pipe.

NOTES:

-  **Do not** torque any Accu-Seal clamp until the entire exhaust has been installed and adjusted.
- Torque specification is a minimum of 60 ft/lbs

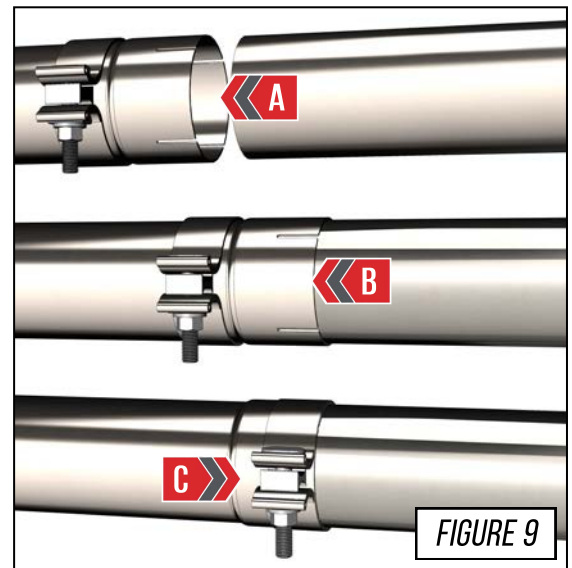

STEP 10

Attach the mid-pipe assembly constructed in step 8 to the factory catalytic converters using the included 85mm Accu-Seal clamps shown in **Figure 10**.

 **NOTE:** Remember to orient the mid-pipe so it matched the image in **Figure 8-2**.

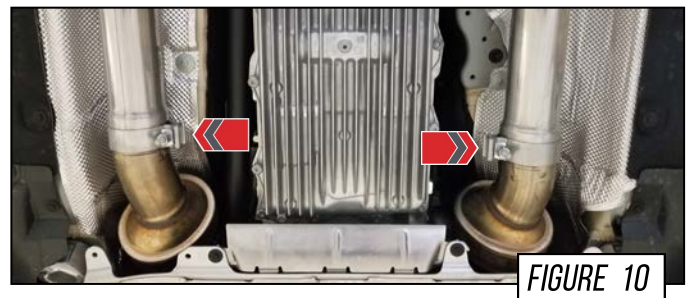

STEP 11

Reinstall the two chassis braces and the two underbody shields that cover them.

 Installing the chassis brace at this point can help support the front of the exhaust system while the rear is being installed. We still advise keeping the exhaust supported with a jack.

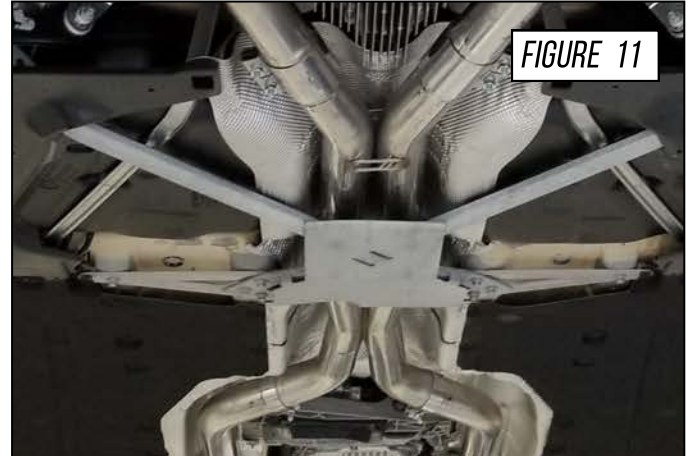

STEP 12

Slide two (2) 85mm Accu-seal clamps over the 80mm sleeve adapters (**B96**) shown in **Figure 12**. Place this assembly over the outlet end of the mid-pipes.

Next, slide the axle-tubes (**B68**) and (**B69**) into the other ends of the sleeve adapters.

Make sure to fully bottom out the tubes in the sleeve adapters and tighten the Accu-seal clamps only enough to hold the parts. We want to keep some room for final adjustments.

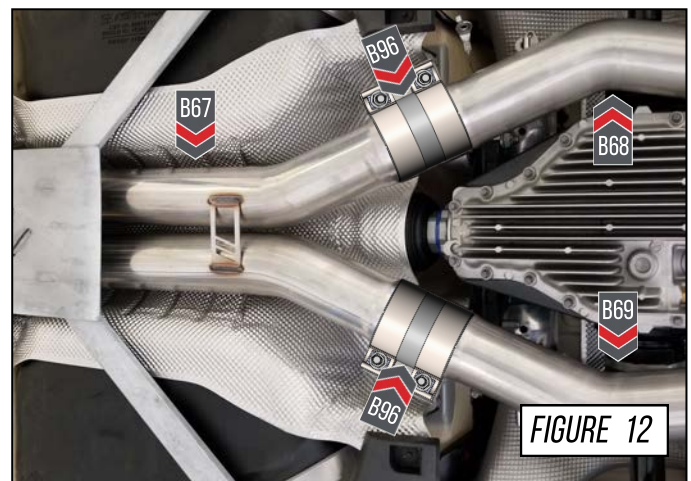

STEP 13

Optional: loosen heat shield to tuck valve wire harnesses away.

For Switchpath installation, you may need to install the included harness extension shown by **Arrow A** in **Figure 13**.



 **Switchpath instructions continue on step 15**

STEP 14

Valve Simulator Bracket Installation For Track Edition:

Remove each factory valve motor from the factory mounting location on the OE exhaust system.

NOTE: The pin shown in **Figure 14-1** is critical to the function of the valve simulator bracket. Make sure this is installed correctly.



Using the factory hardware, install the driver side valve motor onto one of the included valve motor brackets and pins, as shown in **Figure 14-1**.

Use a few cable-ties to secure the assembly up and away from the exhaust, as shown by **Arrow A** in **Figure 14-2**.

Reconnect the factory harnesses to the valve control motors, as shown by **Arrow B** in **Figure 14-2**. Repeat the valve simulator bracket installation for the passenger side.

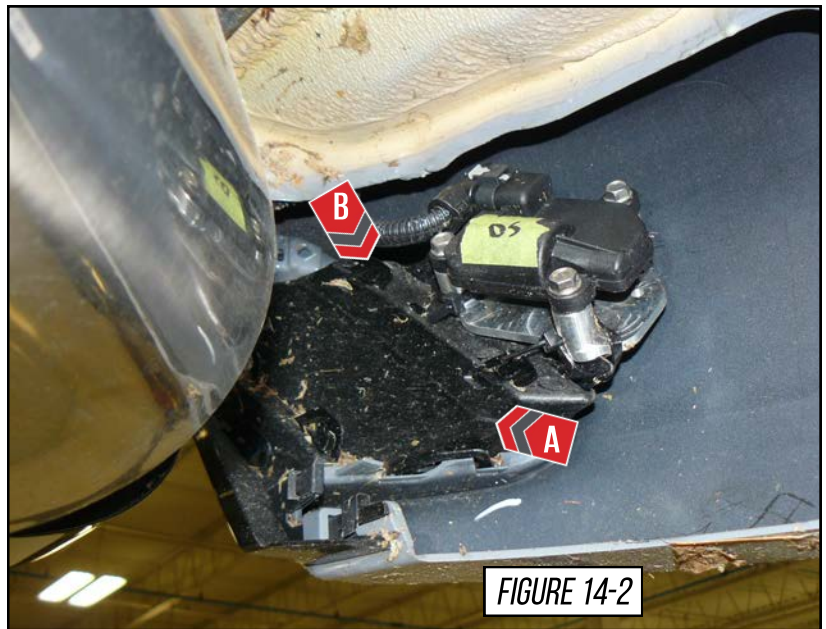
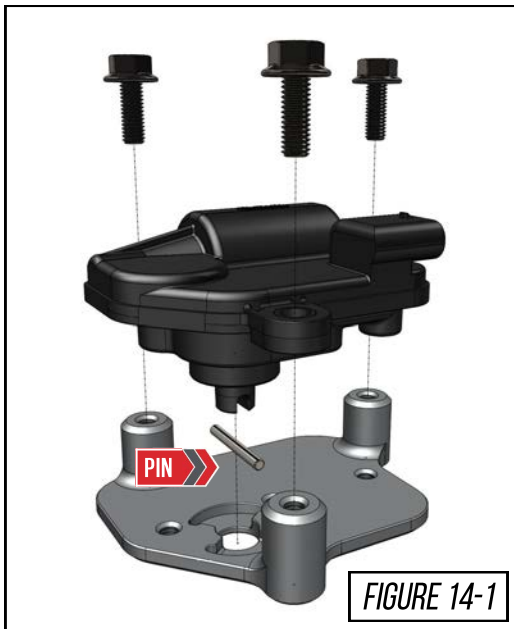

WARNING: Do not power up the vehicle or the valve motors while the motor is disconnected or re-indexing will be required. Consult your vehicle manufacturer for re-indexing instructions



STEP 15

Place one of the 3in Accu-seal clamps shown by **Arrow A** onto the ends of each axle tube before connecting the rear sections.

TIP: We like to attach the rubber hanger and hanger bracket (**Arrow B**) onto the exhaust tube before installation since it is easier to access while the part is off the vehicle.

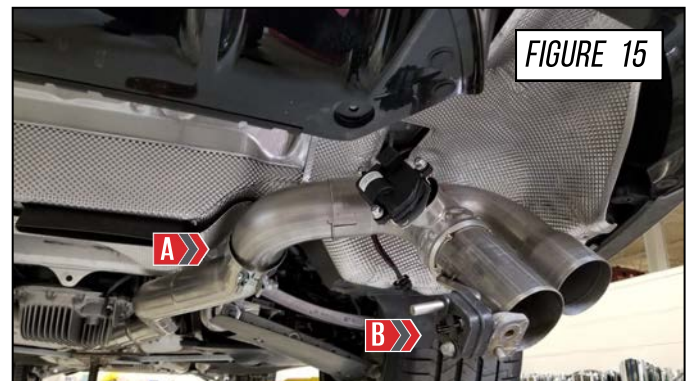

STEP 16

When installing the Switchpath system, rotate the rear sections into place so that there is at least 1/4" between the the valve motor and the heat shield as shown in **Figure 16**.

Plug the male end of the valve wiring harness into the valve motor until it clicks. Push the locking tab (**Arrow A**) in to secure the connection.



FIGURE 16

STEP 17

Using four (4) exhaust tip barrel clamps, attach the exhaust tips to the ends of the rear sections. The recommended torque settings for these barrel clamps are 18ft-lbs

 **NOTE:** Applying anti-seize to the bolt threads is required when loosening or tightening the barrel clamps.



STEP 18

Go back across the exhaust system to check for contact and tighten the Accu-seal clamps. Accu-seal clamps should be tightened to 60 ft-lbs and the tubes should be adjusted so that the tips sit evenly in the rear bumper. Reinstall the lower shroud and the installation is complete!



ENJOY!



TROUBLESHOOTING

Issue	Solution
Exhaust is not fitting correctly	Most fitment issues are due to improperly adjusted exhaust. This includes tip fitments and rattling due to chassis contact.
Wrong or missing parts	Double check the parts list for your system and compare them with what you received. Fill out our contact form, found below and let us know what parts you need.