

# Installation Instructions



## Ventvisor® Deflector

### Important Safety Information



- CAUTION - Before driving, ensure that the vent visors are properly secured to vehicle.
- Do not use automatic “brush-style” car washes.
- Do not use cleaning solvents of any kind.
- Periodically check all components for tightness.
- When using Surface Prep, avoid contact with skin. Use in well ventilated area. If contact is made with material, flush area with large amounts of water. If irritation persists, get immediate medical attention. USE PREP ON RUBBER ONLY

### Contents - 2 Piece Set

**NOTE:** Actual product may vary from illustration.

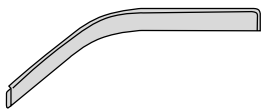

Front Driver Side Visor

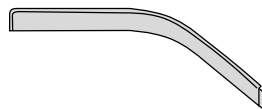

Front Passenger Side Visor



Alcohol Pad x2

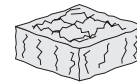

Scotch Brite Pad



Surface Prep x2

### Contents - 4 Piece Set

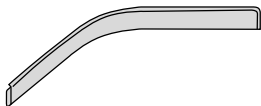

Front Driver Side Visor

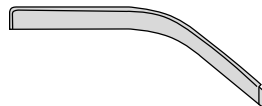

Front Passenger Side Visor



Rear Driver Side Visor



Rear Passenger Side Visor



Alcohol Pad x2



Scotch Brite Pad



Surface Prep

### Tools Required



Car Wash Supplies



Clean Towel

### Preparation Before Painting / Installation

- A trial fit is recommended to ensure proper positioning and fit.
- Check fit of parts before painting as we will not accept the return of modified or painted parts.
- Wash your vehicle to remove any debris and/or dirt.
- Dry with a clean towel.

# Installation Steps

**NOTE:** Actual application may vary slightly from illustrations.



Buff the top of the door trim with the scotch brite pad. Then clean trim and surface where visor will mount with an alcohol pad.

Alcohol Pad

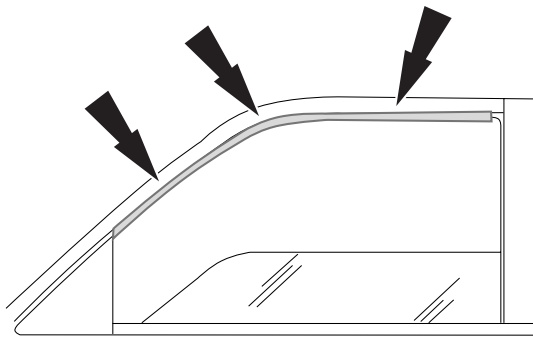

1



Apply one coat of surface prep to rubber trim. Prep rubber trim on both sides before installing visors.

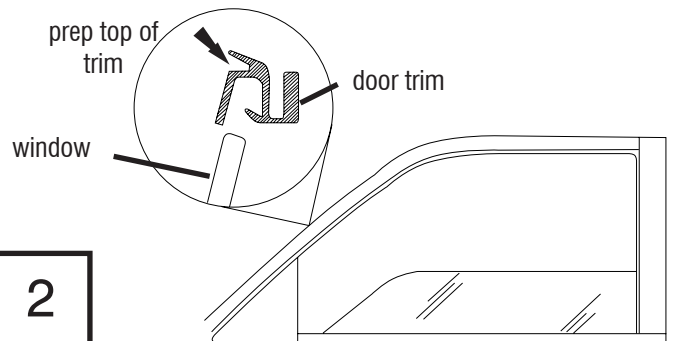

2

Peel back 2" (5cm) of tape liner from the front and rear flanges.

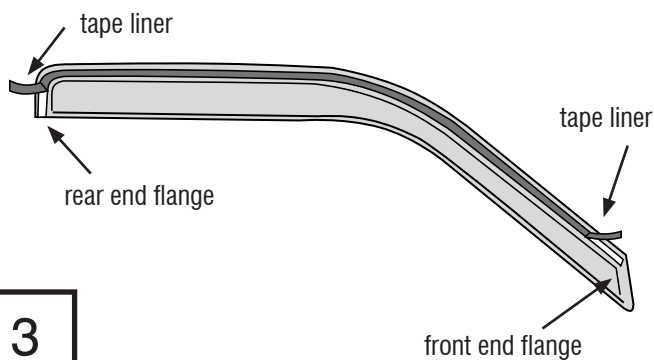

3

Align the driver side visor with previously cleaned door trim. Slide the front end flange under the mirror cap. Rear and lateral flanges attach directly to previously cleaned surfaces.

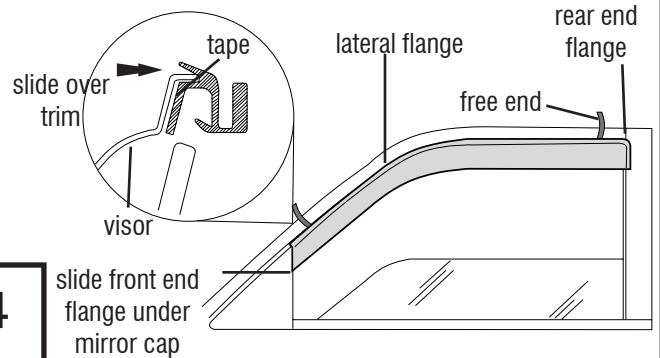

4

With the visor in its final position, remove the remainder of the tape liner by pulling on free ends.

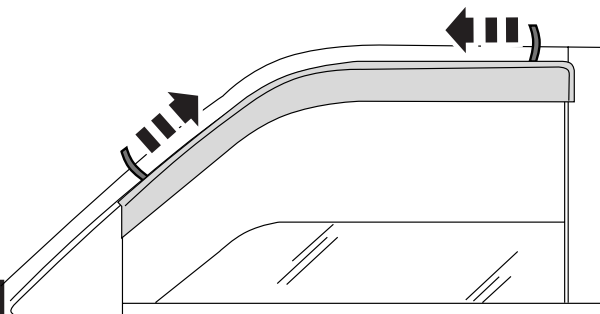

5

Apply pressure along flange edges to ensure proper adhesion.

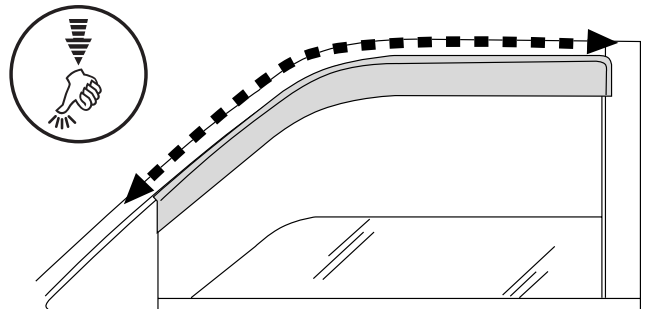

6

Repeat **Steps 1-6** for passenger side.

The rear visor attaches to the door trim following the same procedure as the front visor. Refer to the correct figure for your particular application.

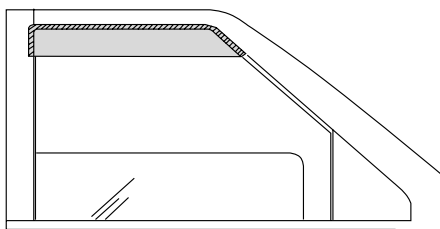

**figure 7a:** Dodge Intrepid

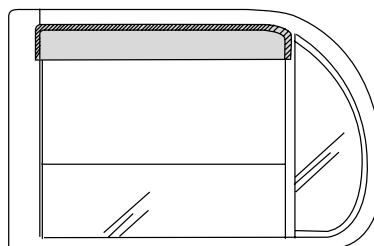

**figure 7b:** Chrysler LHS/New Yorker

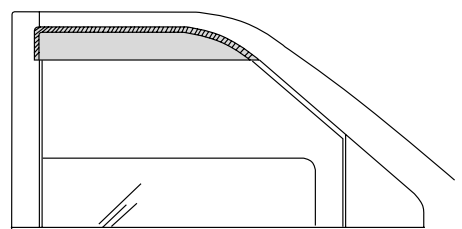

**figure 7c:** Eagle Vision/Chrysler Concorde

7

## Care and Cleaning

- Wash only with mild soap & dry with a clean cloth.



The material that your product is made from can be recycled. Please also consider recycling the packaging that your product came in.



## Congratulations!

You have purchased one of the many quality Auto Ventshade™ branded products offered by Lund International. We take the utmost pride in our products and want you to enjoy years of satisfaction from your investment. We have made every effort to ensure that your product is top quality in terms of fit, durability, finish and ease of installation.



Check out the collection of rain guards and wind deflectors we offer.