

Installation Instructions



AUTO VENT SHADE™

Ventvisor® Deflector

Important Safety Information



- CAUTION - Before driving, ensure that the vent visor is properly secured to vehicle.
- Do not use automatic "brush-style" car washes.
- Do not use cleaning solvents of any kind.
- Periodically check all components for tightness.

Contents **NOTE:** Actual product may vary from illustration.

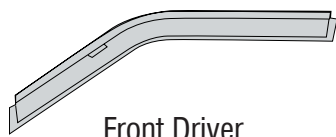

Front Driver Side Visor

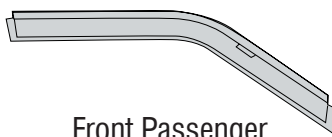

Front Passenger Side Visor



Alcohol Pad
x2



Scotch Brite pad

Tools Required



Car Wash Supplies

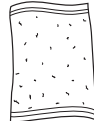

Clean Towel

Preparation Before Painting / Installation

- A trial fit is recommended to ensure proper positioning and fit.
- Check fit of parts before painting as we will not accept the return of modified or painted parts.
- Wash and dry your vehicle to remove any debris and/or dirt from the installation area.

Installation Steps **NOTE:** Actual application may vary slightly from illustrations.



Lower the drivers side window completely. Buff the **IN-SIDE** of the rubber window channel with the scotch brite pad, then clean with an alcohol pad. Dry with a soft cloth.

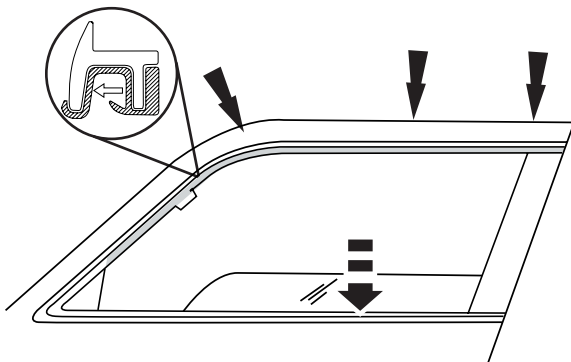

1

Peel back 2" of tape liner from each end of lateral flange.

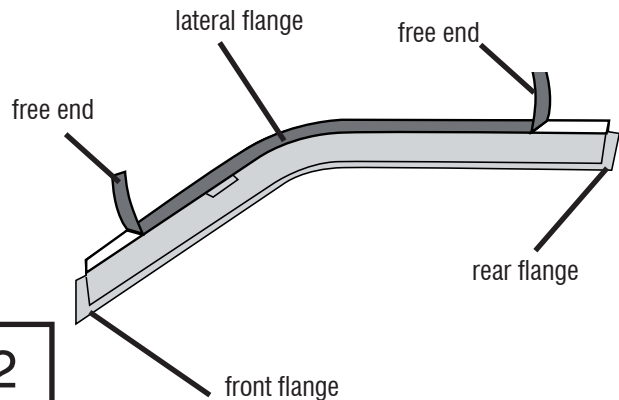

2

Installation Steps

NOTE: Actual application may vary slightly from illustrations.

Place the visor in the window frame, beginning at the front, flexing it slightly to insert the rear end flange. The front end flange will insert **BETWEEN** the rubber window channel and the mirror cap. Ensure the free ends are exposed.

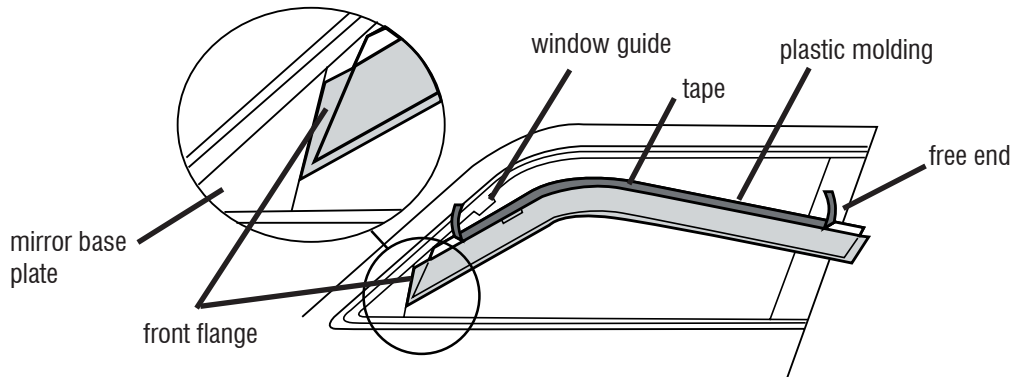

3

Use an adjustable wrench to loosen (but do not remove) the bolts located on the inside face at the rear of the front door. Slip the rear end flange **BETWEEN** the rubber window channel and the loosened trim panel. Retighten bolts.

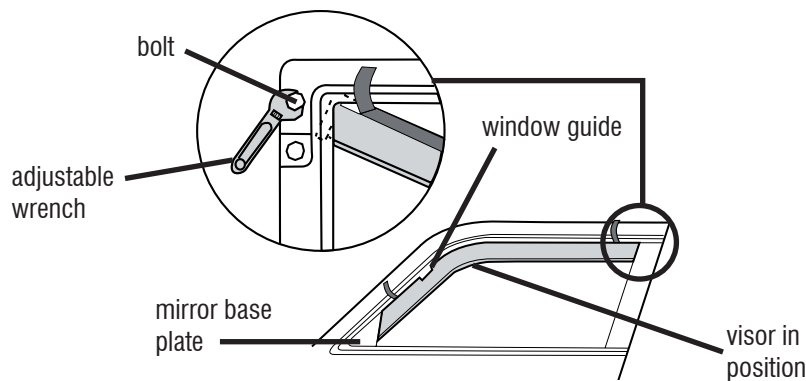

4

With the visor in its final position, remove the remaining tape liner by pulling on free ends.

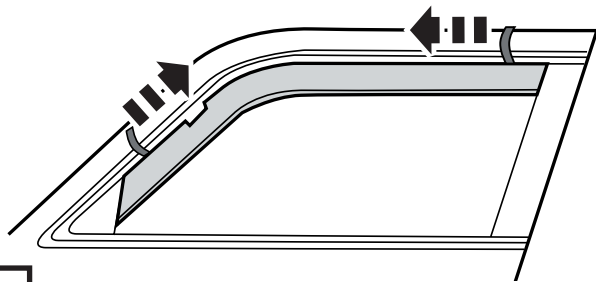

5

Apply pressure along all flanges to ensure proper adhesion of tape. Roll window back up and leave for 24 hrs for tape adhesive to cure.

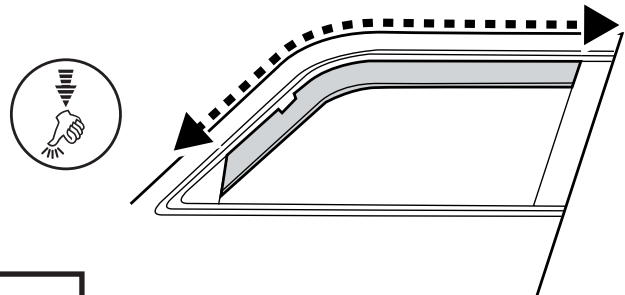

6

Repeat **Steps 1-6** for opposite side.

Care and Cleaning

- Wash only with mild soap & dry with a clean cloth.

Congratulations!

You have purchased one of the many quality Auto Ventshade™ branded products offered by Lund International, Inc. We take the utmost pride in our products and want you to enjoy years of satisfaction from your investment. We have made every effort to ensure that your product is top quality in terms of fit, durability, finish and ease of installation.



When it comes to quality rain guards and wind deflectors, AVS is the brand you can depend on.