



Automated Products International, LLC

Clamp Application Guide

MOUNTING SOLUTIONS™

Truck Model	Caps With Aluminum Rail	Caps With Fiberglass Rail	Lids
Dodge Dakota	AC101, KH1, SK1 or DA102	AC101, KH1, SK1 or DA102	AC105 or AC106
Dodge Ram	AC101, KH1, SK1 or DA102	AC101, KH1, SK1 or DA102	AC105 or AC106
Ford Ranger	AC101, KH1, SK1 or DA102	AC101, KH1, SK1 or DA102	AC105 or AC106
Ford Explorer Sport Trac	AC111US, AC111UM or AC111UL	AC111US, AC111UM or AC111UL	AC111USL, AC111ULL or AC111UXL
Ford F-Series 2004 and Newer	SK1030P4 or SK102030P6	SK2S	AC105 or AC106
Ford F-Series	AC101, KH1, SK1 or DA102	AC101, KH1, SK1 or DA102	AC105 or AC106
Ford Super Crew 2001	KH1-275 or SK1	KH1-275 or SK1	AC106-225
Ford F-Series ('97 & Newer)	AC1031 or SK2	AC1031 or SK2	AC105 or AC106
Ford F-Series Super Duty ('97 & Newer)	AC1031, SK2 or AC108	AC1031, SK2 or AC108	AC105 or AC106
Ford Flareside ('96 & Prior)	AC109US, AC109UM or AC109UL	AC109US, AC109UM or AC109UL	AC109USL or AC109ULL
Ford Flareside ('97 to 2003)	AC101, KH1, SK1 or DA102	AC101, KH1, SK1 or DA102	AC105 or AC106
Chevy S-10/Sonoma ('93 & Prior)	AC101, KH1, SK1 or DA102	AC101, KH1, SK1 or DA102	AC105 or AC106
Chevy S-10/Sonoma ('94 & Newer)	AC101, KH1, SK1 or DA102	AC101, KH1, SK1 or DA102	AC105 or AC106
Chevy C/K / GMC Sierra	AC101, KH1, SK1 or DA102	AC101, KH1, SK1 or DA102	AC105 or AC106
Chevy / GMC SportSide ('99 & Newer)	AC110USP4-99, AC110UMP4-99 or AC110ULP4-99	AC110USP4-99, AC110UMP4-99 or AC110ULP4-99	AC110USLP499 or AC110ULLP499
Chevy / GMC SportSide ('98 & Prior)	AC110US, AC110UM or AC110UL	AC110US, AC110UM or AC110UL	AC110USL or AC110ULL
2007 Silverado/Sierra w/o channel system	AC109UMP4-GM	AC109UMP4-GM	AC109ULLP4-GM
Isuzu	AC101, KH1, SK1 or DA102	AC101, KH1, SK1 or DA102	AC105 or AC106
Mazda	AC101, KH1, SK1 or DA102	AC101, KH1, SK1 or DA102	AC105 or AC106
Mitsubishi	AC101, KH1, SK1 or DA102	AC101, KH1, SK1 or DA102	AC105 or AC106
Nissan	AC101, KH1, SK1 or DA102	AC101, KH1, SK1 or DA102	AC105 or AC106
Nissan Frontier 2001	AC101, KH1, SK1 or DA102	AC101, KH1, SK1 or DA102	AC105 or AC106
Nissan Frontier 2005 & newer	AC109USP4-FC, AC109UMP4-FC or AC109ULP4-FC	AC109USP4-FC, AC109UMP4-FC or AC109ULP4-FC	AC109USLP4-FC or AC109ULLP4-FC
Nissan Titan w/Channel System	SK1C, SK2C, SK3C or KH1NT	SK1C, SK2C, SK3C or KH1NT	AC105NT or AC106NT
Nissan Titan w/o Channel System	KH1, SK1 or SK2	KH1, SK1 or SK2	AC105 or AC106
Toyota Tundra (Includes 2000)	AC101, KH1, SK1 or DA102	AC101, KH1, SK1 or DA102	AC105 or AC106
Toyota Tundra 2001 (Factory Bedliner)	KH1-275 or SK1	KH1-275 or SK1	AC106-225
Toyota Tacoma w/Channel System	SK1C, SK2C, SK3C, AC110USP4- TC, AC110UMP4-TC or AC110ULP4	SK1C, SK2C, SK3C, AC110USP4- TC, AC110UMP4-TC or	AC110USL-TC or AC110ULL-TC
Toyota Tacoma (Regular or StepSide)	AC101, KH1, SK1 or DA102	AC101, KH1, SK1 or DA102	AC105 or AC106
Toyota T-100	AC101, KH1, SK1 or DA102	AC101, KH1, SK1 or DA102	AC105 or AC106
Toyota Tundra	AC110ULP4-TU	AC110ULP4-TU	AC110ULLP4-TU

CLAMPS SHOWN ACTUAL SIZE

AC101

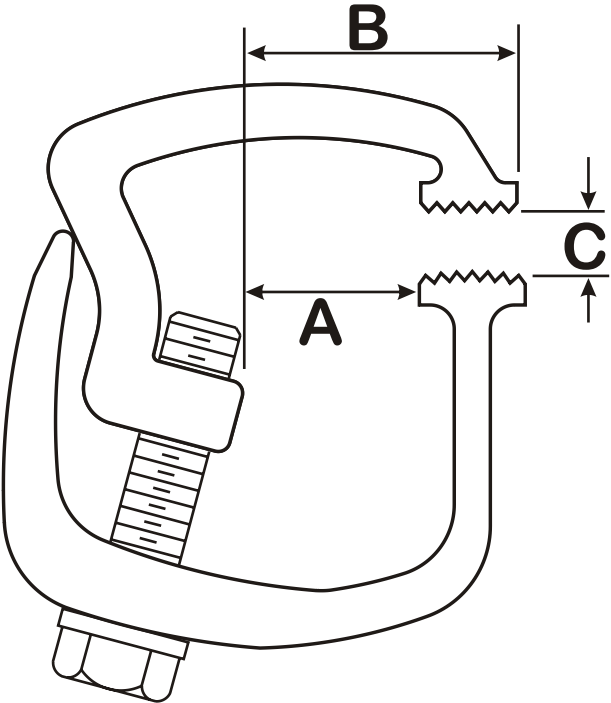

Clamp Width 1-1/4"

- A - 1"
- B - 1-1/2"
- C - 0 to 7/8"

AC102

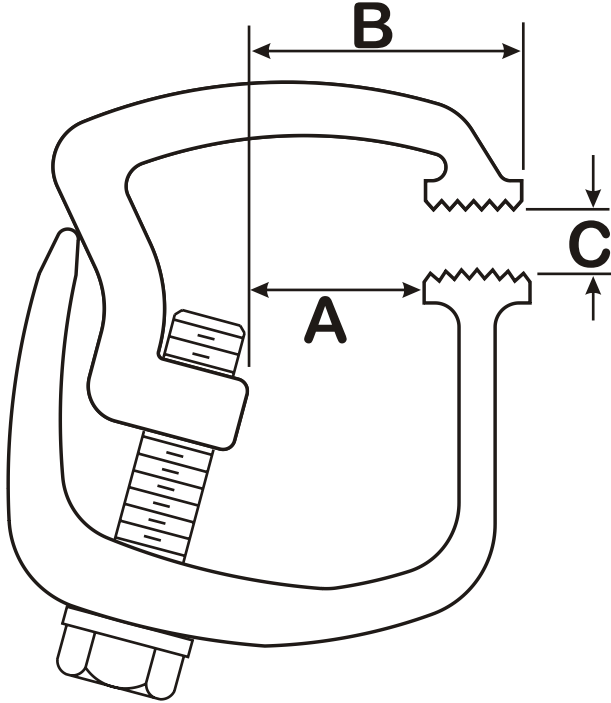

Clamp Width 1"

- A - 1"
- B - 1-1/2"
- C - 0 to 7/8"

CLAMPS SHOWN ACTUAL SIZE

AC103

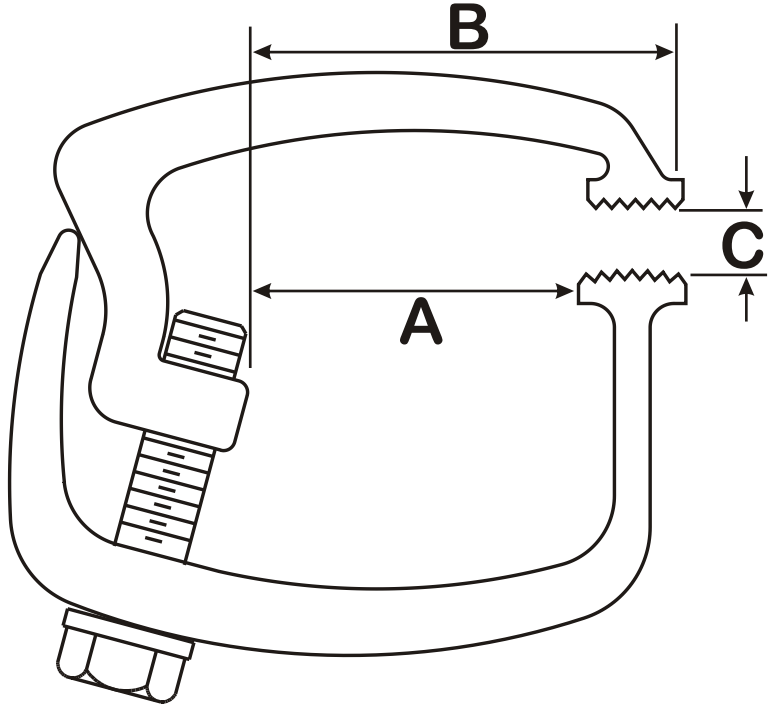

A - 1-3/4"
B - 2-1/4"
C - 0 to 7/8"

AC104

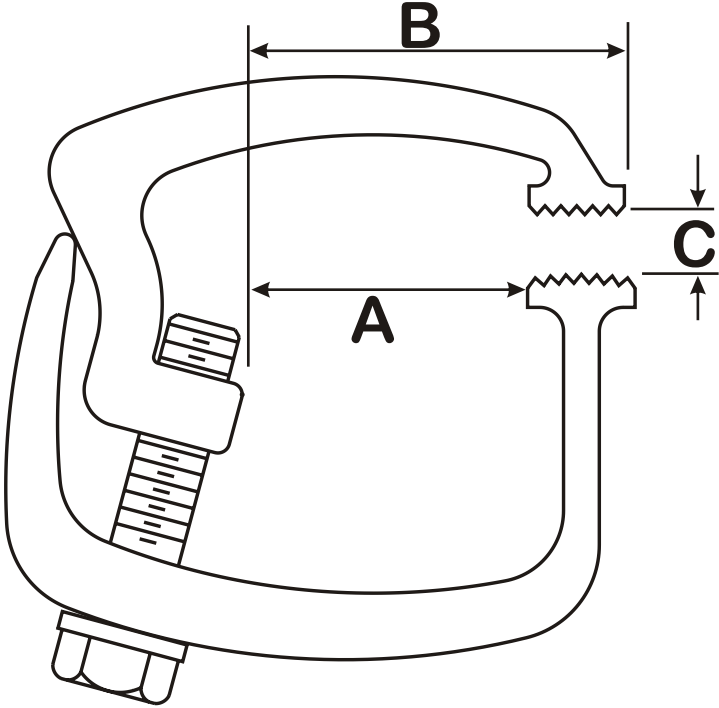

A - 1-1/2"
B - 2"
C - 0 to 7/8"

CLAMPS SHOWN ACTUAL SIZE

AC105

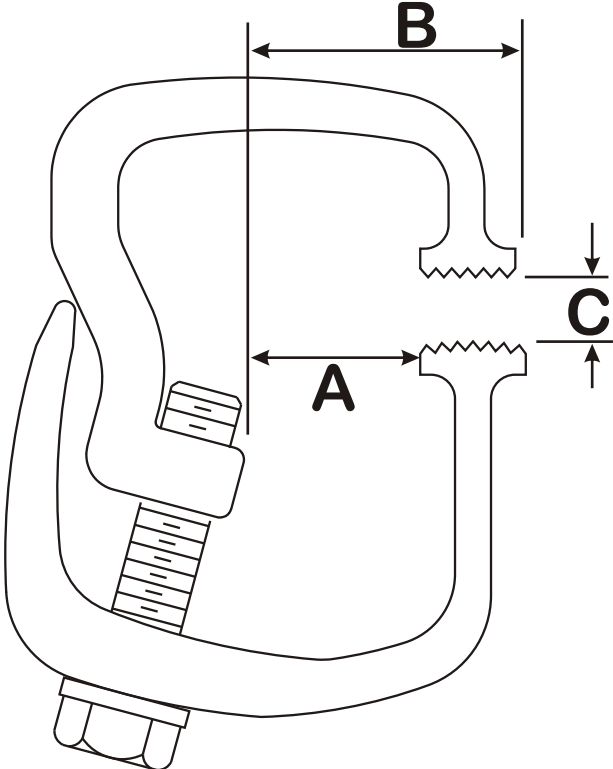

- A - 1"
- B - 1-1/2"
- C - 0 to 7/8"

AC106

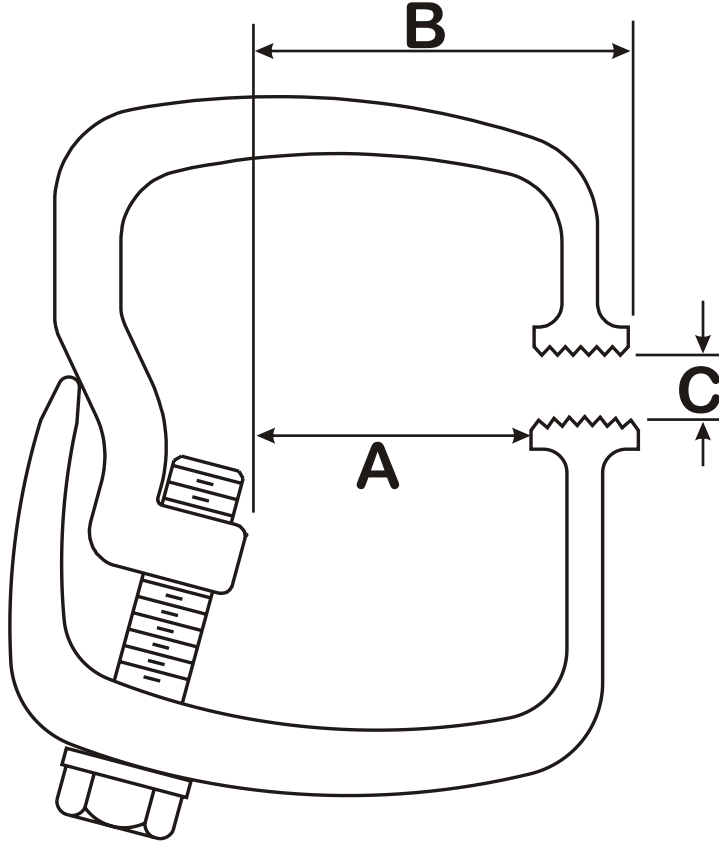

- A - 1-1/2"
- B - 2"
- C - 0 to 7/8"

CLAMPS SHOWN ACTUAL SIZE

AC1031

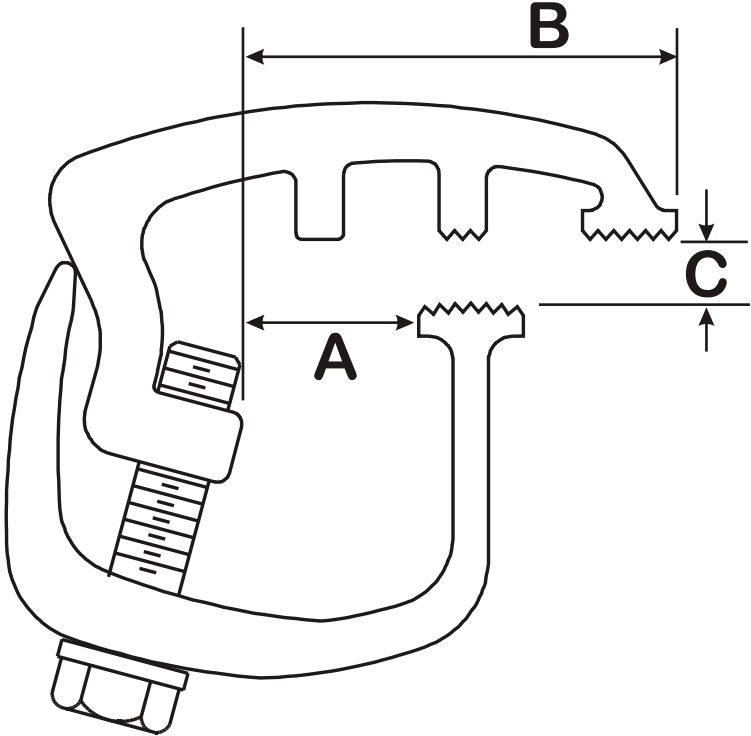

A - 1"
B - 2-1/4"
C - 0 to 7/8"

AC1081
AC108

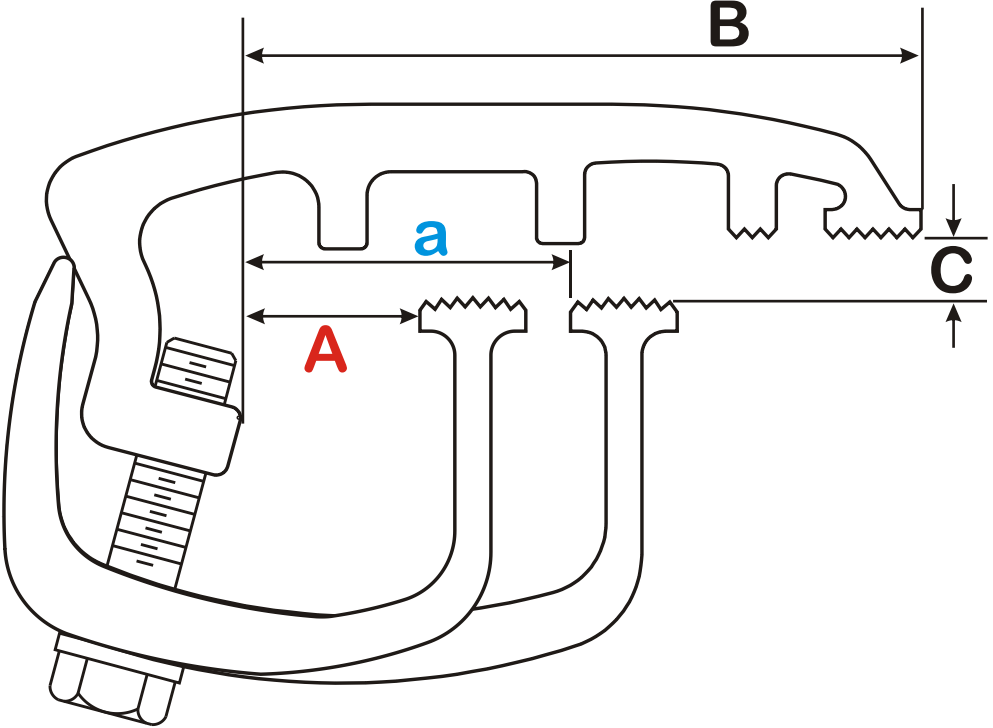

AC1081 **A - 1"**
B - 3-1/4"
C - 0 to 7/8"
AC108 **a - 1-3/4"**
B - 3-1/4"
C - 0 to 7/8"

CLAMPS SHOWN ACTUAL SIZE

AC109US
AC109UM
AC109UL

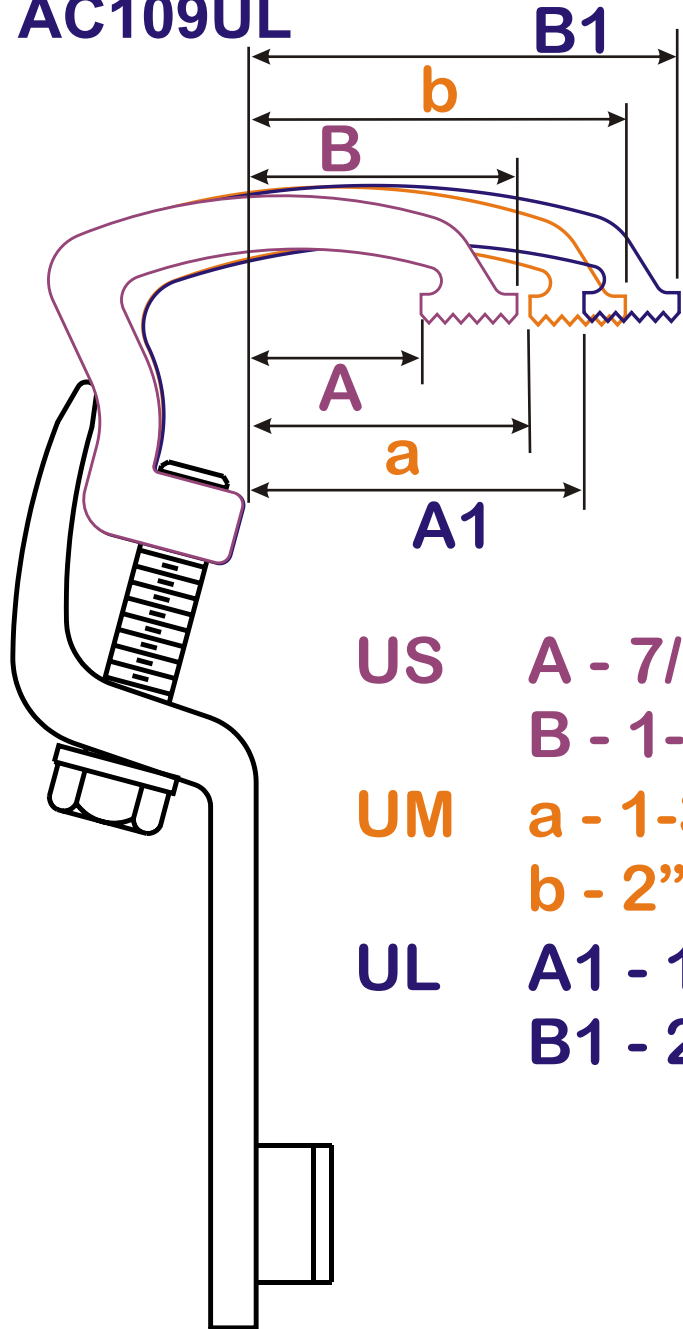

US A - 7/8"
B - 1-1/2"
UM a - 1-3/8"
b - 2"
UL A1 - 1-5/8"
B1 - 2-1/8"

**Ford
FlairSide
Clamps
1996 & Prior**

AC109USL
AC109ULL

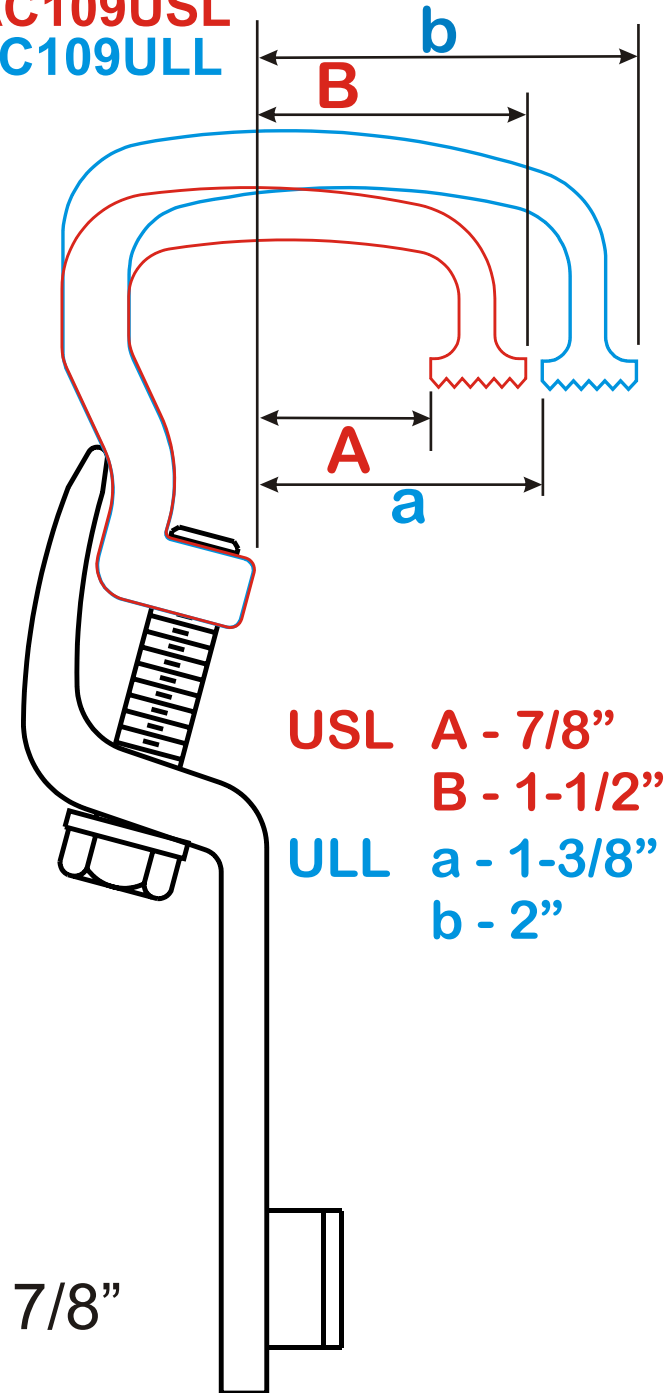

USL A - 7/8"
B - 1-1/2"
ULL a - 1-3/8"
b - 2"

Clamping Range: 7/8"

CLAMPS SHOWN ACTUAL SIZE

AC109US
AC109UM
AC109UL

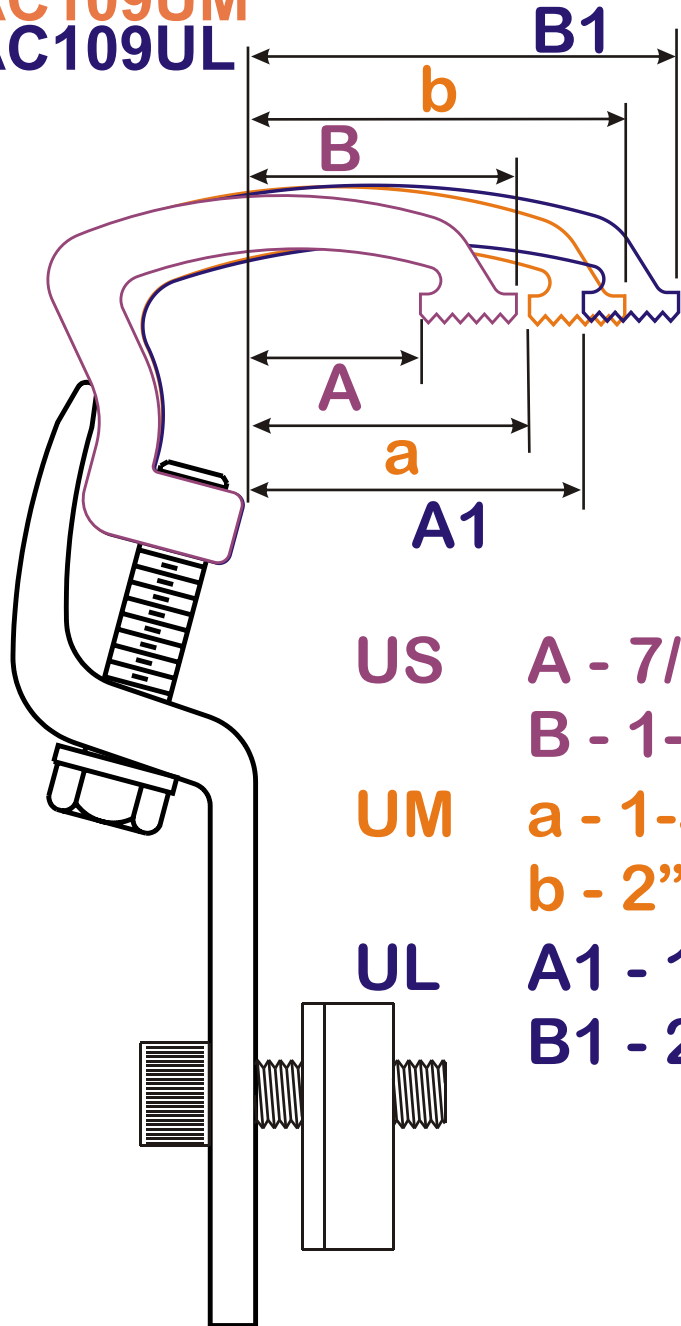

US A - 7/8"
B - 1-1/2"
UM a - 1-3/8"
b - 2"
UL A1 - 1-5/8"
B1 - 2-1/8"

**Nissan
Frontier
Clamps**

AC109USL
AC109ULL

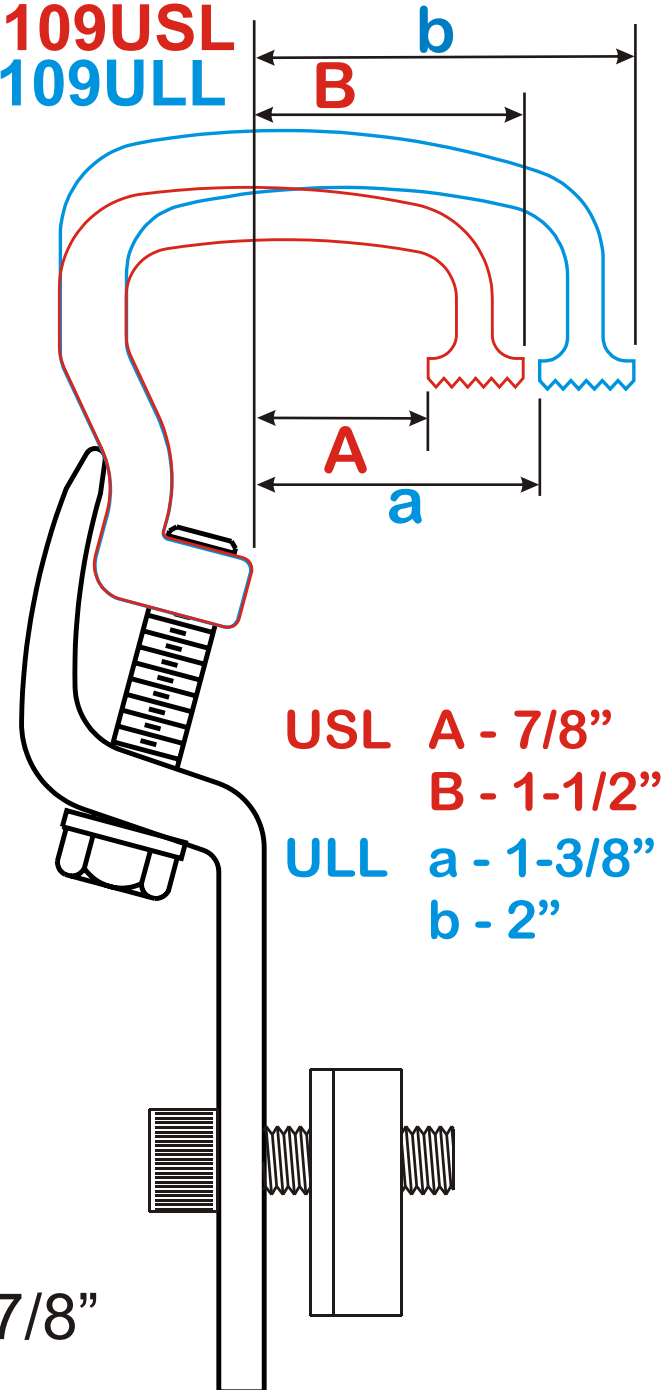

USL A - 7/8"
B - 1-1/2"
ULL a - 1-3/8"
b - 2"

Clamping Range: 7/8"

CLAMPS SHOWN ACTUAL SIZE

AC110US
AC110UM
AC110UL

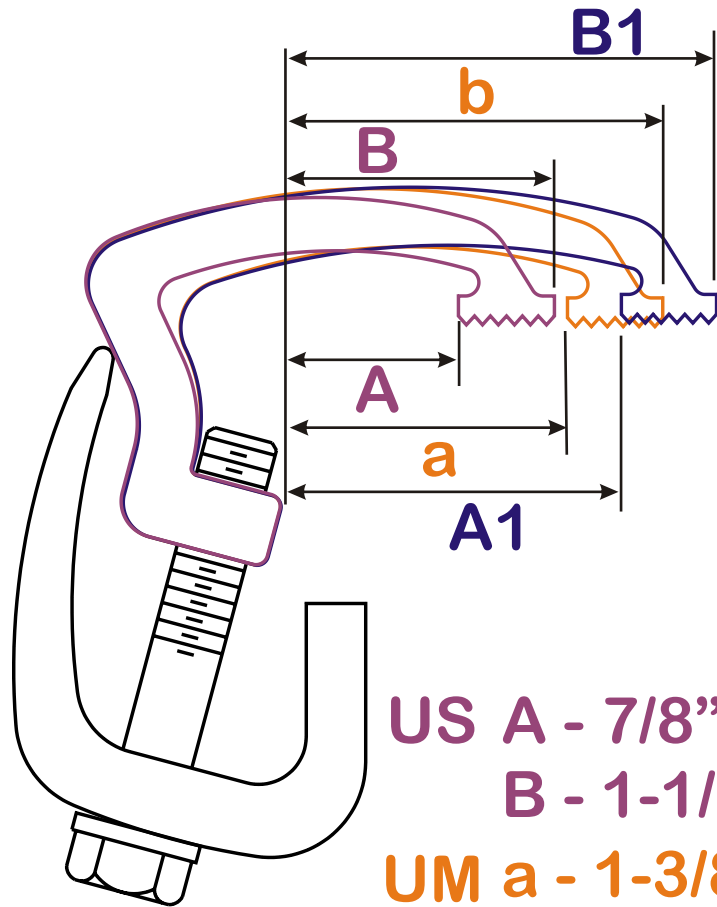

US A - 7/8"
B - 1-1/2"
UM a - 1-3/8"
b - 2"
UL A1 - 1-5/8"
B1 - 2-1/8"

Chevy
StepSide
Clamps
1998
&
Prior

AC110USL
AC110ULL

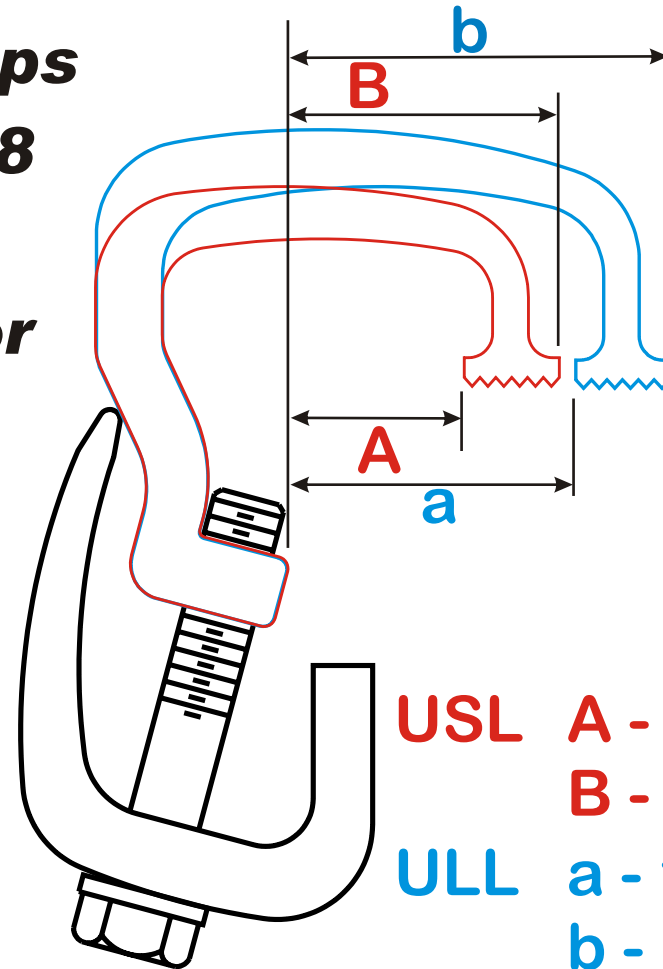

USL A - 7/8"
B - 1-1/2"
ULL a - 1-3/8"
b - 2"

Clamping Range: 7/8"

CLAMPS SHOWN ACTUAL SIZE

AC110US-99
AC110UM-99
AC110UL-99

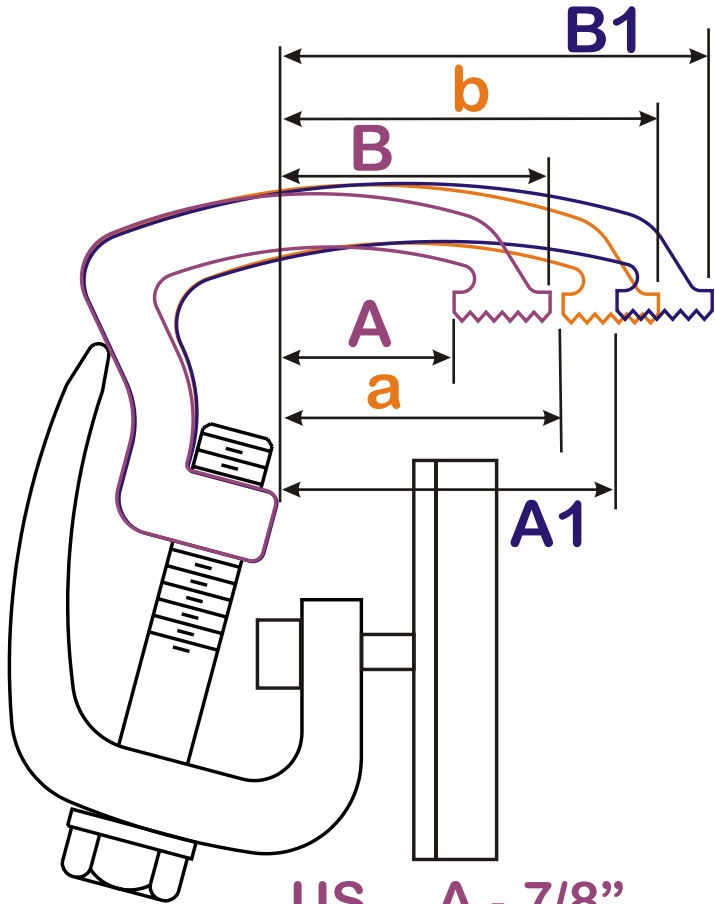

US A - 7/8"
B - 1-1/2"
UM a - 1-3/8"
b - 2"
UL A1 - 1-5/8"
B1 - 2-1/8"

Chevy
StepSide
Clamps
1999
&
Newer

AC110USL-99
AC110ULL-99

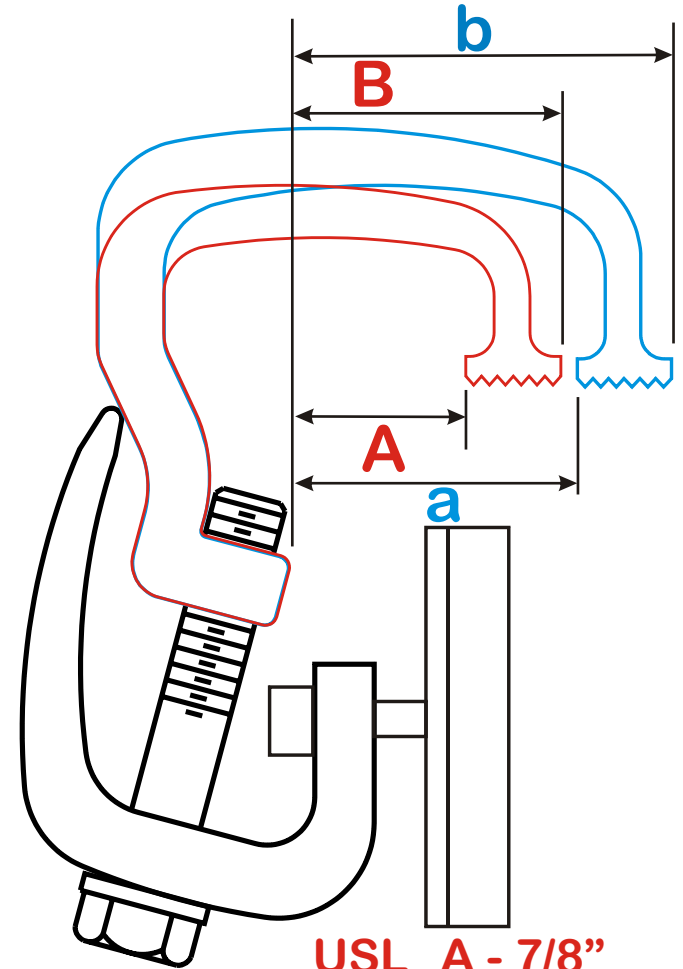

USL A - 7/8"
B - 1-1/2"
ULL a - 1-3/8"
b - 2"

Clamping Range: 7/8"

CLAMPS SHOWN ACTUAL SIZE

AC110US-TC
AC110UM-TC
AC110UL-TC

**Toyota
Tacoma
Clamps
2005
&
Newer**

AC110USL-TC
AC110ULL-TC

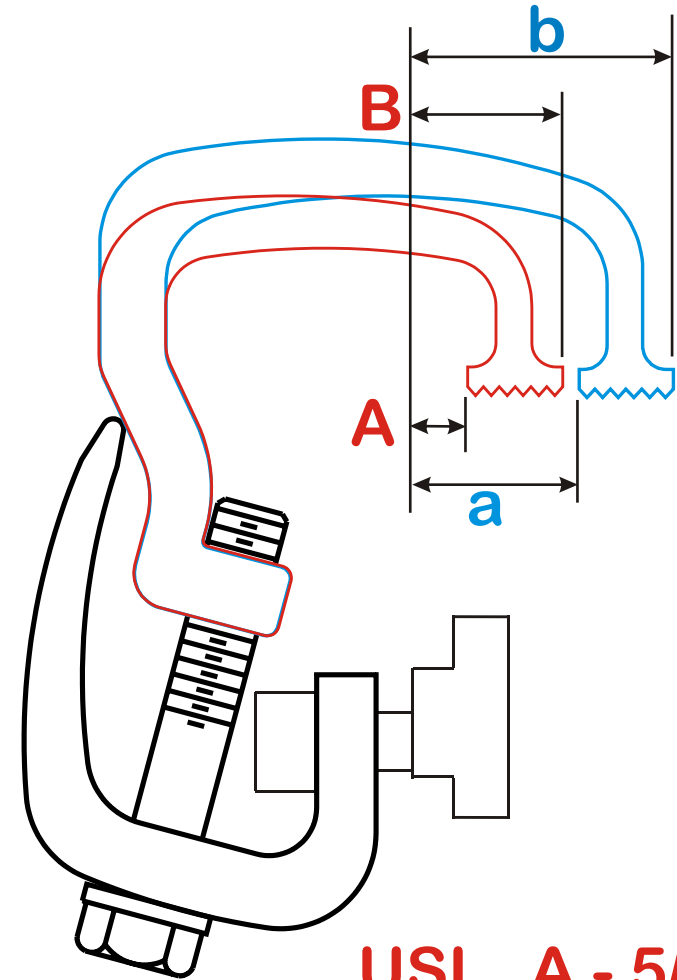
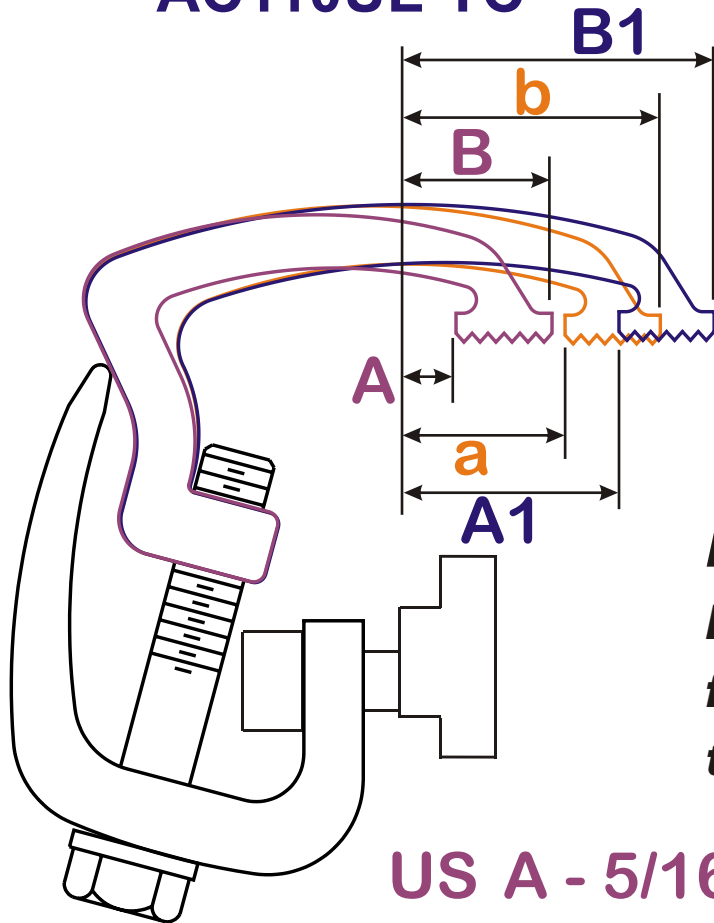

Note:
*Dimensions
from inside
truck bed rail.*

US A - 5/16"

B - 15/16"

UM a - 7/8"

b - 1-3/8"

UL A1 - 1-1/8"

B1 - 1-5/8"

Clamping Range: 7/8"

USL A - 5/16"

B - 15/16"

ULL a - 7/8"

b - 1-3/8"

CLAMPS SHOWN ACTUAL SIZE

AC110UM-TU
AC110UL-TU

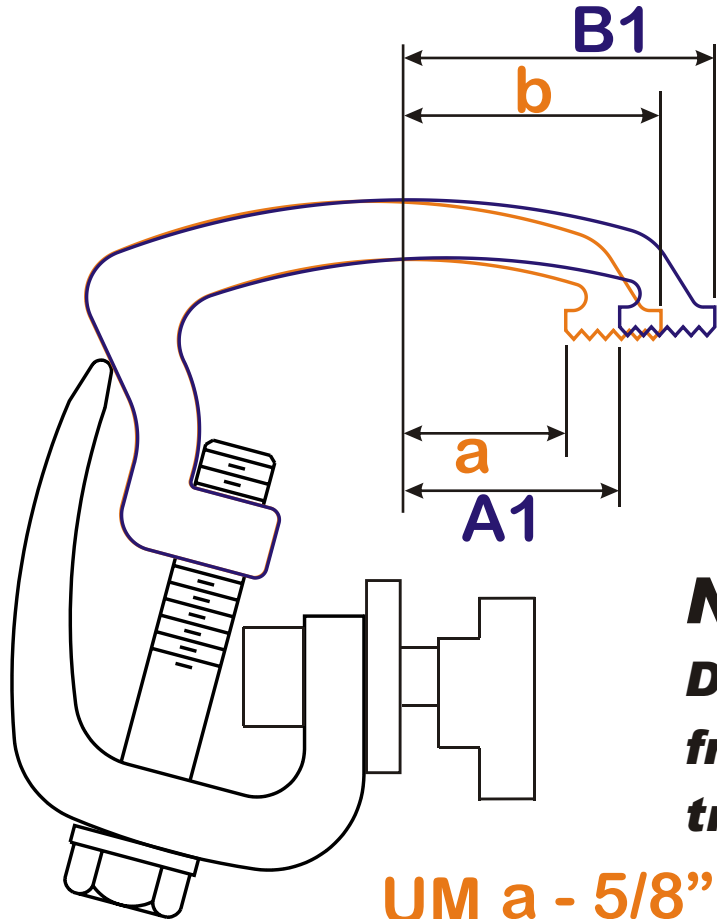

**Toyota
Tundra
Clamps
2007
&
Newer**

Note:
**Dimensions
from inside
truck bed rail.**

UM a - 5/8"
b - 1-1/8"
UL A1 - 7/8"
B1 - 1-3/8"

Clamping Range: 7/8"

AC110ULL-TU

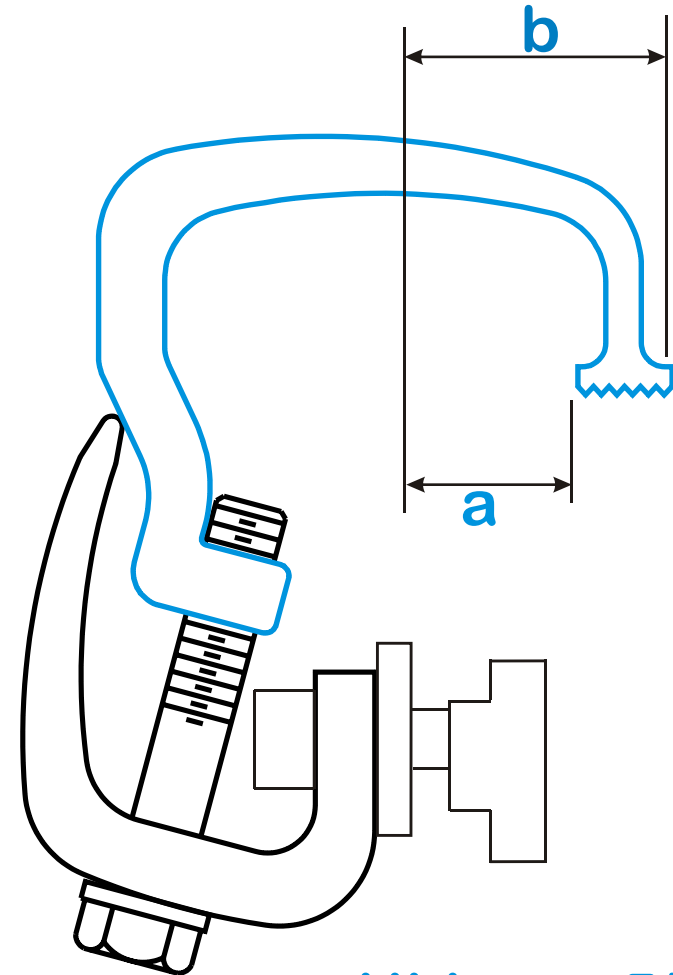

ULL a - 5/8"
b - 1-1/8"

CLAMPS SHOWN ACTUAL SIZE

AC111US
AC111UM
AC111UL

Ford
Explorer
Sport Trac
Clamps

AC111USL
AC111ULL

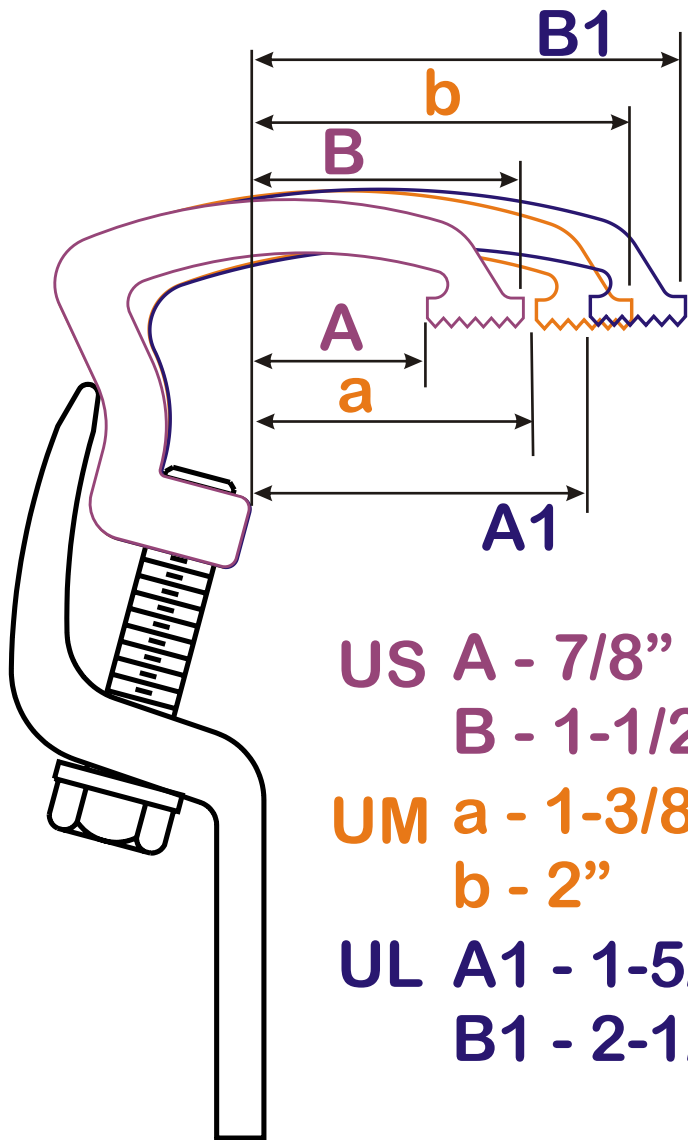

US A - 7/8"
B - 1-1/2"
UM a - 1-3/8"
b - 2"
UL A1 - 1-5/8"
B1 - 2-1/8"

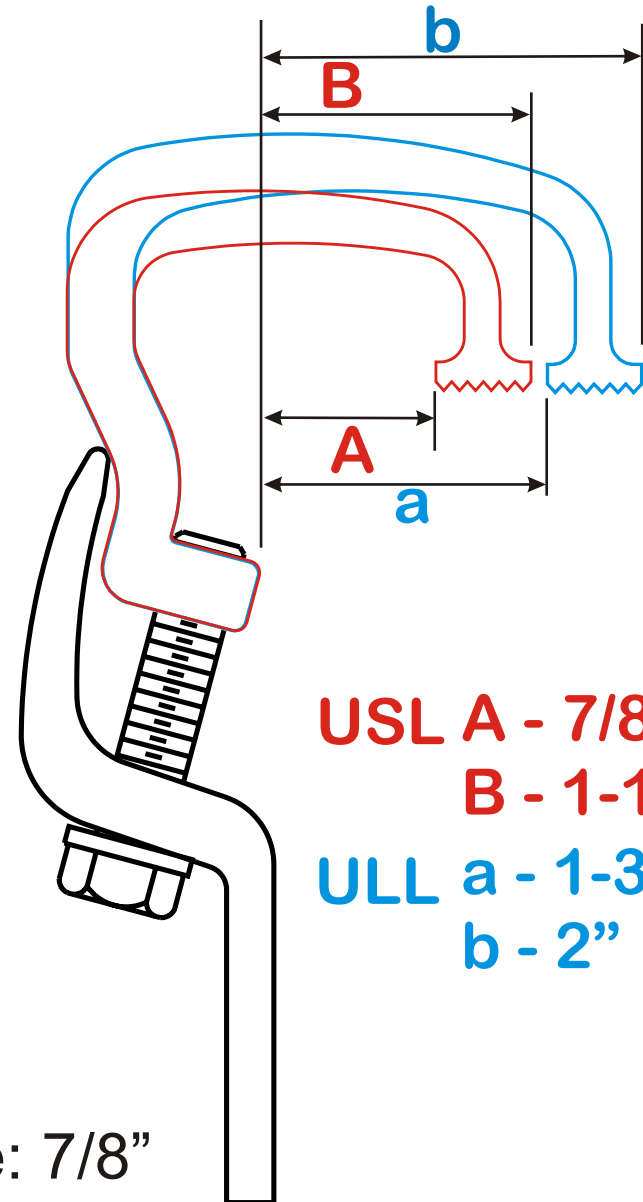

USL A - 7/8"
B - 1-1/2"
ULL a - 1-3/8"
b - 2"

Clamping Range: 7/8"

CLAMPS SHOWN ACTUAL SIZE

AC1043

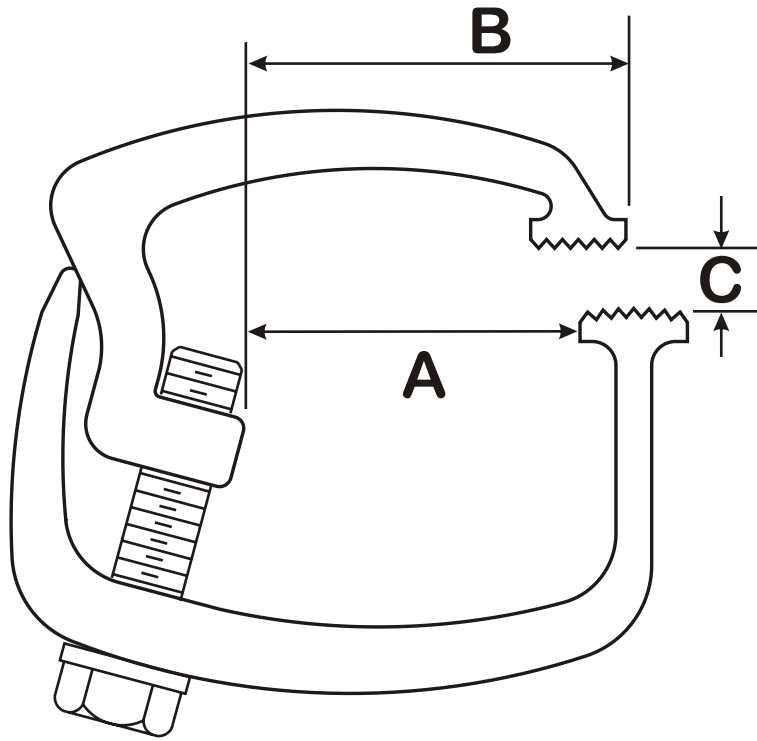

A - 1-3/4"

B - 2"

C - 0 to 7/8"

KH1

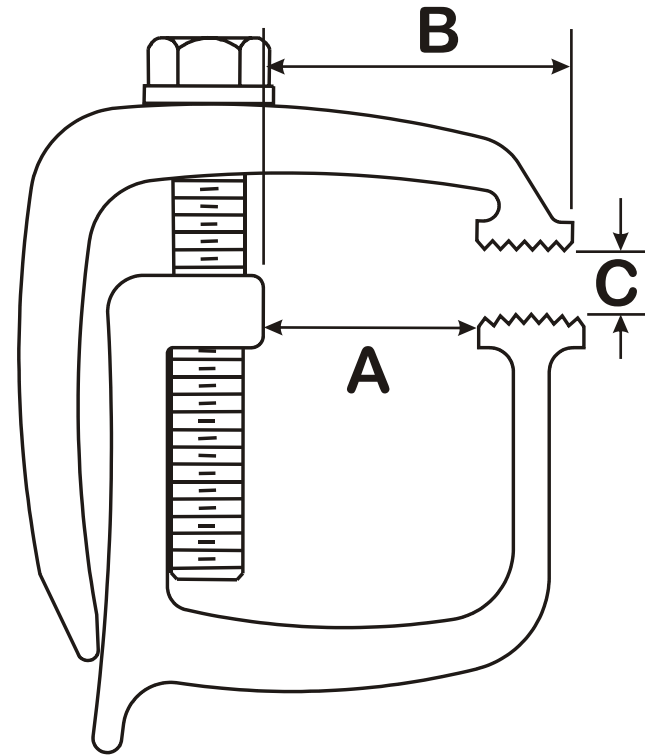

A - 1-1/8"

B - 1-5/8"

C - 0 to 1-3/8"

CLAMPS SHOWN ACTUAL SIZE

SK1

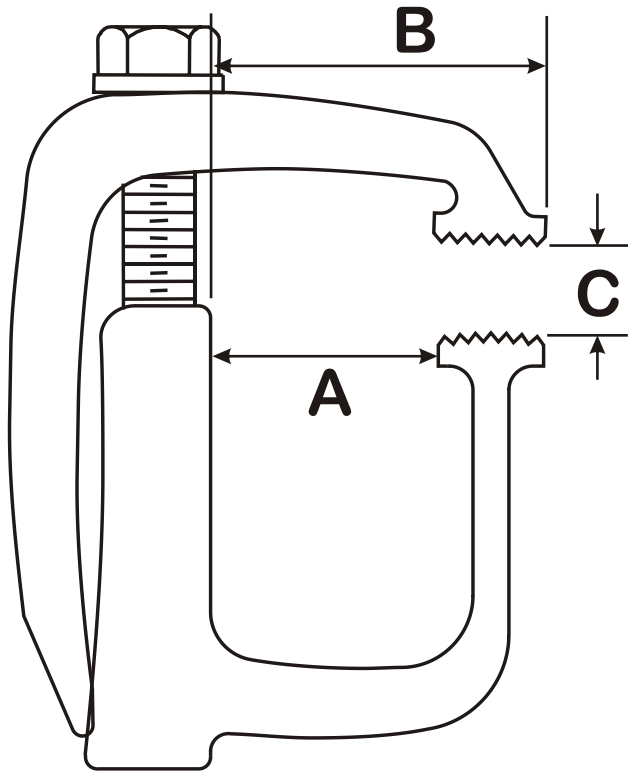

A - 1-3/16"
B - 1-3/4"
C - 0 to 1-1/2"

SK2S
SK2

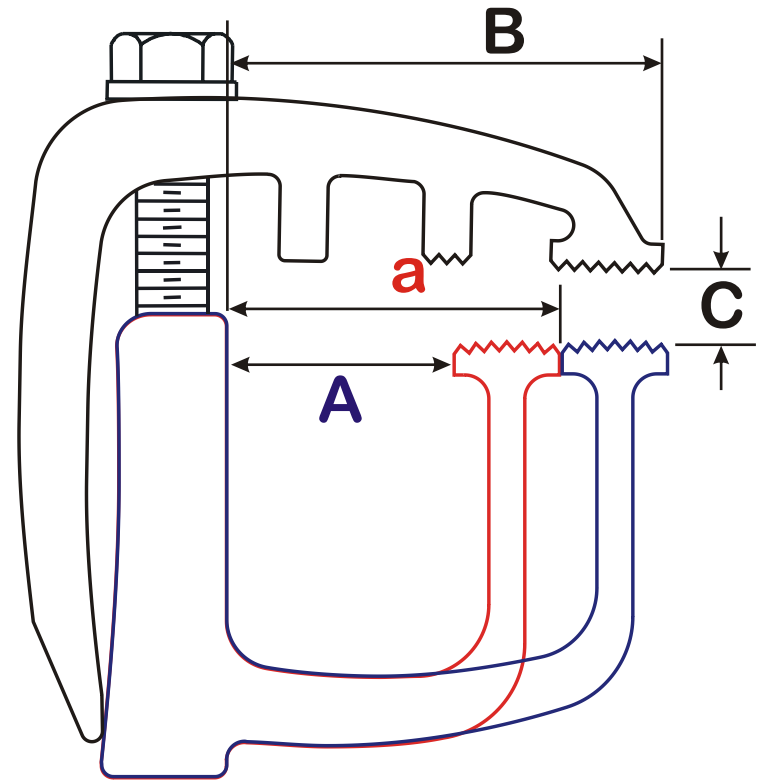

SK2 A - 1-3/4"
SK2S a - 1-3/16"
B - 2-5/16"
C - 0 to 1-1/2"

CLAMPS SHOWN ACTUAL SIZE

SKC1
SKC2
SKC3

*Toyota Tacoma
& Nissan Titan
Clamps
2005
& Newer*

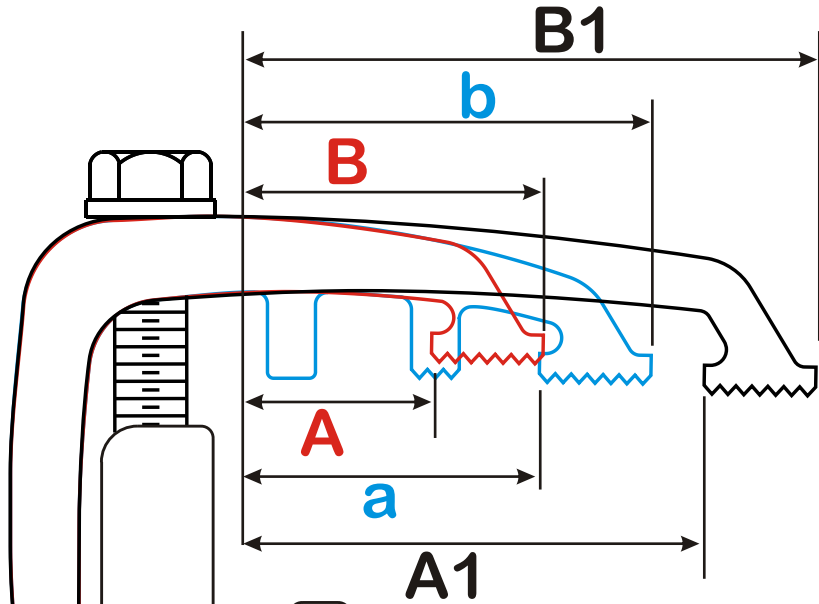

SKC1 A - 15/16"
B - 1-1/2"

SKC2 a - 1-1/2"
b - 2-1/16"

SKC3 A1 - 2-5/16"
B1 - 2-7/8"

SK10
SK20
SK30

*Ford
F Series
Clamps
2004
& Newer*

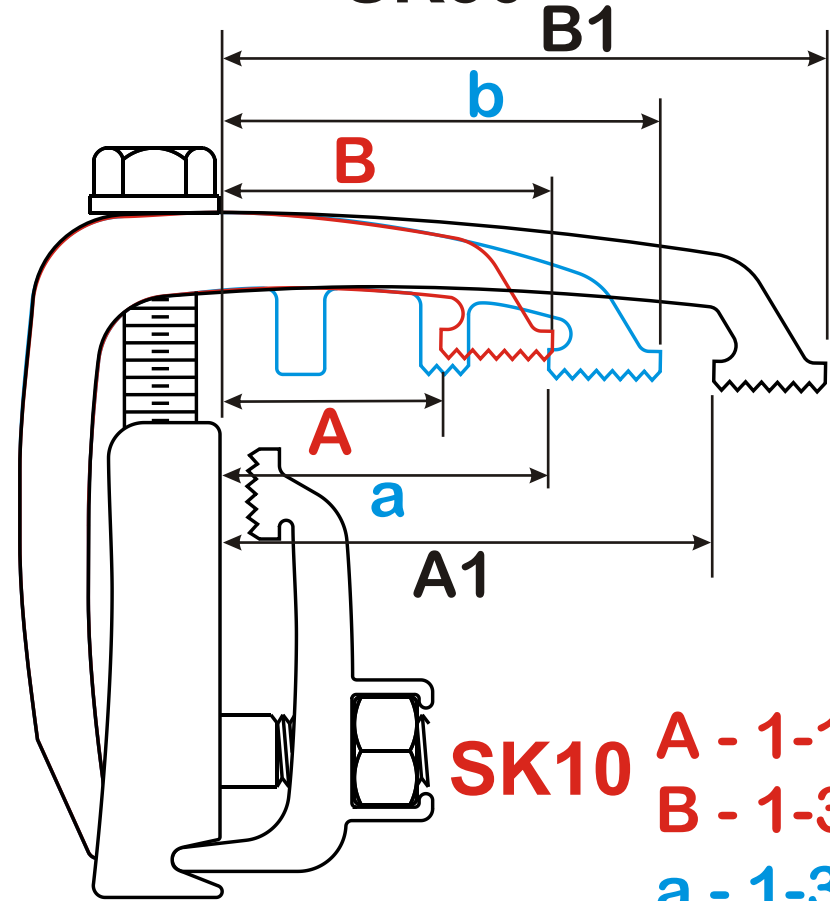

SK10 A - 1-1/8"
B - 1-3/4"

SK20 a - 1-3/4"
b - 2-5/16"

SK30 A1 - 2-9/16"
B1 - 3-3/16"

Clamping
Range: 1-3/8"