

Torque Specifications



Plug Thread & Seat	Cast Iron Heads		Aluminum Heads	
	SAE	Metric	SAE	Metric
10mm Gasket	7-11 ft lb	10-15 nm	7-11 ft lb	10-15 nm
12mm Gasket	11-19 ft lb	15-25 nm	11-19 ft lb	15-25 nm
14mm Gasket	16-29 ft lb	35-40 nm	15-22 ft lb	20-30 nm
18mm Gasket	32-38 ft lb	43-52 nm	28-34 ft lb	38-46 nm
14mm Tapered	7-15 ft lb	9-20 nm	7-15 ft lb	9-20 nm
18mm Tapered	15-20 ft lb	20-27 nm	15-20 ft lb	20-27 nm

NOTE: Spark plugs should be installed with clean and dry threads to avoid over-torquing. This can distort the metal plug shell, which often results in engine damage.

Gasket Seat



10mm Gasket Seat

Finger Tight Plug

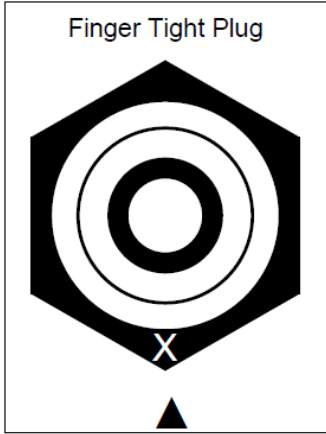

12mm Gasket Seat

1/4 Turn

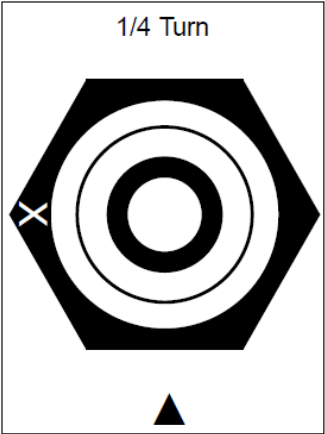

3/8 Turn

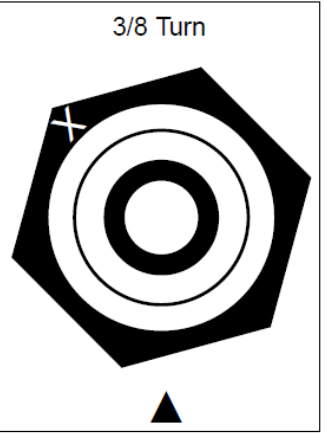

Tight to:

14 and 18mm tapered seat tighten 1/16 turn

14 and 18mm gasket seat tighten 1/2 turn

12mm gasket seat tighten 3/8

10mm gasket seat tighten 1/4 turn, *past finger tight.*

14 & 18mm Gasket Seat

1/2 Turn

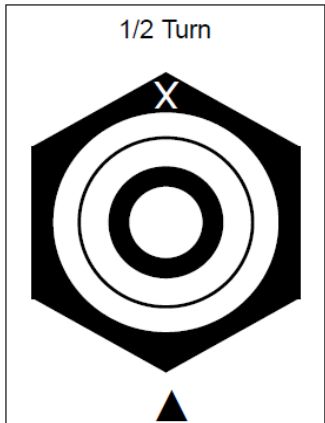

14 & 18mm Tapered Seat

1/16 Turn

