



# INSTALLATION INSTRUCTIONS ELECTRIC BOOST/VAC GAUGE

Part Number 77060060  
77060061



Read instruction thoroughly to verify all required parts are there before installing this product.

### Contents:

#### For Boost/Vac Gauge

- 1 - Wiring Harness – 8 ft.
- 1 - Nylon Tubing – 10 ft.
- 1 – MAP Sensor

- 1 - T-Fitting  $\frac{3}{16}$ " x  $\frac{1}{8}$ " x  $\frac{3}{16}$ " NPT
- 1 - Rubber Fitting -  $\frac{1}{8}$ " x  $\frac{7}{32}$ "
- 2 - Aluminum Thumb Nuts
- 1 - Rubber Grommet

- 1 - Mounting Bracket
- 2 - Lock Washers
- 1 - Compression Adapter

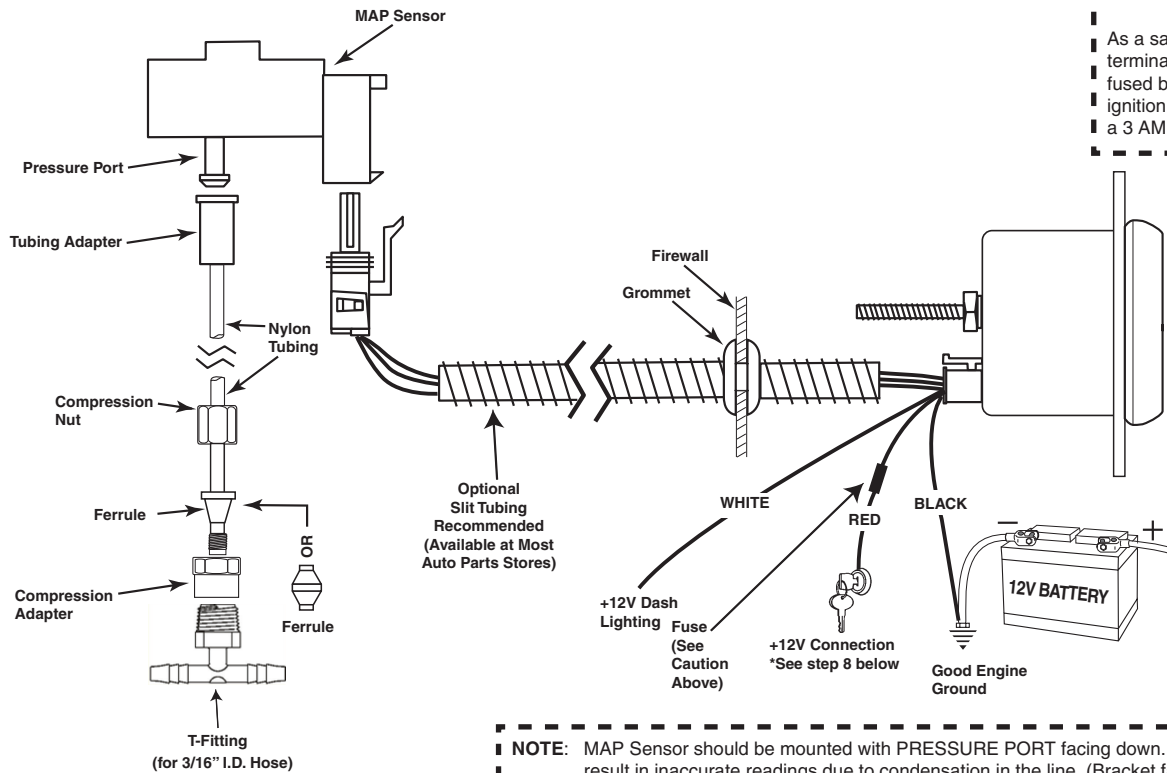

**CAUTION!**  
As a safety precaution, the +12V terminal of this product should be fused before connecting to the 12V ignition switch. We recommend using a 3 AMP automotive type fuse.

**NOTE:** MAP Sensor should be mounted with PRESSURE PORT facing down. Failure to do so could result in inaccurate readings due to condensation in the line. (Bracket fabrication may be required.)

A T-fitting for 1/4" I.D. hose is available as model # 3276.

## Installation

1. Check that you have all parts required for installation, and the engine is cool.
2. Disconnect the negative (-) battery cable.
3. Gauge mounts in a  $2\frac{1}{16}$ " hole. Use supplied brackets and nuts to secure gauge to dash.
4. Drill 1" diameter hole where wires pass through sheet metal (such as firewall) and install rubber grommet provided. (Grommet will require slit.)
5. Securely mount the MAP sensor to the firewall or inner fender with pressure port facing down. (Bracket fabrication may be required.)
6. Install T-Fitting in a manifold vacuum hose. Attach one end of the nylon tubing to the T-Fitting using the compression adapter. Connect the other end of the nylon tubing to the MAP sensor with the tubing adapter. A T-fitting for 1/4" I.D. hose is available as Auto Meter model # 3276.
7. Connect the white wire to dash lighting or switchable 12v light source.
8. Connect the red power wire to a switched +12 volt source that **maintains power during engine cranking**. Most vehicles break the electrical connection to accessories while the engine is being started. If the boost gauge is connected to one of these circuits, the auto zero function will not work properly and inaccurate readings will result. To determine whether a switched source maintains power during starting, look for electrical accessories in the vehicle **that remain on while the engine is being started**. Connect the red power wire to the same circuit that powers one of these accessories. The connection can be tested by turning the key switch from off to on, the pointer will move backward to the stop pin and then move to zero. Once the pointer has reached zero, start the engine. If the pointer reads vacuum without returning to the stop pin, a suitable connection has been found. If the pointer moves to the stop pin and then reads vacuum, another power circuit must be found.

## Power-Up

The pointer will move backward to the stop pin and then move to the zero box. This procedure is an auto-calibration function and is performed on every power-up. While this test is being performed, the gauge may make a clicking sound. This is normal. Electronic Boost/Vac gauges are equipped with an auto zero function used to compensate for operation at varying altitudes. This function takes a pressure reading during the time that the key switch "flies through" from the ON position to the START position. The reading represents 0 pressure and is used to set the zero point on the gauge each time the engine is started.