

INSTALLATION INSTRUCTIONS FULL SWEEP ELECTRIC VOLT METER

2650-1135-00



Installation

1. Check that you have all parts required for installation.
2. Disconnect the negative (-) battery cable.
3. Gauge mounts in a 2 $\frac{1}{16}$ " hole. Use supplied brackets and nuts to secure to dash.
4. Attach black wire from harness to good engine ground.
5. Attach red wire from harness to +12V terminal on ignition switch or other +12V power source. Use a switched power source.
6. Attach white wire to dash lighting or switchable +12V light source.
7. Reconnect negative (-) battery cable.

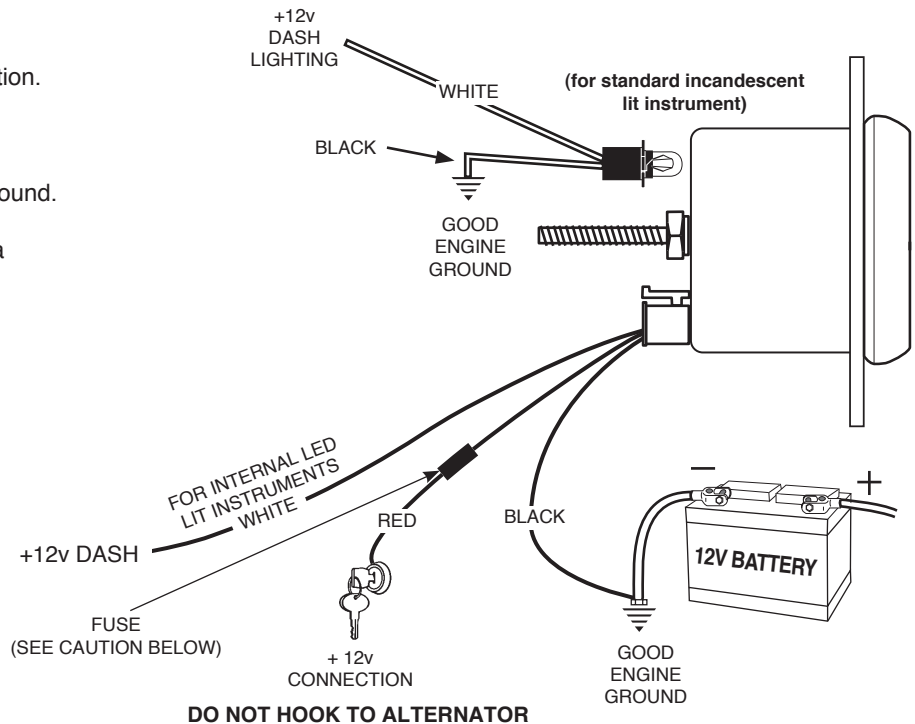

CAUTION!

As a safety precaution, the +12V terminal of this product should be fused before connecting to the 12V ignition switch. We recommend using a 1 Amp, 3AG fast-acting type cartridge fuse (Littlefuse® # 312 001 or an equivalent).

Power-Up

The pointer will move backward to the stop pin and then display the correct voltage. This procedure is an auto-calibration function and is performed on every power-up. While this test is being performed, the gauge may make a clicking sound. This is normal.

For model with warning light and peak recall

Warning Indicator

To adjust the warning set point, momentarily press and release the WARN button. The warning light will begin to flash and the pointer will move to the previous set point signifying that warning set mode has been selected. Once in set mode, press the WARN button to move the pointer down, or press the PEAK button to move the pointer up. Warning set points can only be set in the voltage range. Three seconds after the last button press, the warning light will stop blinking and the pointer will return to the current voltage reading. The warning set point is retained when power is removed from the gauge.

Peak Recall

Press and hold the PEAK button to recall the highest voltage reading since the memory was last cleared. To clear the memory, press and hold the PEAK button, and while still holding the PEAK button, press the WARN button. The pointer will move to Stop Peg to indicate that the memory has been cleared. Release the PEAK and WARN buttons to resume normal operation. The peak recall point is retained when power is removed from the gauge.