

INSTALLATION INSTRUCTIONS

DIGITAL TACH/SPEEDO COMBO



Innovative E•Z View™ Display System

- Maximizes readability
- Minimizes distracting High Speed digit changes

General Information

This instrument utilizes a single LCD to display odometer and two trip odometer mileages. Press the Trip button on the dial window to cycle between odometer, Trip 1, and Trip 2 displays on the LCD. Pressing and holding the Trip button for more than 2 seconds while viewing either Trip display will reset the trip currently being displayed. The odometer cannot be reset.

NOTE: The odometer on the speedometer portion of this instrument will show some mileage less than 5 miles (8km). This is a result of factory testing to ensure optimum quality.

TIP: Auto Meter always recommends performing the calibration process for best speedometer accuracy.

Speedometer Senders:

The electronic speedometer in this instrument is designed to operate with an electrical speed sender. The speed sender signal range must be between 500 and 400,000 pulses/mile (310 and 248,500 pulses/km). Any speed sender or electronic module that meets the following two conditions can be used:

1. Pulse rate generated is proportional to vehicle speed.
2. Output voltage within the ranges listed below:
 - a. Hall effect sender, 3 wire (5 to 16V)
 - b. Sine wave generator, 2-wire (1.4 VAC min.)
 - c. 5v Square Wave (CMOS)

Recommended – Auto Meter Hall effect sender, 3 wire, 16 pulses/revolution
5291 Standard 7/8" – 18 Thread
5292 Ford, plug in

Installation Tips

1. A 12 V power source **MUST** be used to power this speedometer. A 12V motorcycle battery is a good alternative for cars without batteries. A battery with minimum 5 amp hour rating is recommended.
2. Wherever possible, solder wire connections and avoid crimp-type connectors. This will minimize loose connections that could cause problems later.
3. Make sure you have a good ground to engine and battery negative terminal.
4. Wire installations should be neat and tied down to prevent tugging and fraying of wires at connections.

Wiring

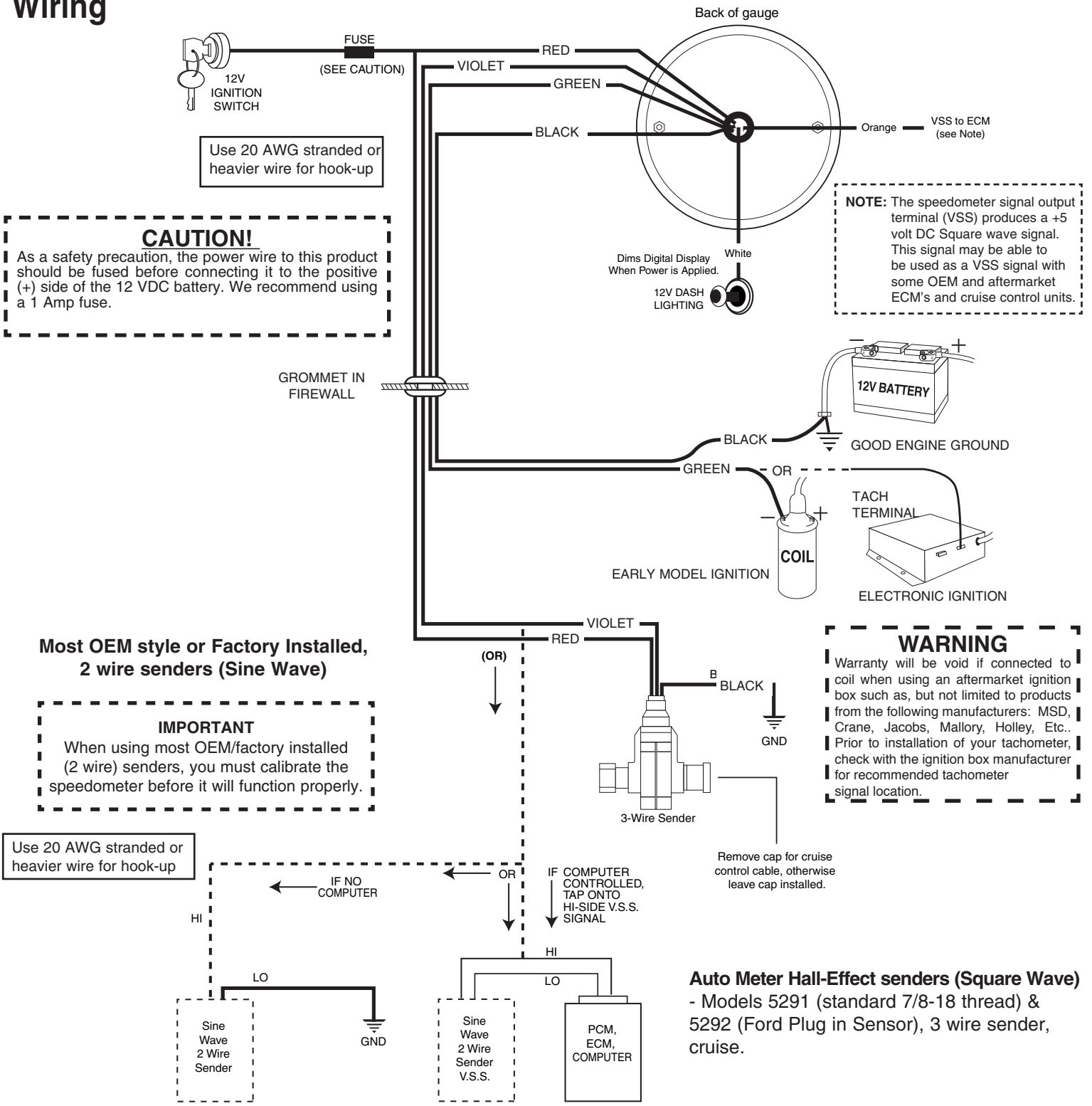

Mounting

1. Mount this instrument in a 3 3/8" dia. hole.
2. Cut a 3/8" dia. hole in the firewall for the speedometer wires. Place a rubber grommet in the hole and route the wires through the grommet to the engine compartment.
3. Connect the speedometer wires as shown in the wiring sections.
4. Secure the speedometer to the dashboard using the provided bracket and hardware.

3 3/8" Models

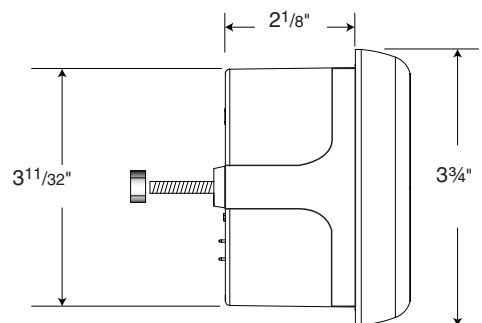

Operation

When power is first applied to the gauge, the tach display will show “8888” and the speed display will show “888”. Then it enters normal operation mode, the speed display will show “0” and the odometer will display the odometer or trip miles, depending on the state of the odometer (total miles or trip) when it was last turned off. The tach display will show “000” if the engine is off, or the idle RPM if the engine is running.

Testing

Once the instrument is mounted and wired into the vehicle (see preceding page), the instrument should be tested to verify that the electrical connections are working properly. First, watch the instrument’s display as power is applied with the key in the accessory position. The speed display will show “888” and the tach display will show “8888”. Then the tach display will show “000”, the speed display will show “0”, and the odometer will show the current miles. This action verifies that power is properly connected to the instrument. Start engine. The Tach display will show the idle RPM. The vehicle should be driven some distance to verify the Vehicle’s Speed Sender (VSS) is connected properly and that the display indicates speed. If the display does not indicate speed, verify that the VSS is connected properly and that calibration has been performed.

Calibration (Electronic Speedometer calibration made easy!)

To calibrate your electronic speedometer:

- 1) With the power off, push and hold the trip button. While holding the button, start the vehicle and continue to hold the button until the display shows “PrE”. You may now release the button.
- 2) Drive to the beginning of a pre-marked 2 mile (2 km if in km/h mode) distance and come to a stop. It does not matter how far away it is to get to this pre-marked 2 mile distance. DO NOT SHUT THE ENGINE OFF. Push and release the trip button. The display will show “rdy”.
- 3) Drive the 2 mile distance. The display will show “CAL” no matter what speed you drive. It will be normal to see the LCD display counting rapidly as it is receiving a speed signal. If you have to stop during the calibration, that is o.k. The speedometer will simply stop counting pulses during this time.
- 4) At the end of the 2 mile distance, come to a complete stop and push and release the trip button. The display will show “End”, the odometer will show the calibrated PPM, and the calibration is stored. Then the display will show “0” and the odometer will show miles. You are now finished.

Remember the accuracy of your 2 mile distance will directly affect the accuracy of your speedometer.

The following list contains factors that can affect speedometer accuracy and how to minimize them during calibration.

1. Tire diameter increases slightly as vehicle speed increases. To minimize this error drive at an average speed of 45 MPH (175 KPH) during calibration.
2. Tire diameter increases slightly as tire air pressure increases. To minimize this error, check the vehicle’s tires to ensure correct air pressure.
3. Tire diameter changes with vehicle load. Minimize this error by having an average load in the vehicle during calibration.
4. Minimize tire slippage error by not breaking traction during calibration.

Note: Always recalibrate your speedometer after any tire size or differential ratio change.

Configuration

The tachometer is configured at the factory for 4 PPR. (8 CYL)

To change the PPR, follow the steps below:

1. With no power applied to the tach, press and hold the TRIP button.
2. While holding the TRIP button, apply power to the tach by turning the ignition switch to the “Accessory” or “On” position. Do not start the engine! Release the TRIP button immediately after power is applied. The display will show 0.5.

3. The display will change every 1.25 seconds to 1.0, then 1.5, 2.0, 2.5, 3.0, 3.5, 4.0, 4.5, 5.0, 5.5, 6.0, and back to 0.5. See the table below to find the display reading that corresponds to the desired PPR.
4. When the display indicates the desired PPR, press and hold the TRIP button for 1 second, then release. This will permanently store the settings and exit Configuration mode.

ENGINE	Most 2 cyl.	Most 4 cyl.	Most 6 cyl.	Most 8 cyl.
PPR	1	2	3	4

MODE

The MODE button allows the user to select between MPH and km/h (kilometers per hour) at any time, even while the vehicle is in motion. When in MPH mode, the arrow on the lower left side of the LCD odometer will be on. When in km/h mode, the arrow on the lower right side of the LCD odometer will be on. Changing modes will change the speed on the LCD display, as well as the accumulated odometer and trip values. It is important to note that this affects field calibration. If in MPH mode, field calibration is done by driving two miles. If in km/h mode, field calibration is done by driving two kilometers.