

Preliminary Steps

1. Read instructions thoroughly. The installation of this product requires the expertise of a trained automotive mechanic. Please consult a qualified mechanic if you have not had training in the proper installation of instruments.
2. Determine ideal mounting location. Choose a location that will not obstruct visibility or impair driving. Consult your vehicle's repair manual to locate: A) water temperature port
B) 12V ignition switch or fuse box
C) oil pressure port
3. Consult your vehicle's manual to determine the best route for tubing to follow. Choose a path free from hazard of moving parts or hot engine components.
4. Assemble tools and parts required for installation.
5. Disconnect negative (-) battery cable. (Wear safety glasses) Do not allow cable to touch battery or any metal. (NOTE: Disconnecting battery ground may require you to re-program your radio station and clock after re-connection).

CAUTION: Some late model vehicles use electronic sensors in their pressure and temperature senders for engine control functions. Before removing the original senders, we recommend that you contact your Auto Dealer to be sure no critical functions will be disrupted.

- With pressure gauges, it is beneficial to add a T-fitting to install your new gauge and to keep the warning light operational. This allows you to monitor the pressure and still have a warning light to indicate emergency conditions.

Important Assembly Procedures To Follow

1. Tighten nuts and lock washer that secure the gauge mounting bracket. Be sure they are not so tight as to bend or distort mounting bracket.
2. Electrical Connections
Install additional wiring and hardware as shown in diagrams to follow. Now tighten the outer nut while holding the inner nut. This is the only correct procedure and must be followed to insure safe electrical connections. This applies to both the gauge and sender connections.
3. Make sure wires are not rubbing against metal or each other.
NOTE: Install gauges when engine is cool.

Snap-On Chrome Bezel

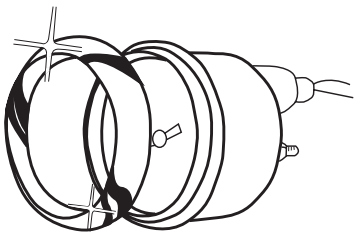

An additional snap-on chrome bezel is provided with this gauge kit to allow for custom styling of gauge. For light replacement use Auto gage replacement bulb No. 2389

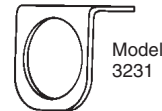

Mounting Options

One, two and three-hole black panels are available for mounting gauges under dash.

Temperature MODELS 2313 & 2314

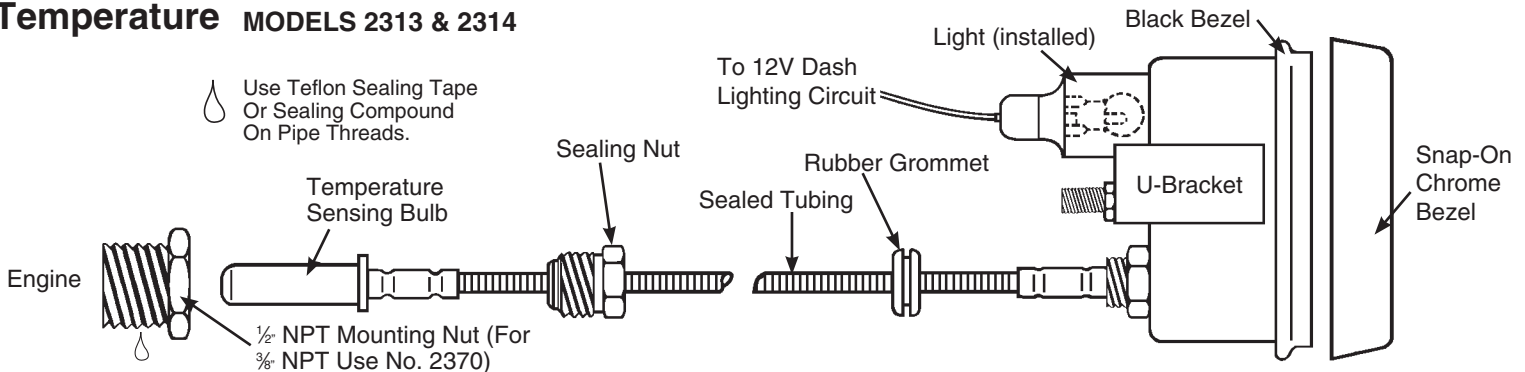

1. Gauge may be mounted in a 2 5/8" dia. dashboard hole, in Auto gage mounting panels or in Auto gage mounting cups.
2. Cut a 7/8" dia. hole in firewall. Route temperature sensing bulb through hole to engine compartment. Slit rubber grommet provided and position in firewall hole so gauge tubing is held firmly in place. If a gauge mounting cup is used install additional grommet in back of cup in same manner.
3. Thread mounting nut into the 1/2" or 3/8" NPT port on engine. Insert temperature sensing bulb in mounting nut and carefully tighten sealing nut. Make sure tubing is free from moving parts or hot engine components. The 2314 Oil Temperature Gauge usually requires drilling a hole and brazing the 1/2" NPT mounting nut into the oil pan. Check for adequate internal clearances for temperature sensing bulb in the oil pan before drilling any holes. Install temperature sender as described above.

NOTE: Use teflon sealing tape or sealing compound to assure proper seal on all pipe thread joints (NPTF).

4. Start engine and inspect installation for any leaks.
5. Snap-in light socket assembly and connect to dash lighting circuit or other 12 volt power source.

IMPORTANT: Should you ever need to remove the temperature sensing bulb, loosen the sealing nut without allowing the mounting nut to rotate. Failure to follow this procedure may result in internally broken capillary tubing, which would void the warranty.

Fuel Level MODELS 2315, 2316, & 2320

NOTE: For the following installation **THE GAS TANK MUST BE FULL!**

1. Disconnect negative (-) battery cable. (Wear safety glasses)
2. Gauge uses vehicle's stock sender in fuel tank. Existing wires may be used or route proper length of 18-gage, 2 conductor wire from fuel tank to gauge. Connect one end to terminal post on fuel level sender and the opposite end to the sender terminal post (S) on back of gauge. See figure.
3. Connect wire from negative (-) terminal post on back of gauge to ground on fuel tank.
4. Connect wire from ignition switch to the positive (+) terminal post on back of gauge. See figure on right. CAUTION: Be careful not to touch ignition wire to the sender terminal (S). This will damage the sender.
5. Snap-in light socket assembly and connect to dash lighting circuit or to other 12 volt light source. If dash is metal, a ground connection for light is made when gauge is mounted with brackets provided. If dash is non-metallic (or if gauge is cup mounted), a separate ground wire must be connected from gauge case stud to a good ground.
6. Reconnect negative (-) battery cable and check reading.

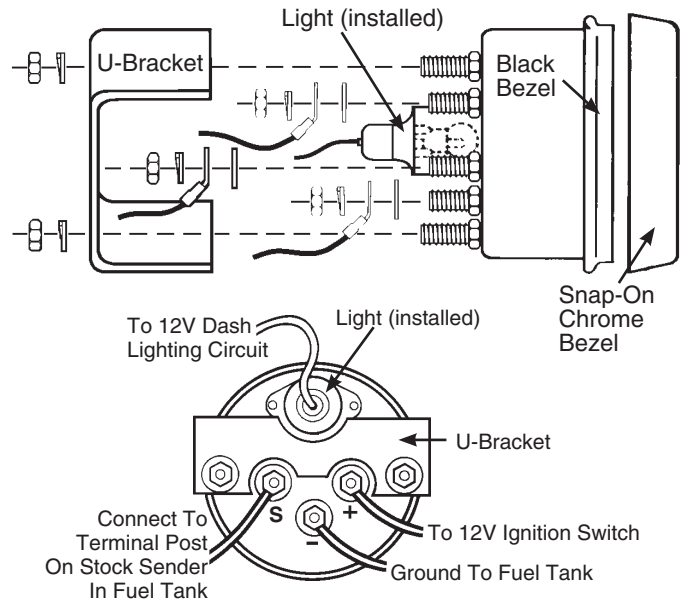

Gauge Specifications

This gauge is designed to operate with the original sender in the vehicle's fuel tank. To insure accurate gauge readings, it is important to measure the resistance (ohms) of the sender with an ohmmeter at full and empty tank conditions. Consult table for proper gauge application for your vehicle.

NOTE: Production tolerances in the resistance of some vehicle's tank senders may cause the gauge to read incorrectly when tank is full.

APPLICATION	SENDER RESISTANCE (OHMS)		Gauge Model No.
	FULL	EMPTY	
FORD/CHRY.	8 to 12	73	2315
GM	90	0	2316
No. 3262 sender	33	240	2320

Installation

IMPORTANT: The 2311 Fuel Pressure gauge must be mounted outside of the vehicle's interior, such as on the cowl in front of the windshield. This is required to prevent the possibility of fire or explosion in vehicle interior.

1. Determine best location for mounting the Fuel Pressure gauge on vehicle's exterior. Mounting cup kits are available for mounting gauges on vehicle's cowl in front of windshield. Drill necessary hole and install rubber grommet where pressure line passes through sheet metal.
2. Braided stainless steel tubing is recommended because of the highly flammable nature of racing fuel. **DO NOT USE NYLON OR COPPER TUBING WITH COMPRESSION FITTINGS.**
3. Route pressure line through grommet to engine compartment, keeping line free from hot engine components or moving parts. Plumb line into vehicle's fuel line. Be sure to use teflon sealing tape or compound on all tapered threads for a good seal.
4. Start engine and thoroughly check for any leaks.
5. Snap-in light socket and connect wire to dash lighting circuit or to other 12 volt source. A separate ground wire should be attached to gauge case stud and to ground.

Fuel Pressure MODEL 2311

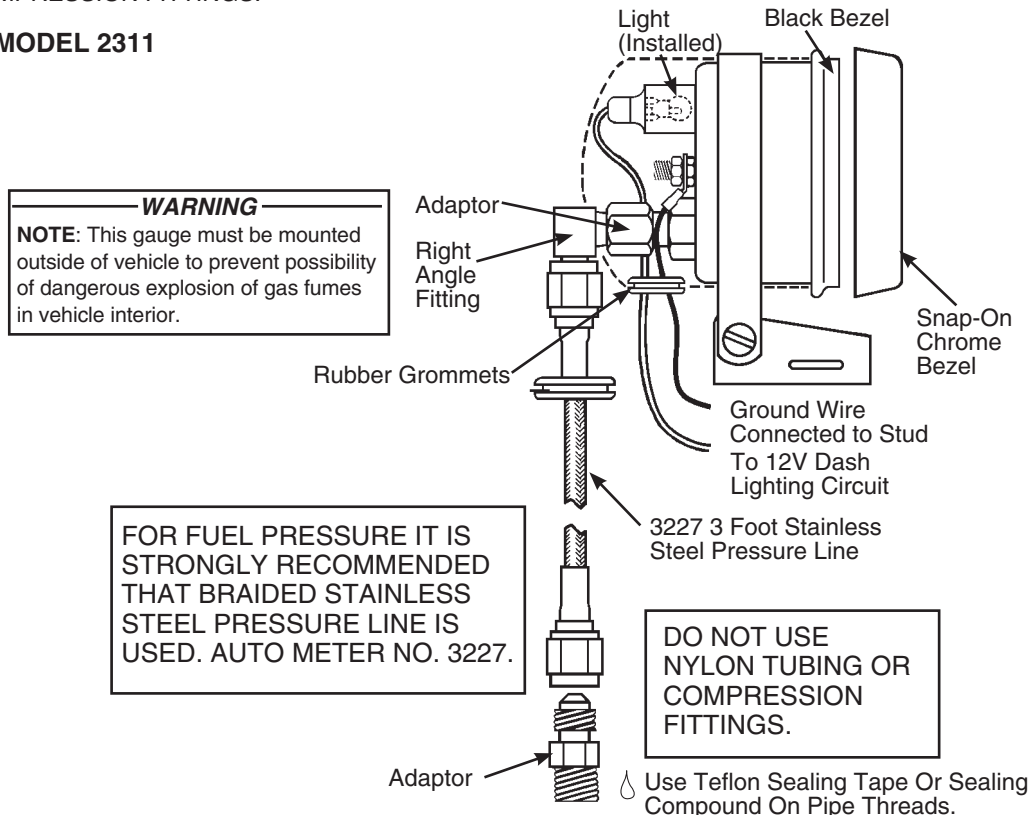

Oil Pressure, Vacuum & Boost Gauges

MODELS 2310, 2312, 2317

- Gauge can be mounted in 2 $\frac{5}{8}$ " dia. dashboard hole in Auto Meter mounting panels.
- Drill a $\frac{3}{8}$ " dia. hole and install rubber grommet where pressure or vacuum line passes through sheet metal, such as firewall.
- BOOST, OIL PRESSURE, and VACUUM gauges** require attaching nylon pressure line or braided stainless steel pressure line to port on back of gauge.
For **BOOST**, connect line to a manifold vacuum/pressure line using the fittings provided with the gauge and pressure line kits.
For **OIL PRESSURE**, connect line to the appropriate pressure port on engine.
For **VACUUM**, connect line to a manifold vacuum line using the fittings provided with the gauge and pressure line kits.
- To help prevent leaks, be sure the end of nylon tubing is cut cleanly and straight. Slide compression nut onto tubing with threads toward end of tubing. Next, slide ferrule onto end of tubing, leaving $\frac{3}{16}$ " between ferrule and end of tubing. Insert end of tubing into the $\frac{1}{8}$ " NPT male adaptor. Apply pressure to maintain constant bond between end of tubing and inside of adaptor. Slide ferrule into the adaptor then compression nut. Tighten compression nut with $\frac{3}{8}$ " open-end wrench, while

holding adaptor firm with $\frac{7}{16}$ " open-end wrench. This should form a tight seal between end of tubing and inside of adaptor. To make sure it is a snug fit, tug lightly on nylon tubing to make sure it doesn't come out.

- NOTE: Use teflon sealing tape or sealing compound to assure proper seal on all pipe thread joints (NPTF).**
- Make sure line is free from hazard of moving parts or hot engine components. Where potential hazard exists, braided stainless steel pressure line is recommended.
 - Snap in light socket assembly and connect to dash lighting or other 12 volt light source. If dash is metal, a ground connection for light is made when gauge is mounted with brackets provided. If dash is non-metallic (or if gauge is cup mounted), a separate ground wire must be connected from gauge case stud to a good ground.
 - Wrap a clean rag around fittings on back of oil pressure gauge and place a pan on floor under them to protect vehicle interior from potential oil leaking. Start engine and run for 30 seconds. Shut engine off and check rag or leaks. If none appear, start engine again and visually check all connections for leaks.

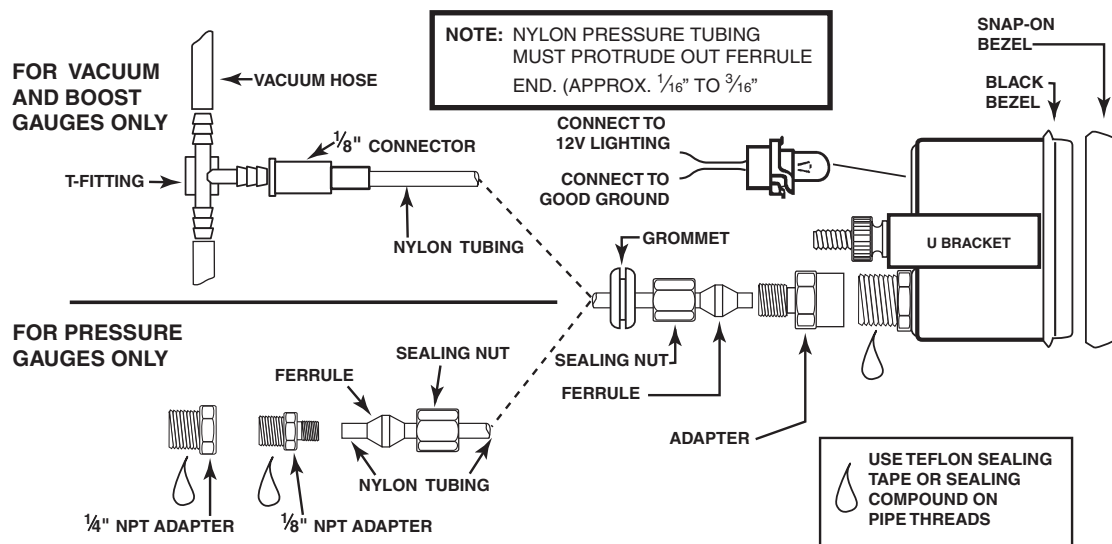

Voltmeter MODEL 2319

- Disconnect the negative (-) battery cable. (Wear safety glasses)
- Auto Meter wire kit No. 2217 (18-gage) is recommended. Route one length through firewall using grommet. Attach one end to the left hand terminal (-) on back of gauge and the opposite end to a good engine ground.
- Attach one length of wire to the right hand terminal (+) on back of gauge and opposite end to 12 volt terminal on ignition switch or to any 12 volt source.
- Snap-in light socket assembly and connect to dash lighting circuit or to other 12 volt source. If dash is metal, a ground connection for light is made when gauge is mounted with brackets provided. If dash is non-metallic (or if gauge is cup mounted), a separate ground wire must be connected from gauge case stud to a good ground.
- Reconnect negative (-) battery cable.

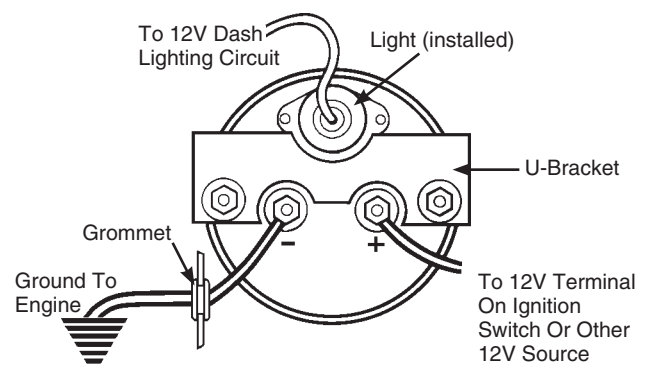

Ammeter MODEL 2318

Read before installing:

WARNING:

Have your maximum alternator output tested by an experienced mechanic. Choice of improper ammeter rating and/or wire size, and any loose connections can cause dangerous overheating, which could cause a fire in your vehicle. Ammeter and wire should have a capacity of at least 10 amps more than your vehicle's maximum alternator output.

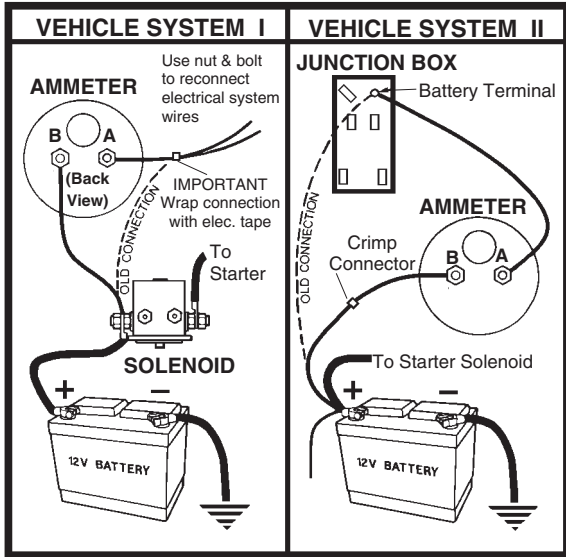

1. Read instructions thoroughly. The installation of this product requires the expertise of a trained automotive mechanic. Please consult a qualified mechanic if you have not had training in the proper installation of an ammeter.
2. Determine ideal mounting location. Choose a location that will not obstruct visibility or impair driving movement.
3. Examine your vehicle to determine the best route for wiring to follow. Choose a path free of hazard of moving parts or hot engine components.
4. Disconnect negative (-) battery cable. (Wear safety glasses.)
5. Hold panel in desired mounting location. Use panel as template and mark holes to be drilled for mounting.
6. Drill holes with 9/64" drill bit and attach panel with screws provided.
7. Auto Meter No. 2228 wire kit must be used for installation. Kits contain a premium grade wire required for safe installation.
8. **IMPORTANT:** Verify that the nuts on both meter terminals are tight. Follow wiring diagram for car system I or II, and connect ammeter as illustrated.

CAUTION

DO NOT CONNECT THE AMMETER ACROSS THE BATTERY.

9. **IMPORTANT:** Terminal lugs must be BOTH crimped and soldered to the wire, and star lockwashers must be used on both sides of the terminal lugs.
10. Tighten terminal nuts to compress star lockwashers into the terminal lugs.
11. Verify that **none** of the ammeter connections are to ground.
12. Secure gauge in mounted panel using non-insulated mounting bracket, two (2) lockwashers, and two (2) #10 nuts.
13. Snap-in light socket assembly into back of gauge. Connect red lighting wire to 12V power source in dash lighting circuit. Connect the black wires to good engine ground (such as body frame bolt).
14. Reconnect negative (-) battery cable.
15. Leaving engine **off**, turn on lights. Indicator should read negative (-). If it reads positive (+), disconnect neg. battery terminal and reverse the wires on back of meter, then reconnect neg. battery terminal. **Before** starting car, double check that all connections are tight. After starting engine, check wiring connections for hot spots. Be prepared to shut engine off **immediately** if hot spots are detected.

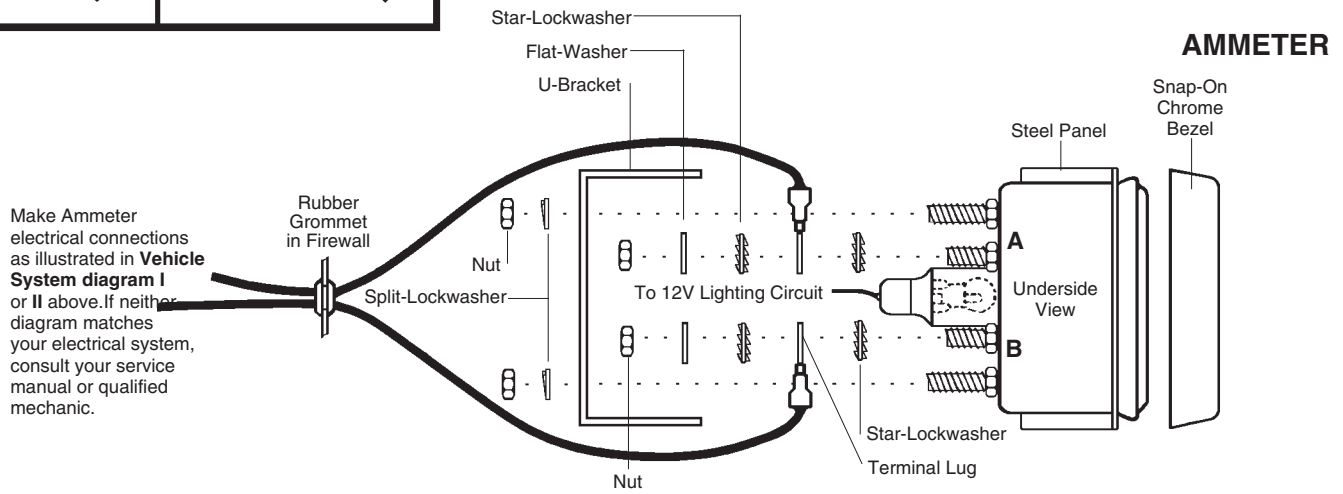

Final Procedures (For All Gauges)

1. Insert light bulb and socket assembly into back of gauge. Connect red lighting wire to 12V power source in dash lighting circuit. Connect black wires to good ground, such as dash or chassis ground bolt.
2. Reconnect negative (-) battery cable. Re-program your clock and radio if necessary.