

INSTALLATION INSTRUCTIONS ELECTRIC SPEEDOMETER



General Information

This electric speedometer utilizes a LCD to display odometer and trip odometer mileage. Momentarily pressing the Trip/Reset button on the dial window cycles the odometer, trip 1, and trip 2 displays on the LCD. Pressing and holding the Trip/Reset button for more than two seconds while in either trip mode, will reset the trip odometer currently being displayed. The odometer cannot be reset.

Auto Meter electric speedometers are pre-calibrated. When converting from a cable driven speedometer further calibration may not be needed if:

1. The transmission's speedometer cable take off is 1000 RPM at 60 MPH (97 km). Most vehicles meet this requirement.
2. The vehicle is equipped with a 16-pulse/revolution sender.
3. The speedometer that includes a 2-wire sender is pre-calibrated to 8 pulses/revolution to match this sender.

If the above conditions have not been met, the speedometer must be recalibrated (**see calibration section**). Also, if the vehicle's tire size and/or differential ratio has changed, the speedometer needs to be recalibrated.

NOTE: The odometer on this speedometer will show some mileage less than 5 miles (8 km). This is a result of factory testing to insure optimum quality.

Speedometer Senders

The speedometer is designed to operate with an electrical speed sender. The speed sender signal range must be between 500 and 400,000 pulses/mile (310 and 248,500 pulses/km). Any speed sender or electronic module that meets the following two conditions can be used:

1. Pulse rate generated is proportional to vehicle speed.
2. Output voltage within the ranges listed below:
 - Hall effect sender, 3-wire (5 to 16V)
 - Sine wave generator, 2-wire (1.4 VAC min.)
 - 5V Square wave (CMOS)

Recommended – Auto Meter Hall effect sender, 3-wire 16 pulses/revolution.

5291	Standard 7/8 – 18 thread
5292	Ford, plug in

Mounting

1. Mount a 3¹/₈" speedometer in a 3⁵/₃₂" dia. hole, a 3³/₈" speedometer in a 3³/₈" dia. hole and a 5" speedometer in a 4⁵/₈" dia. hole. Be careful not to cut the hole too large.
2. Cut a 3³/₈" dia. hole in the firewall for the speedometer wires. Place a rubber grommet in the hole and route the wires through the grommet to the engine compartment.
3. Connect the speedometer wires as shown in the wiring sections.
4. Secure the speedometer to the dashboard using the provided bracket and hardware.

3¹/₈" Models

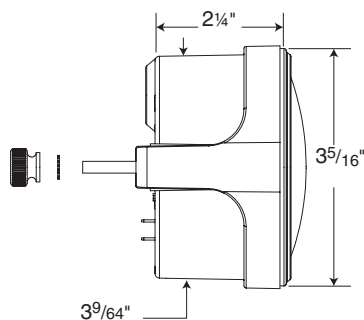

3³/₈" Models

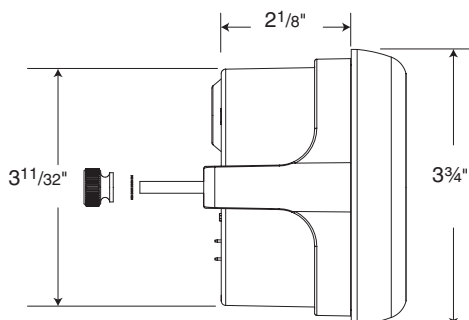

5" Models

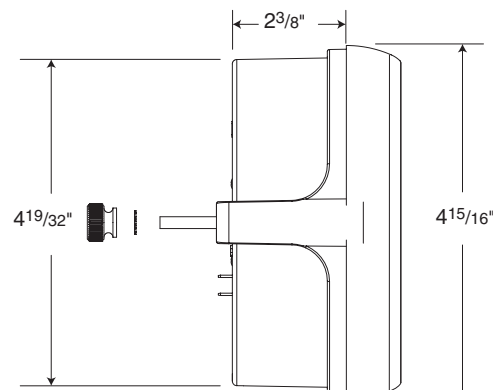

Testing

Once the speedometer is mounted and wired into the vehicle, the speedometer should be tested to verify that the electrical connections are working properly. First, watch the speedometer's pointer as the power is applied. The pointer should first move to a midrange position, then down to the 0 position on the dial. This action verifies that power is properly connected to the speedometer. The vehicle should be driven some distance to verify the Vehicle Speed Sender (VSS) is connected properly and that the pointer moves. If the pointer does not move off of the zero position, verify that the VSS is connected properly. In some cases calibration may be needed if the pointer does not register speed. Follow the calibration procedure and retest.

Calibration (Electric Speedometer calibration made easy!)

To calibrate your electric speedometer:

1. With the power off, push and hold the Trip/Reset button. While holding the button, start the vehicle and continue to hold the button until the pointer sweeps to full scale and stays at full scale. You may now release the button.
2. Drive to the beginning of a pre-marked 2 mile (2 kilometer) distance and stop. It does not matter how far away it is to get to this pre-marked 2 mile (2 kilometer) mile distance. **DO NOT SHUT THE ENGINE OFF.** Push and release the Trip/Reset button. The pointer will drop to half scale.
3. Drive the 2 mile (2 kilometer) distance. The pointer will remain at the half scale position no matter what speed you drive. It will be normal to see the LCD odometer counting rapidly as it is receiving a speed signal. If you have to stop during the calibration, that is o.k. The speedometer will simply stop counting pulses during this time.
4. At the end of the 2 mile (2 kilometer) distance, stop and press and release the Trip/Reset button. The pointer will drop to 0 and the calibration is stored. You are now finished.

Remember the accuracy of your 2 mile (2 kilometer) distance will directly affect the accuracy of your speedometer.

The following list contains factors that can affect speedometer accuracy and how to minimize them during calibration.

1. Tire diameter increases slightly as vehicle speed increases. To minimize this error drive at an average speed of 45 MPH (75 KPH) during calibration.
2. Tire diameter increases slightly as tire air pressure is increases. To minimize this error, check the vehicle's tires to ensure correct air pressure.
3. Tire diameter changes with vehicle load. Minimize this error by having an average load in the vehicle during calibration.
4. Minimize tire slippage error by not breaking traction during calibration.

Note: Always recalibrate speedometer after any tire size or differential ratio change.

Wiring

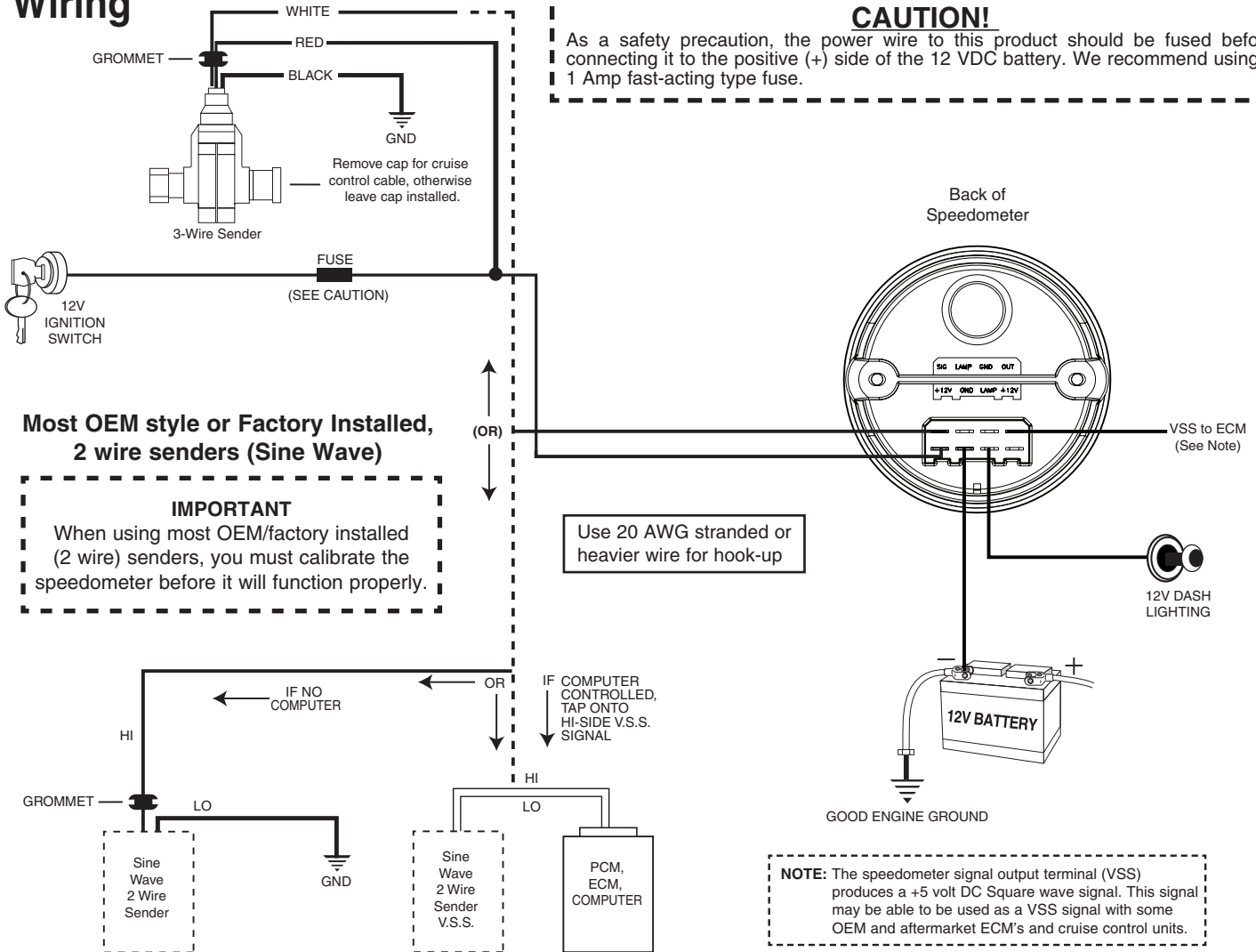

Light Replacement (Models that have incandescent lighting only)

Remove the plastic cap on the back of the speedometer. Using needle nose pliers, rotate the twist-lock lamp socket counterclockwise to remove. Replace old bulb with GE 168 bulb.