

INSTALLATION INSTRUCTIONS TACH/SPEEDO COMBO

2650-1175-00



General Information

The electronic speedometer in this instrument utilizes a single LCD to display odometer and two trip odometer mileages. Press the Trip/Reset button on the dial window to cycle between odometer, Trip 1, and Trip 2 displays on the LCD. Pressing and holding the Trip/Reset button for more than 2 seconds while viewing either Trip display will reset the trip currently being displayed. The odometer cannot be reset.

NOTE: The odometer on the speedometer portion of this instrument will show some mileage less than 5 miles (8km). This is a result of factory testing to ensure optimum quality.

TIP: Auto Meter always recommends performing the calibration process for best speedometer accuracy.

Speedometer Senders:

The electronic speedometer in this instrument is designed to operate with an electrical speed sender. The speed sender signal range must be between 500 and 400,000 pulses/mile (310 and 248,500 pulses/km). Any speed sender or electronic module that meets the following two conditions can be used:

1. Pulse rate generated is proportional to vehicle speed.
2. Output voltage within the ranges listed below:
 - a. Hall effect sender, 3 wire (5 to 16V)
 - b. Sine wave generator, 2-wire (1.4 VAC min.)
 - c. 5v Square Wave (CMOS)

Recommended – Auto Meter Hall effect sender, 3 wire, 16 pulses/revolution
5291 Standard 7/8" – 18 Thread
5292 Ford, plug in

Installation Tips

1. A 12 V power source **MUST** be used to power this tachometer. A 12V motorcycle battery is a good alternative for cars without batteries. A battery with minimum 5 amp hour rating is recommended.
2. Wherever possible, solder wire connections and avoid crimp-type connectors. This will minimize loose connections that could cause problems later.
3. Make sure you have a good ground to engine and battery negative terminal.
4. Wire installations should be neat and tied down to prevent tugging and fraying of wires at connections.

Trouble Shooting

If your tach/speedo does not function properly after installation check the following:

1. Are all electrical connections correct and tight?
2. If neither the tach/speedo nor dial light work, check ground and 12V power connections.
3. Disregard tach/speedo readings that occur before engine is started.
4. If problems persist try the tach/speedo on another vehicle with the same ignition.
5. For changes in ignition type, contact a service representative from Auto Meter.
6. Ignition manufacturers recommend that the ignition and coil be matched according to criteria which they establish (often that the ignition and coil be products of the same company). If they are mismatched, minor malfunctions may occur, showing as erratic readings on the tach. Mismatching coil and ignition types are often the cause of incorrect tach performance.

Wiring

CAUTION!

As a safety precaution, the power wire to this product should be fused before connecting it to the positive (+) side of the 12 VDC battery. We recommend using a 1 Amp fuse.

WARNING

Warranty will be void if connected to coil when using an aftermarket ignition box such as, but not limited to products from the following manufacturers: MSD, Crane, Jacobs, Mallory, Holley, Etc.. Prior to installation of your tachometer, check with the ignition box manufacturer for recommended tachometer signal location.

Auto Meter Hall-Effect senders (Square Wave)

- Models 5291 (standard 7/8-18 thread) & 5292 (Ford Plug in Sensor), 3 wire sender, cruise.

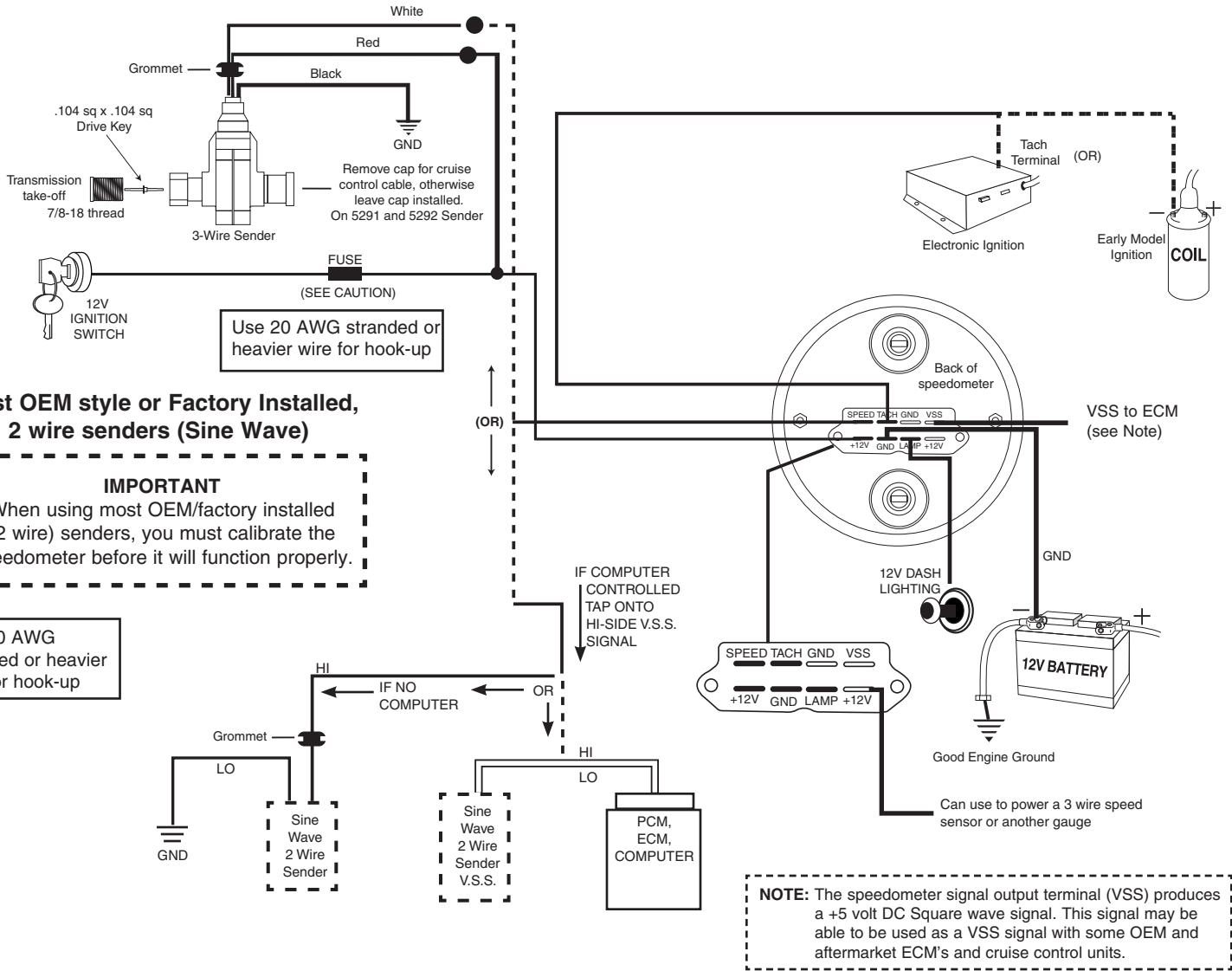

Mounting

1. Mount a 3 3/8" tach/speedo in a 3 3/8" dia. hole and a 5" tach/speedo in a 4 1/2" dia. hole in the dashboard. (be careful not to make the hole too large.)
2. Cut a 3/8" dia. hole in the firewall for the tach/speedo wires. Place a rubber grommet in the hole and route the connector wires through the grommet to the engine compartment.
3. Connect the tach/speedo wires as shown in the wiring section.
4. Secure the tach/speedo to the dashboard using the provided bracket, and hardware.

3 3/8" Models

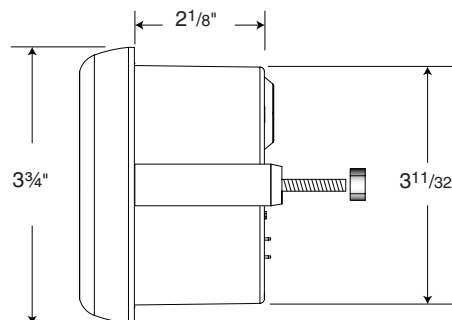

5" Models

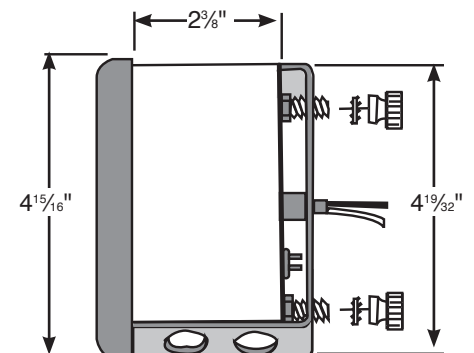

Operation

When power is first applied to the gauge, the odometer will display the current, PPM calibration, then the current, PPR calibration. Then it enters normal operation mode and displays the odometer or trip miles, depending on the state of the odometer (total miles or trip) when it was last turned off.

Testing

Once the instrument is mounted and wired into the vehicle (see preceding page), the instrument should be tested to verify that the electrical connections are working properly. First, watch the instrument's pointers as power is applied with the key in the accessory position. The pointers should first move to a midrange position, then down to the zero position on the dial. This action verifies that power is properly connected to the instrument. Start engine. Tach should show idle RPM. The vehicle should be driven some distance to verify the Vehicle's Speed Sender (VSS) is connected properly and that the pointer moves. If the pointer does not move out of the zero position, verify that the VSS is connected properly and that calibration has been performed

Calibration (Electronic Speedometer calibration made easy!)

To calibrate your electronic speedometer:

- 1) With the power off, push and hold the trip/reset button. While holding the button, start the vehicle and continue to hold the button until the pointer sweeps to full scale and stays at full scale. You may now release the button.
- 2) Drive to the beginning of a pre-marked 2 mile distance and come to a stop. It does not matter how far away it is to get to this pre-marked 2 mile distance. DO NOT SHUT THE ENGINE OFF. Push and release the button. The pointer will drop to half scale.
- 3) Drive the 2 mile distance. The pointer will remain at the half scale mark no matter what speed you drive. If the speedometer has a LCD display odometer, it will be normal to see it counting rapidly as it is receiving a speed signal. If you have to stop during the calibration, that is o.k. The speedometer will simply stop counting pulses during this time.
- 4) At the end of the 2 mile distance, come to a complete stop and push and release the button. The pointer will drop to 0 and the calibration is stored. You are now finished. Remember the accuracy of your 2 mile distance will directly affect the accuracy of your speedometer.

The following list contains factors that can affect speedometer accuracy and how to minimize them during calibration.

1. Tire diameter increases slightly as vehicle speed increases. To minimize this error drive at an average speed of 45 MPH (175 KPH) during calibration.
2. Tire diameter increases slightly as tire air pressure increases. To minimize this error, check the vehicle's tires to ensure correct air pressure.
3. Tire diameter changes with vehicle load. Minimize this error by having an average load in the vehicle during calibration.
4. Minimize tire slippage error by not breaking traction during calibration.

Note: Always recalibrate your speedometer after any tire size or differential ratio change.

PPR (Tachometer Calibration)

With the power off, push and hold Odometer Trip button

While holding the button, turn power on to gauge by turning the key to the accessory position, and continue to hold trip button in while pointer moves to 1/2 scale. Release the trip button once the pointer reaches 1/2 scale. The Odometer will show 0.5

NOTE: If the Trip button is held for 2 seconds or more, the gauge will enter PPM set mode. If this happens, press and release the Trip button. The pointer will move to 1/2 scale. Press and release the Trip button again. The pointer will move to the zero position. Turn off the power to the gauge and repeat the PPR set procedure from the beginning.

The Odometer display will change, every 1.25 seconds to 1.0, then 1.5,2.0,2.5,3.0,3.5,4.0,4.5,5.0,5.5,6.0, and back to 0.5. It will continue to cycle in this manner until the Trip button is pressed for 1 second and released. This enters the displayed PPR value and exits field cal mode.

ENGINE		Most 2 cyl.		Most 4 cyl.		Most 6 cyl.		Most 8 cyl.				
PPR	0.5	1	1.5	2	2.5	3	3.5	4	4.5	5	5.5	6