



## **BVA-36<sub>s</sub>** **Manual**

### ***Professional Accuracy in a Carbon Pile Tester.***

BVA-36 is an 800 Amp carbon pile battery load tester based upon the traditional BCI standard. The BVA-36 will also test a 12 Volt alternator, and perform a starter draw and voltage drop test.

## CONGRATULATIONS!

You have chosen one of Auto Meter's popular Charging System Analyzers. The BVA-36 is designed to test each component of a vehicle's charging system. If you should have any further questions after reading this manual see the back cover for contact information.

BVA-36 Load Test Capacity---- 800 Amp – 6&12 Volt  
Meters ----- Two Digital, 34" Characters  
Amp Ranges----- Digital, 0-1200  
Volt Ranges----- Digital, 0-19.99, 20.0-199.9  
Cooling----- 5" Internal Fan  
Load Leads -- (2 Conductor) 2 Gauge/18 Gauge 1- ft  
Volt Leads -----(2 Conductor) 16 gauge 10 ft  
Inductive Amp Probe ----- 10ft.  
Size ----- 10 1/4" x 13 1/8" 12 1/4"  
Weight----- 28.5 lbs.  
Stand -----ES-8 Optional  
Finish ----- Red Powder Paint

### **What to Expect from the BVA-36 and BVA-6:**

Load tests 6 and 12 Volt Battery and performs a complete charging system analysis on a 12 Volt system and will check the regulation on a 24 Volt alternator but will not load the system. The examples illustrated are for a 12 Volt system. See appendix for multiple batteries of 6 and 12 Volt.

**NOTE: CHARGING RATES VARY AND DEPEND ON:**

**The battery capacity rating (in minutes):**

The higher the rate... the longer the charging time required.

**The degree of discharge:**

A fully discharged battery requires 2 x's as much charging as 1/2 charged battery.

**The battery condition and age:**

An old battery and/or one in poor condition requires more charging time.

**The electrolytic temperature:**

The colder the temperature... the longer the charging time required.

**Recommended charging rates for fully discharged batteries.**

Battery Reserve Capacity (min.)	Charge Battery At: (slow charge on top fast charge on bottom)
80 minutes or less	14 hrs. at 5 amps or 7 hrs. at 10 amps
81-125 minutes	20 hrs. at 5 amps or 10 hrs. at 10 amps
126-170 minutes	28 hrs. at 5 amps or 14 hrs. at 10 amps
171-250 minutes	42 hrs. at 5 amps or 21 hrs. at 10 amps
251 minutes and above	33 hrs. at 10 amps

**CAUTION: Exceeding recommended charging rates can damage battery plates and generate potentially explosive gases.**

Safety -----4  
 Cause of Battery Failure -----4  
 Inspection and Visual Check -----5  
 Care and Maintenance -----6  
 Clamp Replacement -----7  
 Controls and Functions -----8  
 State of Charge -----9  
**1** Load Test Hook Up ----- 10  
**2** Battery Load Test ----- 11  
     Load Test Results ----- 12  
**3** Starting System Overview ----- 13  
**4** Starter Draw Test -----14-15  
**5** Alternator System Overview ----- 16  
**6** Alternator Output Test ----- 17  
**7** Charging Voltage Drop Test ----- 19  
     Overall Circuit Test ----- 20  
     Positive Circuit Test ----- 21  
     Ground Circuit Test ----- 21  
**8** Starter Voltage Drop Test ----- 22  
     Overall Circuit Test ----- 23  
     Alternator Circuit Test ----- 24  
     Positive and Ground Circuit Tests ----- 24  
 Appendix A – Multiple Battery Hookups ----- 25  
 Appendix B – Battery Charging Guide ----- 26  
 Warranty Information ----- 27  
 Contact Information ----- 28

## SAFETY

- Carefully read all operating instructions before operating the BVA-36 or BVA-6.
- Wear eye protection when working on batteries.
- Be sure load is off and each test is complete before removing load clamps to prevent arcing and potential explosion from battery gases. Never remove load clamps while testing.
- Keep sparks, flames or cigarettes away from battery.
- Keep hair, hands, and clothing as well as tester leads and cords away from moving blades and belts.
- Provide adequate ventilation to remove exhaust.
- In extremely cold temperatures check for frozen electrolyte fluid before applying load. Do not attempt to Load Test or charge a battery under 20° F. (-7°C.). Allow the battery to warm to room temperature before testing or charging.
- **Warning!** Never connect load clamps to more than one 12 Volt battery at a time. Connection to a 24 Volt battery will dangerously overload the circuitry. To check and test multiple batteries and 24 Volt systems see Appendix A.
- **Warning!** Never attach the BVA-36 or BVA-6 to a battery connected to any other tester or charging unit. Damage may result.

## CAUSE OF BATTERY FAILURE

- **Incorrect Application:** Wrong size battery may have inadequate cold cranking rating for original vehicle specifications.
- **Incorrect Installation:** Loose battery hold-downs cause excessive vibration, which can result in damage to the plates.
- **Improper Maintenance:** Low electrolytic fluid or corrosion on battery connections can greatly reduce battery life and effect battery performance.
- **Age of Battery:** If the date code on the battery is old, the failure may indicate the need of replacement.
- **Overcharging:** Overcharging caused by a high voltage regulator setting or incorrect battery charging can cause excessive gas, heat and water loss.
- **Undercharging:** Undercharging caused by a faulty charging system or low voltage regulator setting can cause lead sulfate to gradually build up and crystallize on the plates, greatly reducing the battery's capacity and ability to be recharged.

## APPENDIX A - MULTIPLE BATTERY HOOKUPS

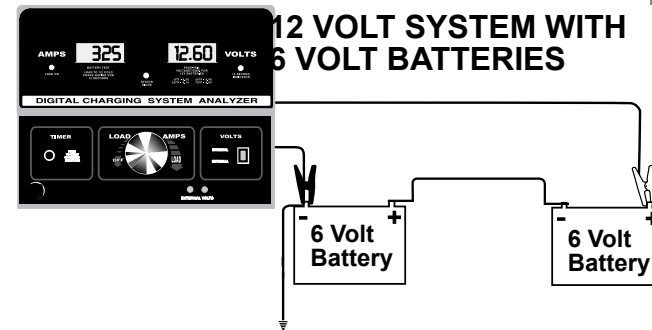

- **AMP PROBE:** Inductive Amp Probe should be positioned as indicated on the respective alternator and starter test.

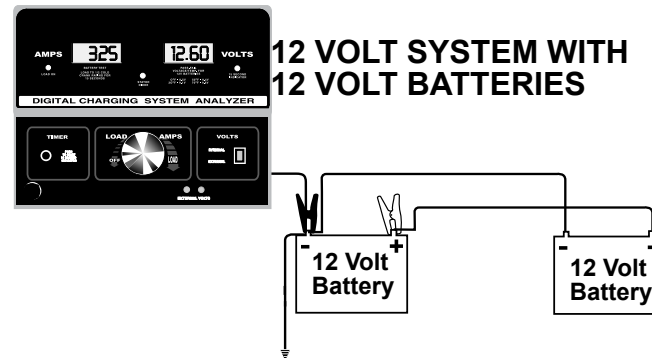

- **LOAD TESTS:** Disconnect each battery and hook up individually to do a load test.

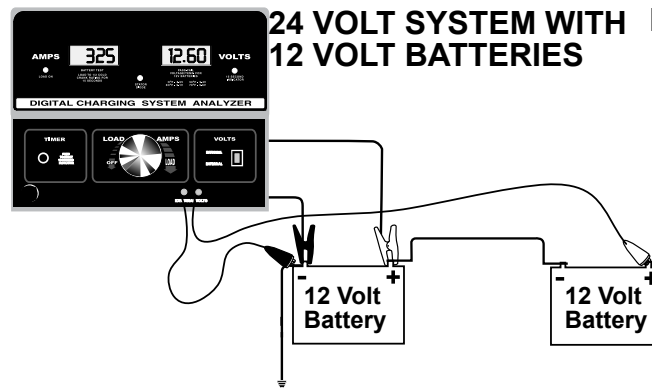

- **VOLTAGE SWITCH SELECTION** 12 VOLT SYSTEM Set volt switch to internal.

24 VOLT ALTERNATOR Check Set volt switch to external.

## WARNING

Do not use carbon pile tester to load 24 Volt batteries.

## POSITIVE STARTING CIRCUIT TEST

1. Move the small black (-) external lead attached to the (-) SG grounding surface to the (+) terminal and set the volt switch to external.
2. Crank Engine for (3) three to (5) five seconds.
3. Observe the volt drop reading by turning the volt selection switch to internal while cranking.
4. Subtract the external reading from the internal readings. If the Voltage Drop is .5V or less, positive starting circuit is OK. Go to Ground starting circuit test.
5. If the Voltage Drop is more than .5V, visually check for loose or corroded connections and frayed or undersized wires. Clean, repair or replace necessary wiring and repeat this test.

## GROUND STARTING CIRCUIT TEST

1. Return the small black (-) external lead to the (-) SG grounding surface at the Starter.
2. Move the small red (+) internal lead attached to the (+) SP terminal of the Starter to the (-) battery terminal.
3. Crank Engine for (3) three to (5) five seconds.
4. Observe the volt drop reading by turning the volt selection switch to internal while cranking. Subtract the external reading from the internal reading.
5. If the Voltage Drop is 0.5V or less, negative charging circuit is OK. If the Voltage Drop is more than .5V, visually check for loose or corroded connections and frayed or undersized wires. Clean and repair or replace necessary wiring and repeat this test.
6. Return the black (-) external lead to the (-) SG grounding surface at the Starter.

## INSPECTION

Valid automotive electrical system testing depends on all the components being in good operating condition. In addition, the battery **MUST** have sufficient charge for testing. Carefully perform the following before attempting electrical diagnosis.

### VISUAL CHECK

- **Inspect Belts** for cracks, glazed surface and fraying. Tighten loose belts.
- **Inspect Battery** for terminal corrosion, loose or broken posts, cracks in the case, loose hold-downs, low electrolyte level, moisture and dirt around the terminals.

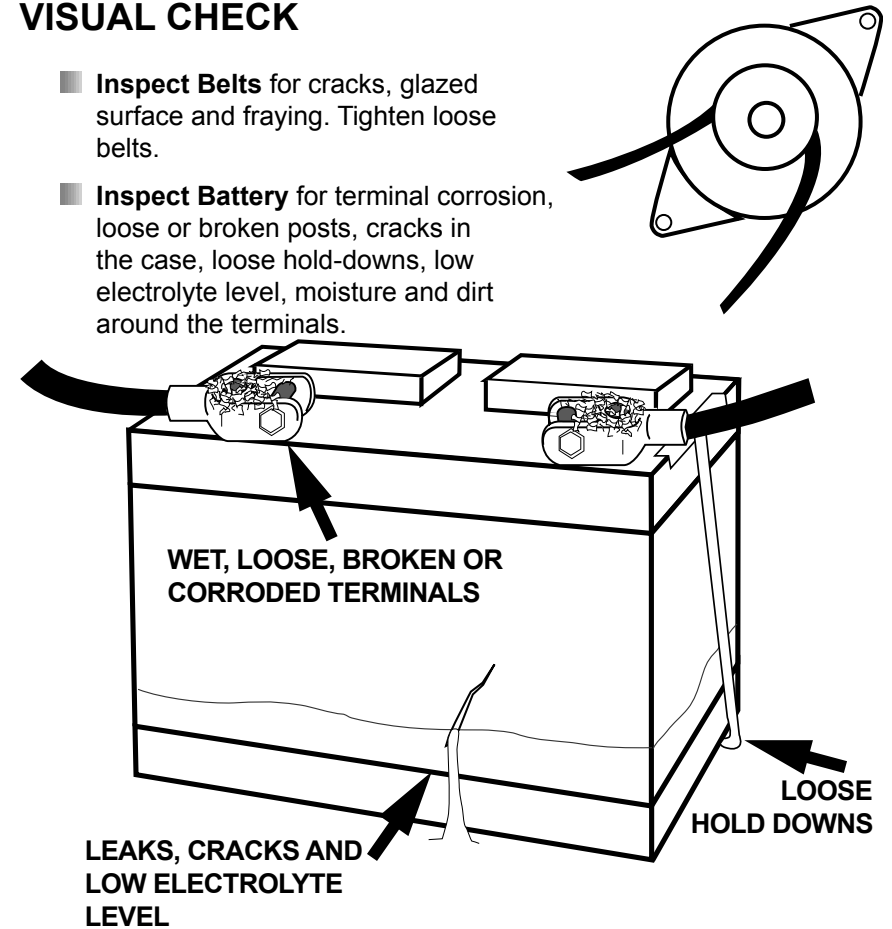

- **Inspect Starting System**: Check starter, solenoid, and regulator for loose connections, loose mounts and frayed or cracked wires.
- **Important Note**: A defective battery must be replaced before proceeding.

## MAINTENANCE

- Place the BVA-36 or BVA-6 on a secure mobile stand such as the ES-6 or ES-8
- Do not lay the inductive Amp Probe on hot surfaces. Overheating can cause damage to the probe.
- Keep Amp Probe, volt leads and clamps clean and free of dirt and oil.
- Never insert object into or cover the fan vents.
- Do not disable the auto unload feature.
- Keep the original box and packing material for safe shipping.
- If tester has not been used for a while, moisture may have condensed between carbon pile discs. Steam resulting from the first or second load after storage is not a malfunction.

### TESTER DUTY CYCLE:

To reduce wear and tear on the tester and to avoid overheating the carbon pile, follow each 15-second test with 45 seconds off before the next test is made. Excess loading of the carbon pile without a "cooling off" period could cause damage. You can make the fan run by slightly turning the load knob without applying a load for faster cooling.

### IMPORTANT:

Both jaws of each clamp must firmly engage the battery terminal. The copper jaw contains the smaller gauge wire that reads the voltage and the silver jaw contains the larger conducting wire that draws the load in each test. Jaw insulation is necessary for accurate readings. Damaged clamps or loose wires will affect the readings. Keep clamps

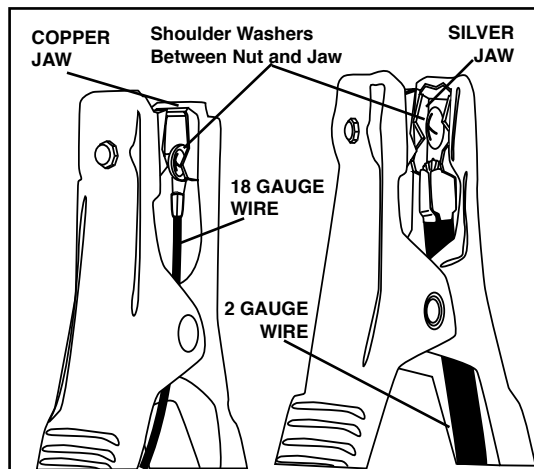

clean and in good repair. Check often for loose jaws or damaged internal plastic shoulder insulators.

## OVERALL STARTING CIRCUIT TEST

1. Make sure connections are correct as illustrated on page 22.
2. Set the Volt selection switch to external. See page 14 step 4 for disabling the ignition.

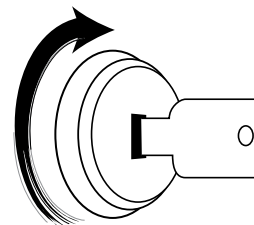
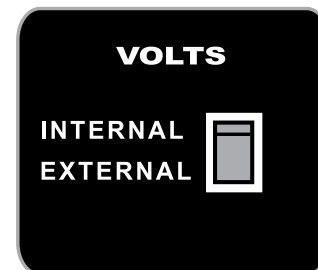

3. Crank Engine for (3) three to (5) five seconds.

4. Observe the volt drop reading by turning the volt selection switch to internal while chanking.

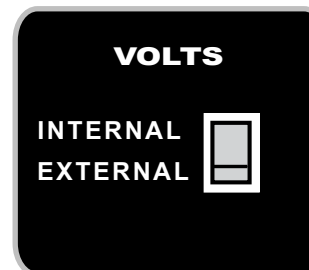

5. Subtract the external reading from the internal reading and compare to manufacturer's specifications.

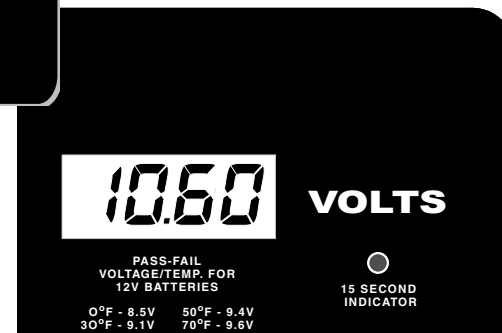

6. If the Voltage Drop is within the manufacturer's specifications, all connections and wiring within the Starting System are OK.
7. If the Voltage Drop is more than acceptable, proceed to Positive Starting Circuit Test.

## 8

## STARTING VOLTAGE DROP TEST

Loose or corroded terminal connections and damaged or undersized wires can produce resistance, which causes the voltage to drop between charging system components. Using the following procedure, Volt readings can be taken of each part of the circuit, pinpointing the voltage drops.

**Important! 24 Volt systems (Two 12 Volt Batteries) must be connected to a single temporary 12 Volt battery.**

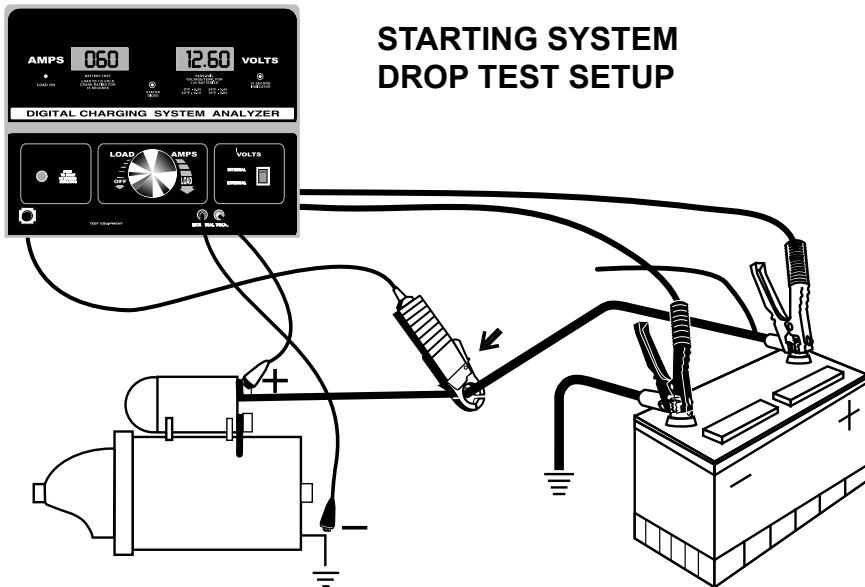

**STARTING SYSTEM  
DROP TEST SETUP**

- Hook the Tester large red (+) load clamp to the positive (+) battery terminal.
- Hook the large black (-) load clamp to the negative (-) battery terminal.
- Clamp the Inductive Amp Probe around the high current wire leaving the (+) battery and ending at the Starter (+) SP. Make sure the arrow on the probe is pointing away from the battery in the direction of the current drawn to the starter.
- Clip the small red (+) external lead to the (+) SP terminal on the Starter.
- Clip the small black (-) external lead to a clean starter ground (-) SG surface such as the Starter mounting support.

## CLAMP REPLACEMENT

Over time the battery clamps will need to be replaced if the following are indicated: CCA values seem to be way off, there is continuity between the silver and copper jaws or there is excessive damage or corrosion to the cables or clamps. Replacement procedure is as follows:

- Remove the back cover.
- Disconnect the two volt leads from the spade connectors. Note one is connected to a red (+), right wire as viewed from the rear. and the other is connected to a black (-) left wire.
- Remove the large hex bolts from the copper busses.
- Reverse the procedure in replacing new clamps.
- **Caution:** Make sure the red clamp is attached to the right buss and the black clamp is attached to the left buss as viewed from the rear. Also, the left smaller volt lead is connected to the spade connector with the red wire and the right smaller volt lead is connected to the spade connector attached to the black wire.
- Make sure your connections are secure before replacing the cover.

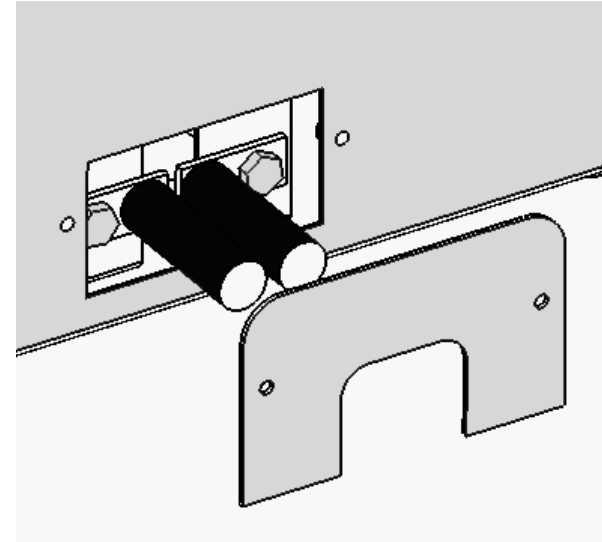



## CONTROLS AND FUNCTIONS

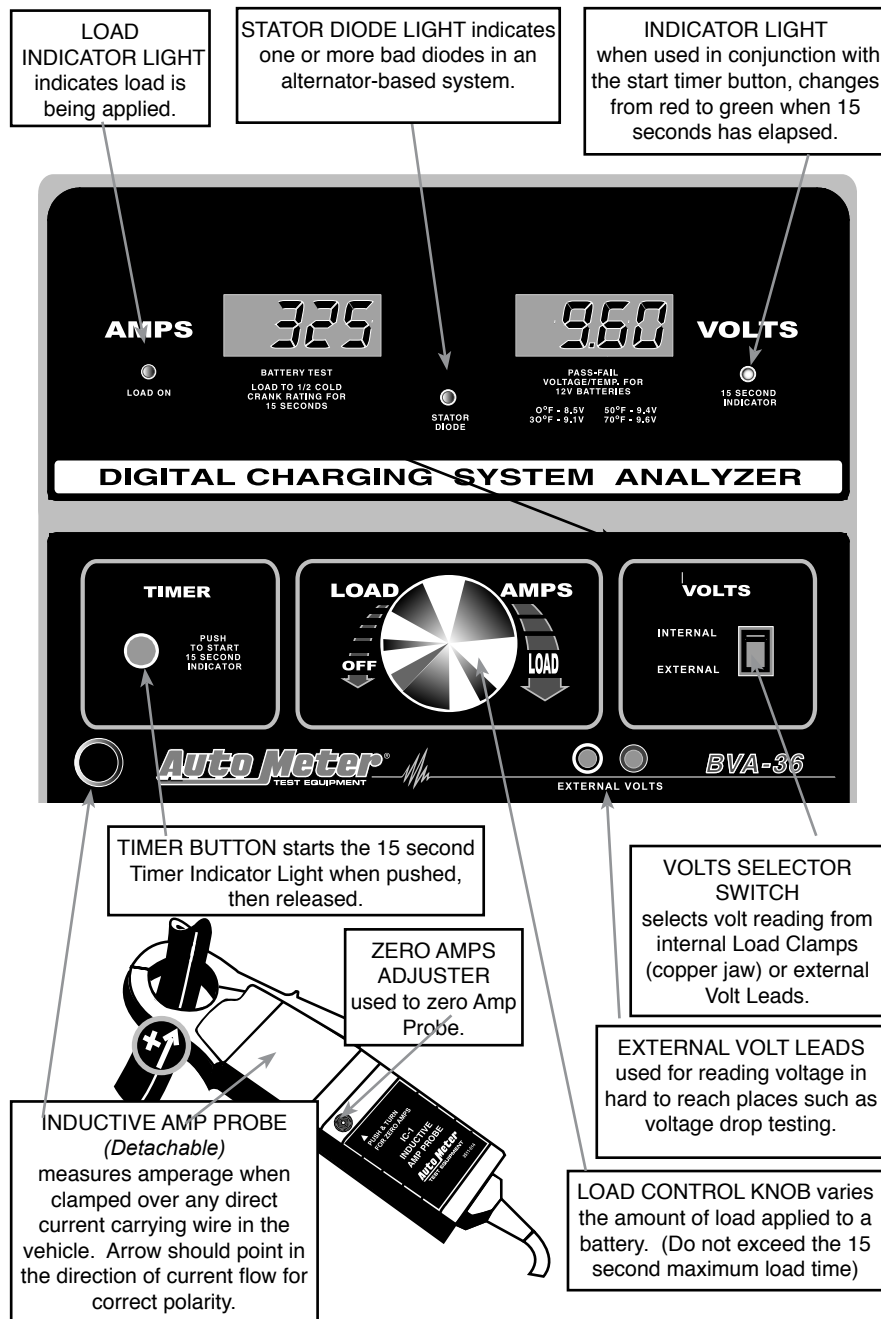

## POSITIVE CHARGING CIRCUIT TEST

1. Move the small black (-) external lead attached to grounding surface to the positive (+) terminal at the battery.
2. Set the Volt selection to external.
3. Start the Engine and allow voltage to stabilize.
4. Apply a load by turning the load knob clockwise. Increase load until the Amp meter reads the manufacturer's specification for the alternator output.
5. If the Voltage Drop is 0.5V or less, the positive circuit of the charging system is OK. Turn off engine and proceed to the Ground Charging Circuit Test.
6. If the Voltage Drop is more than 0.5V, turn off engine. Visually check for loose or corroded connections and frayed or undersized wires. Clean and repair or replace necessary wiring and repeat Positive Charging Circuit Test.

## GROUND CHARGING CIRCUIT TEST

1. Return the small black (-) external lead as illustrated in the overall setup.
2. Move the small red (+) external lead attached to positive terminal of the alternator to the negative (-) terminal at the battery.
3. Set the Volt selection to external.
4. Start the Engine and allow voltage to stabilize.
5. Apply a load until the Amp meter reads the manufacturer's specification for the alternator output.
6. If the Voltage drop is 0.5V or less the grounding circuit is OK. Turn off engine and repeat Overall Charging Circuit Test.
7. If the Voltage Drop is more than 0.5V visually check for loose or corroded connections and frayed or undersized wires. Clean and repair or replace necessary wiring and repeat Ground Charging Circuit Test.



## OVERALL CHARGING CIRCUIT TEST

1. Make sure connections are correct as illustrated on page 19.

2. Set the Volt selection switch to external.

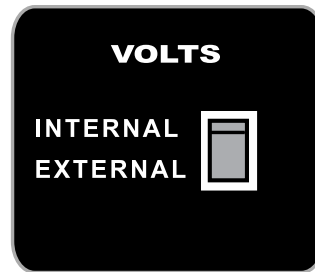

3. Start the Engine and allow voltage to stabilize.

4. Apply a load by turning the load knob clockwise. Increase load until Amp meter reads the manufacturer's specification for the alternator output.

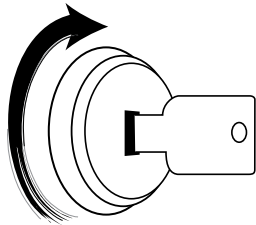

5. Observe the volt drop reading by turning the volt selection switch to internal.

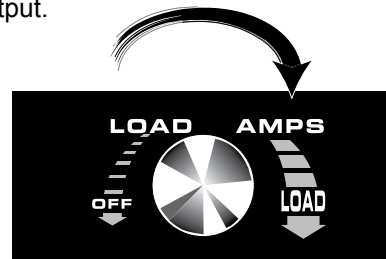
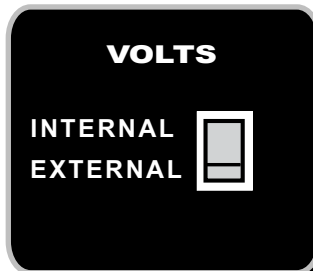

6. Subtract the internal reading from the external reading and compare to manufacturer's specifications.

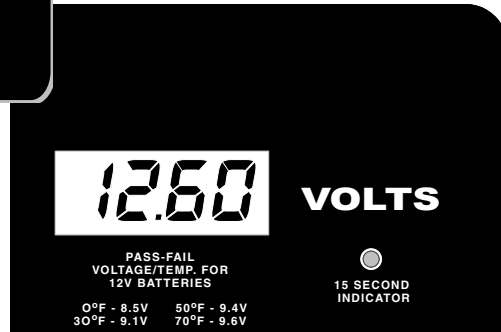

7. If the Voltage Drop is within manufacturer's specifications, all connections and wiring within the Charging System are OK. Turn off engine.

8. If the Voltage Drop is more than acceptable turn off engine and proceed to Positive Charging Circuit Test.

## STATE OF CHARGE

### Open cell batteries:

Using a hydrometer, check the specific gravity of the electrolyte fluid. Typical specific gravity values are as follows.

Reading	Indicates Battery is:
1.265	100% Charged
1.225	75% Charged
1.190	50% Charged
1.155	25% Charged

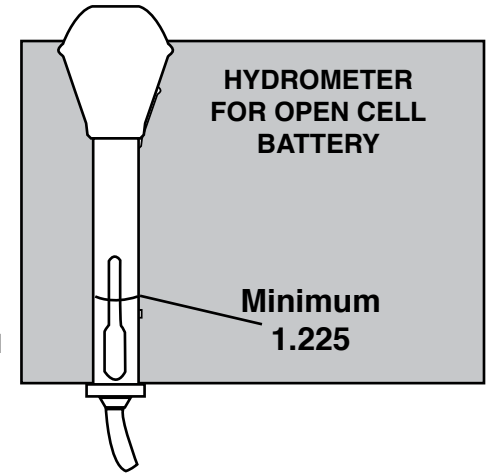

Specific gravity values are applicable to an electrolytic temperature of 80°. The values must be adjusted for temperatures other than 80°, to do this: Add .004 for every 10° over 80°. Example: At 90° 1.265 + .004 = 1.269. Subtract .004 for every 10° under 80°F. Example: at 70° 1.265 - .004 = 1.261.

Specific gravity must be 1.225 or above. If low, charge per battery manufacturers specifications. Apply a load equal to 1/2 cold crank amp rating for 5 seconds to remove surface charge. There should not be more than .05 points spread between cells. If more than 50 points, replace battery.

### SEALED TOP BATTERIES (Maintenance Free)

Battery must be at 12.4 volts (12 volt battery) or above before testing. If below 12.4, charge battery (See Appendix B - Battery Charging Guide) and apply a load equal to 1/2 cold crank rating load for 5 seconds to remove surface charge. Cold crank rating is explained under Battery Load Test. If battery reads less than 12.4 volts after recharging, replace battery. (6.2 volts for 6 volt batteries)

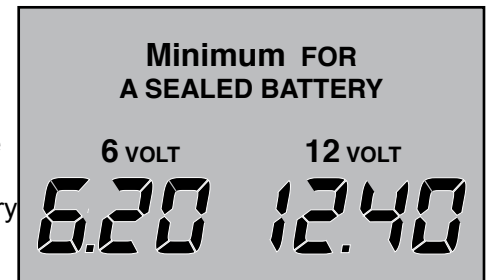

**IMPORTANT NOTE:** A defective battery must be replaced before proceeding.

# 1

## LOAD TEST HOOK UP

**Note!** Take special care when connecting to side terminal batteries. Use a side post adapter to prevent thread damage. When testing dual post batteries always check the post in which the system is attached. If a load test is made from a post connection and the alternator is mounted to side terminals, a battery load test and charge can be completed, but a continuity problem may still be in the side terminals. If tester displays a volt reading but will not load, there is a poor connection on the silver jaw of one of the clamps. If tester has no volt reading but will load, there is a poor connection on the copper jaw of one or both of the clamps.

Use Post Adapters on side post batteries

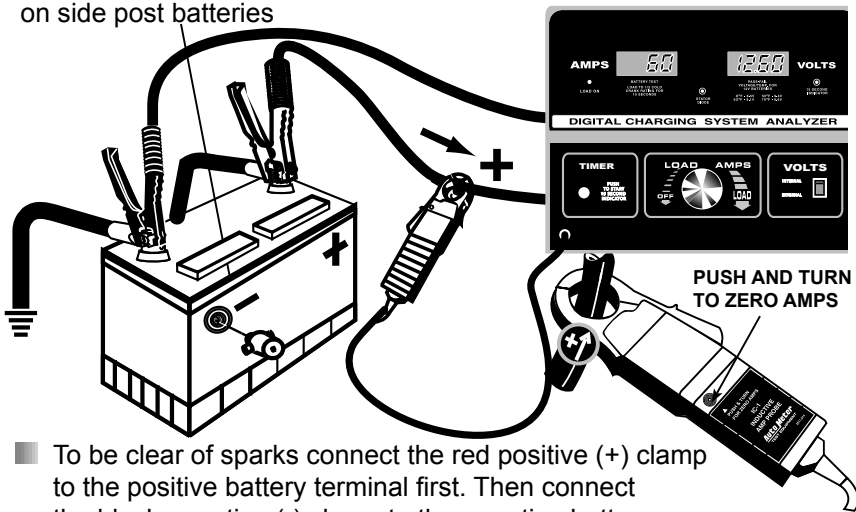

- To be clear of sparks connect the red positive (+) clamp to the positive battery terminal first. Then connect the black negative (-) clamp to the negative battery terminal.
- Zero the Amp Probe using the adjustment on the probe.
- Connect the Amp Probe to the positive cable with the arrow on the probe pointing in the direction of the tester.

### WARNING:

Do not connect large load clamps to more than one 12-volt battery at a time.

### Note:

The BVA-36 and BVA-6 will test only one 12-Volt or 6-Volt battery at a time and are designed for single battery systems only. For multiple battery hook-ups with 6, 12 and 24 Volt systems see Appendix A.

# 7

## CHARGING VOLTAGE DROP TEST

Loose or corroded terminal connections or damaged or undersized wires can produce resistance, which causes the voltage to drop between charging system components. Using the following procedure, Volt readings can be taken of each part of the circuit, pinpointing the voltage drops.

**Important! 24 Volt systems (Two 12 Volt Batteries) must be connected to a single temporary 12 Volt battery.**

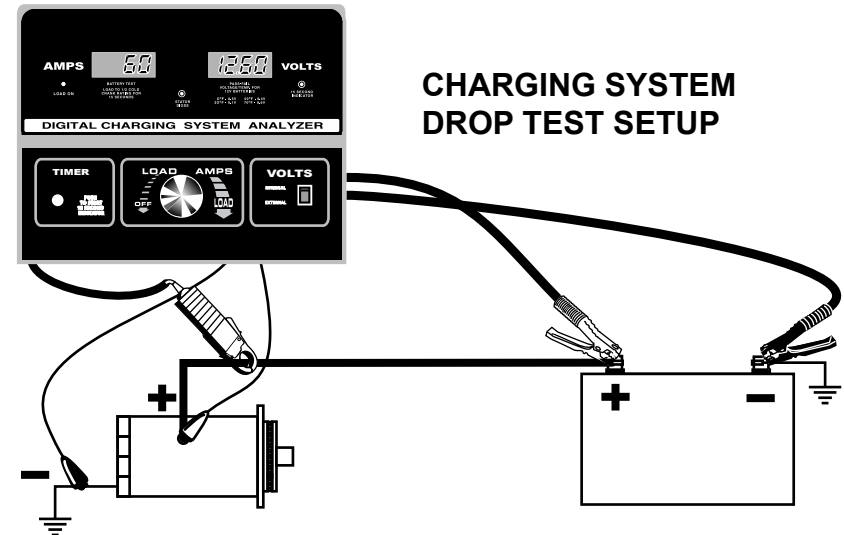

- Hook the large red (+) load clamp to the positive battery terminal.
- Hook the large black (-) load clamp to the negative battery terminal.
- Clamp the Inductive Amp Probe around the positive (+) wire leaving the alternator at (+) (AP). Make sure the arrow on the probe is pointing away from the alternator in the direction of the current supplied to the battery for correct polarity.
- Clip the small black (-) external lead to a clean alternator ground (AG) such as the mounting support.
- Clip the small red (+) external lead to the positive (+) terminal on the alternator at (AP). This circuit supplies the current going to the positive (+) battery terminal.

## READING ALTERNATOR TEST RESULTS

6. Check stator diode LED: If LED is on continuously, diode or stator is bad. Replace alternator. A bad or “open” diode or open stator windings can cause a slight drain on alternator output as well as causing other diodes to fail. This could eventually result in a failed regulator or dead battery.

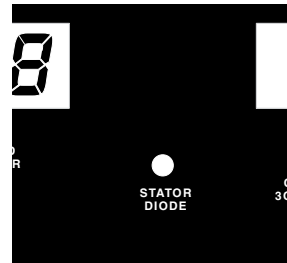

NOTE: LED may flash during transient loading, only a steady light indicates a defect.

7. Read maximum amp output of alternator and remove load. Output should be within 10-15% of manufacturers specifications.

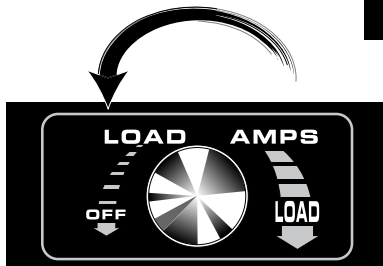
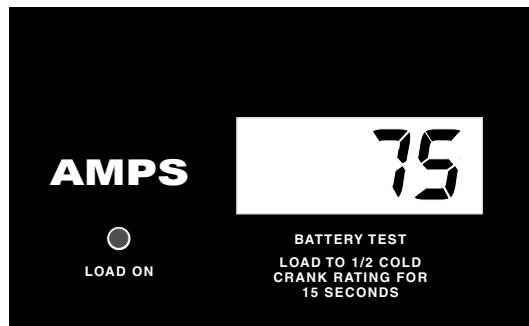

8. The fan is turned on by a slight clockwise turn of the load knob without causing any draw. Using this method you can allow the fan to remain on to cool the tester.

If output is low replace alternator.

**NOTE: Check alternator for correct size pulley. (Too large may account for low output.)**

## 2

## BATTERY LOAD TEST

A battery must be able to turn over (crank) an engine while maintaining enough current to activate the ignition system. Batteries should be able to maintain 9.6 volts with an electrolytic temperature of 70° when a recommended load is applied.

### UNDERSTANDING THE LOAD KNOB

The load knob is spring loaded with your safety in mind and to protect the carbon pile from damage. After a small clockwise turn the fan comes on. With about one quarter additional turn the load starts. Adding each turn increases

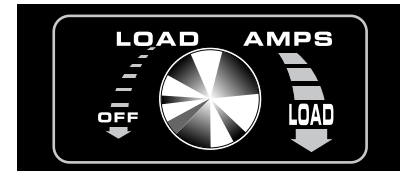

the amount of load applied. Warning: To prevent damage from continuous load tests keep the fan running 45 seconds between each 15 second load by turning the knob slightly without applying a load, otherwise allow the carbon piles to cool sufficiently before the next test.

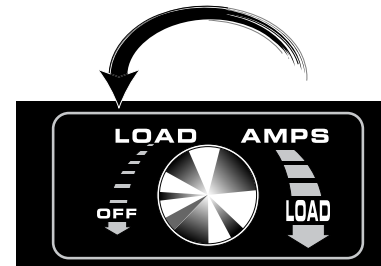

1. Be sure load is off before connecting. Hook-up each battery individually for a load test as illustrated on page 10. Do not connect tester to more than one 12 volt battery. To avoid sparks, connect negative lead to battery first and then connect positive lead. Multiple batteries must be disconnected and tested individually.

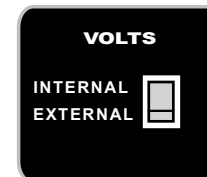

2. Set the volts switch to internal. This reads the copper jaw.

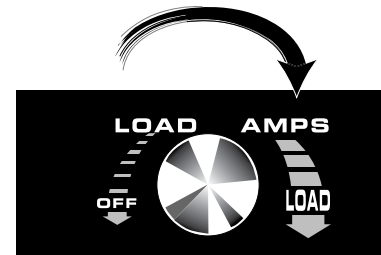

3. Apply a load equal to 1/2 cold crank rating to battery (or 3x Amp hour rating). Example: Cold crank rating 500 CCA ÷ 2 = 250 amp load. Amp hour rating: 90 amp hours x 3 = 270 amp load. Apply recommended load by turning load knob slowly clockwise.

## LOAD TEST RESULTS

4. When the amps reach the required load push the 15 second timer button and the indicator light will turn red. The recommended load must be maintained for the duration of the 15 seconds in order to accurately test the battery. The amperage will tend to drop, as a normal reaction to the gradual decrease in voltage. Turning the load knob clockwise will increase the load. Indicator light will change from red to green after 15 seconds.

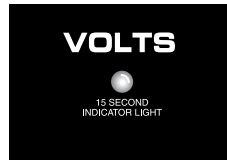
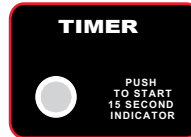
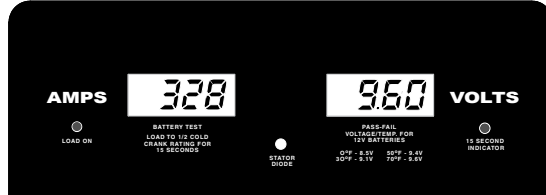

5. Observe voltage reading.

6. Estimate the temperature of the electrolyte fluid when reading the pass/fail scale. The amount of voltage a battery can maintain when a load is applied decreases as the temperature decreases. Use the voltage chart below to determine the correct minimum voltage. If voltage level was below specifications, battery should be replaced (or charged and retested). If voltage level was above specifications, battery is good.

7. Verify that the load is off.

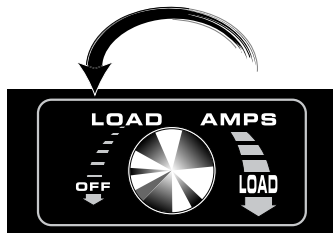

**NOTE:** The fan is turned on by a slight turn clockwise of the load knob without causing any draw. In this you can allow the fan to remain on to cool the tester.

A FURTHER LOOK...  
VOLTAGE CHART

Estimated Electrolyte Temperature	Minimum Required Voltage After 15 Sec. Load	
	12V	6V
70°F Above	9.6	4.8
60°F	9.5	4.75
50°F	9.4	4.7
40°F	9.3	4.65
30°F	9.1	4.55
20°F	8.9	4.45
10°F	8.7	4.35
0°F	8.5	4.25

### MULTIPLE BATTERY SYSTEM TESTS

For multiple batteries, the battery to be tested must be disconnected from all others.

## 6

## ALTERNATOR OUTPUT TEST

### Symptomatic Checks Before Proceeding:

- Battery should be in good condition and fully charged before testing the alternator.
- Check warning light indications.
- Check belt condition and tension.
- Check all cables and connections.
- Check the battery for corrosion and dirty terminals.
- Make sure all electrical items are off.
- Check for alternator noise.

1. Hook up the tester as illustrated on page 16.

2. Zero the Amp probe and clamp around the positive wire leaving the Alternator. In this case, make sure the arrow points away from the Alternator. This method rules out any loss of current to accessories.

3. Set the volts switch to internal setting. This reads the copper jaw.

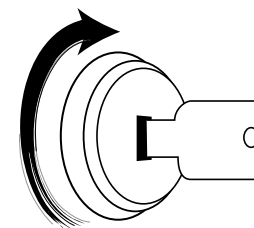
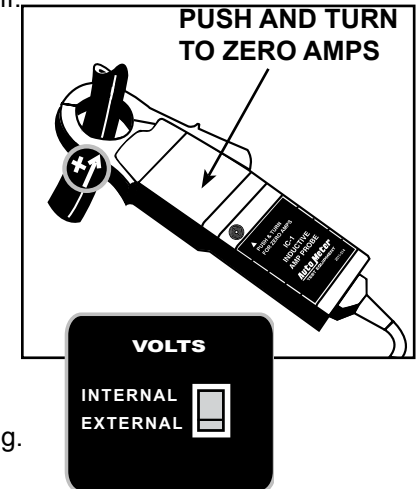

4. Start engine, idle at approximately 2000 rpm or to manufactures test rpm.

5. Slowly apply load until voltage reaches 12.4 Volts for maximum alternator output (24.8 on 24 volt systems). Use vehicle accessories if necessary to aid in applying load.

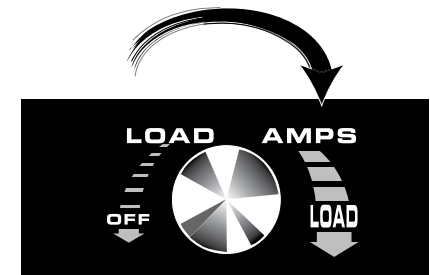

**READING RESULTS**  
See Next Page

# 5

## CHARGING SYSTEM OVERVIEW

This test accurately measures the maximum output of the alternator under maximum load conditions. This information provides the basis for further charging system tests. It also detects the presence of an open diode, which causes an output loss of several amps and can cause the failure of other diodes.

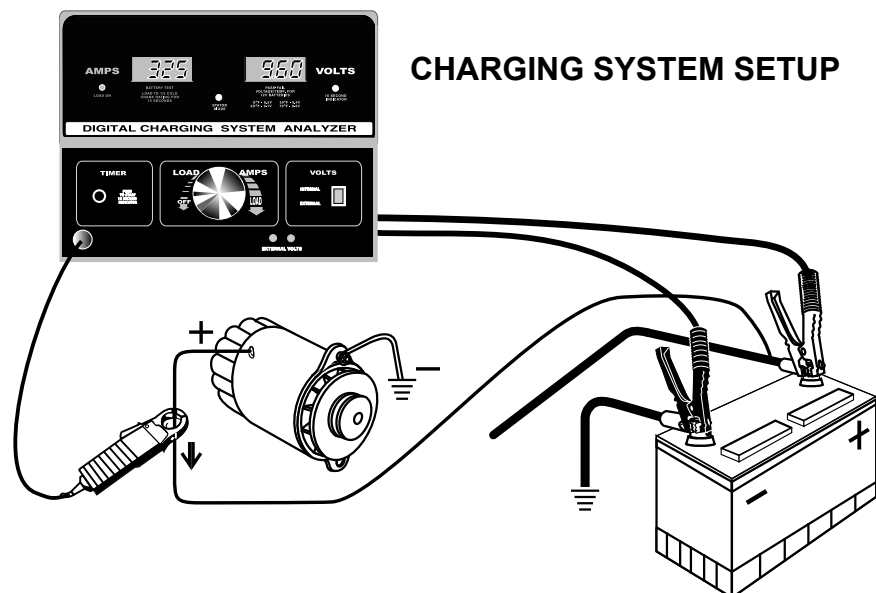

When the engine is operating, the charging system converts mechanical energy into electrical energy to supply all of the car's electrical systems as well as to maintain the battery at full charge. The alternator generates a certain level of current depending on the needs of the vehicle. Look on the alternator housing, usually a stamped current output rating is indicated. If the alternator is faulty, the maximum Amp output will be low. The alternator test measures this output. The alternator test indicates the presence of any open diodes in the system.

Loose or corroded terminals, connections, and damaged or undersized wires can produce resistance, which can cause the voltage to drop between charging system components. The VOLTAGE DROP TEST can pinpoint the source of these problems.

# 3

## STARTING SYSTEM OVERVIEW

The starter draw test measures the amount of current needed to crank the engine, which provides the initial information to diagnose and/or further test the starting system if necessary. What may appear to be a major problem may turn out to be a minor problem. In addition, what appears to be a starter may be something more major. Check the system first.

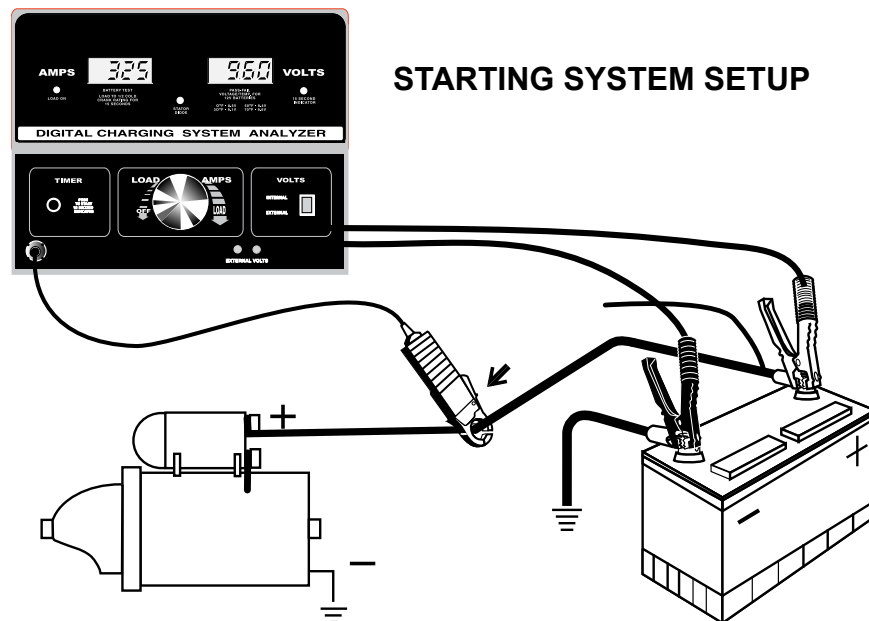

The sole purpose of the starting system is to turn over (crank) the engine fast enough for the engine to fire and run on its own. It is composed of a starter motor, a magnetic switch (usually a solenoid), a battery, an ignition switch, usually a starting safety switch, and other wires and connections. It is divided into two circuits: the starter circuit, and the control circuit. The starter circuit supplies high current to the starter motor through a relay in the solenoid. The control circuit provides low current to engage the solenoid when the ignition switch is turned to the start position.

When current is supplied, the starter turns the crankshaft flywheel. The starter draw test measures how much current the starter is drawing. If the starter draws too much current, there is a problem with the starter. If the starter draws too little current, there is probably too much resistance in the circuit or the solenoid is defective. Either of these problems can be pinpointed using the VOLTAGE DROP TEST page 22.

# 4

## STARTER DRAW TEST

### Symptomatic Check before Proceeding:

- Check all cables and connections.
- Check the battery for corrosion and dirty terminals.
- Check starter/solenoid for visual defects.
- Check the ignition switch and any magnetic switches for loose or bad wiring, loose mounting, or connections and sticking contacts.
- Check for starter/solenoid noise. The type of noise, or the lack of, can help in diagnosing the problem.
- Does the solenoid click, but the starter does not turn? Does the starter turn, but not engage the flywheel? Is the starter sluggish?

1. Hook up the tester as illustrated on page 13.

2. Zero the Amp probe and clamp to the positive wire leaving the battery. In this case, make sure the arrow points away from the battery, in the direction of the current flow.

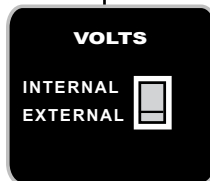
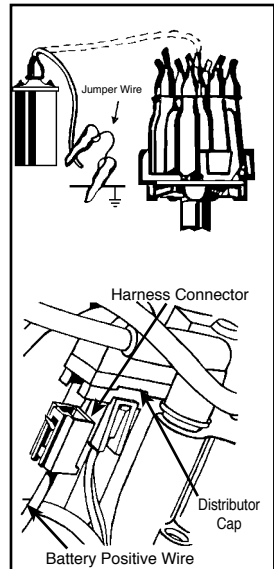
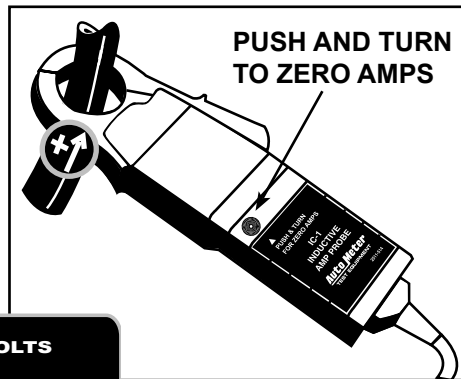

3. Set volts switch to internal volt setting.

4. Disable ignition system to prevent engine from starting when cranking.

- For point type ignitions remove coil wire from distributor tower and securely ground it.
- For electronic ignitions disconnect power to the ignition by disconnecting it from the wiring harness.
- On diesel vehicles, disconnect the fuel shut-off solenoid.

Check with manufacturer's proper procedure to disable ignition. Improper method could cause damage to vehicles that are computer controlled.

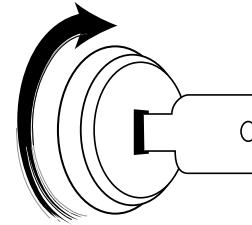

5. Crank engine for 3-5 seconds. Consider the starter sound, does it sound sluggish?

NOTE: A remote starter switch can be used to bypass the ignition switch and "crank" the engine from under the hood.

6. Read amps:

Observe amp meter reading. If within specifications, starter system is O.K. If manufacturers specifications are not available the chart below can be used as a general guideline.

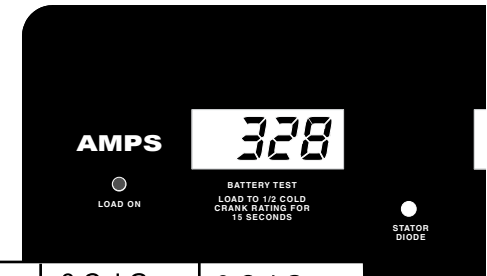

4 Cyl Gas 120-250A	6 Cyl Gas Up to 250A	8 Cyl Gas Up to 250A
4 Cyl Dsl Up to 350A	6 Cyl Dsl Up to 450A	8 Cyl Dsl Up to 650A

7. Compare Results:

#### If out of specifications:

- Check cables and connectors for excessive voltage drop.
- Repair or replace any defective cables or connectors.
- Retest system.

#### If still out of specifications:

- A high amp reading indicates a faulty starter. Some possible causes are shorted windings, bent armature, broken housing or bad bearings. Repair and replace starter as needed.
- A low amp reading (under 150 amps) indicates a faulty solenoid. Repair or replace solenoid as needed.

#### Multiple battery systems:

- If more than one positive cable connects directly to the starter the individual amp readings from each cable must be added together to determine starter draw.