



AC-14 Internal Printer Installation Manual

For use with the Xpress XTC-150 and BVA-2100

The AC-14 Internal printer allows for individual test printouts with complete test results. Results can also be printed from Auto Meter's hand-held testers using an infrared signal.

PRINTER INSTALLATION

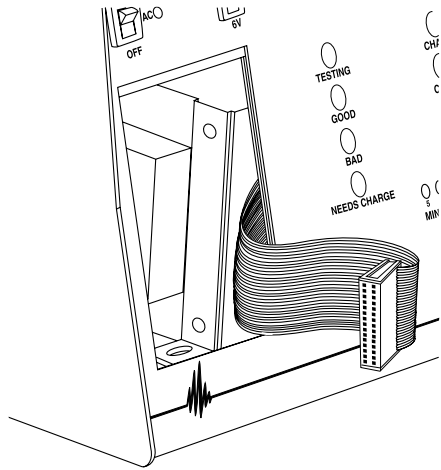

1. **Shut off tester**, disconnect any load clamps from the battery and unplug the unit from any AC source before installing the AC-14 printer..
2. Loosen the thumbscrew at the bottom of the printer cover plate and remove entire cover. Save cover if you think you might want to use your tester without a printer. Do not operate without the printer or cover plate installed.
3. Carefully pull the printer ribbon cable through the door opening as shown in the illustration above, but do not disconnect the cable from the PC board located just behind the front panel.
4. Align the ribbon cable parallel to the printer as shown below. The printer ribbon wraps in front as shown. *Do not twist or fold the ribbon cable.*
5. Carefully attach the ribbon connector to the connector located on the printer circuit board. Use care and do not force.
6. Install the printer making sure the ribbon is on the outside of the paper shield and is not crimped at the door edge. Insert the top tab under the panel before tightening the thumbscrew.

Standard 58mm roll thermal paper is available at most office supply stores.

Infrared Receiver

This window should be kept clear of obstructions if an Auto Meter hand-held tester is used to send an infrared signal.

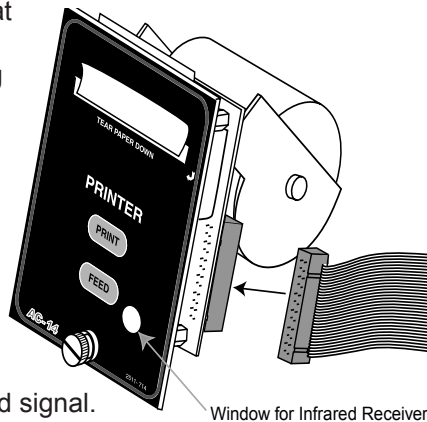

NOTE: If the infrared receiver on the printer is exposed to direct sunlight, the printer may not function properly. Turn the printer so that the infrared receiver is not exposed to direct sunlight, and reduce the printing distance from hand held testers.

PRINTER OPERATION

With the BVA-2000 & BVA-2100 you may manually print after each test. Simply press (PRINT). Results are displayed at the end of each test or when a review of a previous test is displayed on the LCD.

Xpress XTC is automatically set to print after each test. You can change the default to manual printing (see XTC printing options). The results will not print until the test is completed and the results are displayed. Note: Tear the paper with a downward motion to provide even separation and avoid jamming of the next printing.

XTC Printing Options:

You have the option to set the printer to print automatically after each test or only when you press the (PRINT) button. Example: if the printer automatically prints test results and you would prefer manual selection make sure battery is disconnected then do the following:

1. Turn off the AC power
2. Press and hold the print button
3. Turn on the AC power

The option has now been changed. If the reverse is desired repeat the same procedure.

Changing Paper:

1. **Shut off tester** and disconnect clamps from any battery.
2. Loosen the thumbscrew at the bottom of the printer.
3. Carefully remove the cover.
4. It is best not to disconnect the ribbon cable. However, if it is disconnected make sure the top edge of the ribbon is aligned with the top of the printer before reconnecting. Do not twist the ribbon cable. Make sure the pins are aligned properly. Do not force, but make sure the connection is solid.
5. Replace the new paper roll by feeding it under the roll and over the PC board as illustrated on the paper shield label. Turn on the BVA-2000, BVA-2100 or XTC-150. Press the FEED button to advance the paper. Press feed again to stop paper once it is loaded. Printer will automatically stop the feed in 10 seconds. **Turn unit off before reinstalling in case.**
6. Reinstall printer by inserting the top tab under the panel and tightening the thumbscrew. Be careful not to damage the printer ribbon.



CHECKING FOR PAPER JAM

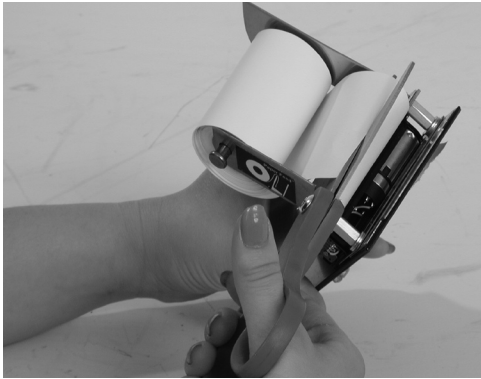

1. If paper is still in the printer, cut at paper roll.

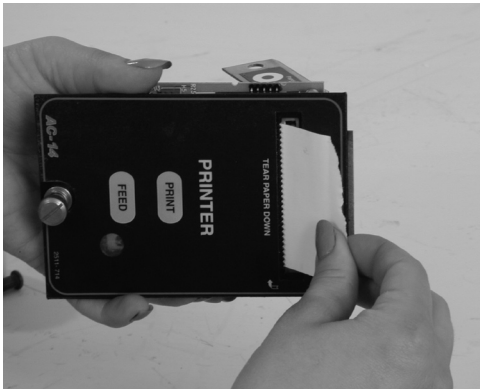

2. Pull paper out from front. Pulling paper from the back could tear paper and leave jammed section inside. Reload paper.

TO PREVENT FUTURE PAPER JAMS



1. Wait until the printer is completely finished printing before tearing paper off.

2. Always tear the paper in a downward motion.

For Technical support see back cover for contact information.

Standard 58mm roll paper is found at most office supply stores.