



# UNIVERSAL GAUGE WIRE HARNESS



For Installing Auto Meter Electric Speedometer, Tachometer, And Short Sweep Electric Oil Pressure, Water Temperature, Fuel Level, and Volt Meter Gauges.

### **This harness is for the following:**

This harness is intended for Auto Meter brand instruments  
Short Sweep Electric gauges (Oil, Water, Fuel, Volt)  
Electric in-dash tachometer  
Electric Programmable Speedometer  
Electric GPS Speedometer  
Incandescent or LED equipped gauges  
Turn signals (power controlled)  
Hi Beam indicator (power controlled)  
Park Brake indicator (ground controlled)  
Brake warning, or Park Brake indicator

### **This harness is NOT intended for the following:**

Full sweep digital stepper motor gauges  
Digital display gauges  
Tach/Speedo combo (speedometer with tachometer in the same gauge)  
Quad gauges (4 gauges in one)  
Dual gauges (2 gauges in one)  
Mechanical gauges

### **What is supplied:**

- (1) Main wire harness (gauge side & vehicle side)
- (1) Lighting ground wire harness
- (8) Red butt connectors
- (8) Male crimp on connectors
- (2) Green turn signal LED's
- (1) Amber hi-beam LED
- (1) Red brake warning LED

### **Recommended Tools & Supplies:**

- Test light
- Hand held volt meter (DVOM)
- Wire strippers
- Wire crimpers
- Your choice of wire splice connectors, or solder, & heat shrink for connecting wires to your vehicle harness
- 5/32" drill bit
- Your choice of wire coverings for neatly organizing or bundling wires.
- Zip ties (small or medium) for neatly organizing or bundling wires.
- Basic hand tools
- Wire diagram for your vehicle
- 5A fuse & fuse holder
- Soldering iron, solder, various sizes of heat shrink tubing



### **Step 1:**

Lay out the harness and familiarize yourself with it. You will notice not all of the terminals for the speedometer and tachometer connectors are inserted. This is due to the different configurations of speedometer & tachometer terminal arrangements. You will also find a separate black wire harness which is intended for lighting ground for the 4 smaller gauges. Of the main wire harness, you will notice there are two halves to this harness. We will call those the vehicle side, and the gauges side. You will also find included a small supply of wire terminals which can be used as needed during the installation.

### **Step 2:**

We recommend starting with the vehicle side of the harness (the main harness half without gauge connectors). This will get permanently wired to your vehicle. This will require some basic knowledge of automotive electrical, and in some cases a vehicle specific wiring diagram, or the ability to test circuits to verify proper hook ups. You will find the following wire colors:

**Gray:** Dash Lights. Connect to factory dash lighting wire. If unavailable, you may then connect to a factory-style head light switch that has an internal dimming circuit for dash lights, or a separate dash light dimmer. Look for a 12V power source that turns on and off with the parking lights and or head lights, but also dims (voltage decreases) as you adjust your headlight dimmer. A test light works well for checking this.

**Pink (short):** 12v, key on power. Connect to factory gauges power only if it is 12v. This power should turn on and off with the ignition switch. If there is no factory wire to use, you may either find an ignition power from the fuse box, or from the ignition switch. This should be protected with a 5A fuse.

**Red:** Hi Beam indicator. Connect to factory hi beam indicator wire or to hi beam switch. This circuit will be powered only when headlights are on, and high beams are on.

**Black:** Engine or chassis ground.

**Orange:** Left turn indicator. Connect to factory left turn indicator wire. You may test for this with a test light, with the key on, with left turn signal on and look for a wire that flashes your test light with the turn signals.

**Tan:** This is intended to be used with an existing brake warning light indicator, generally operated off of the brake pressure switch in the brake proportioning valve.

**White/w black stripe:** Right turn indicator. Connect to factory right turn indicator wire. You may test for this with a test light, with the key on, with right turn signal on and look for a wire that flashes your test light with the turn signals.

**Pink (long):** 12v key on power. This is intended for applications where you might be using a 3-wire vehicle speed sensor that requires power. You should find that this wire is powered any time that the previous pink wire is powered. You may also use this to power a GPS interface module, or some other accessory if desired, as long as it fits within the recommended fuse requirements.

**Green:** Temperature sender wire. Connect this to the Auto Meter temperature sender.

**Purple:** Speed signal. Connect this to the signal wire at your speed sender/sensor. If you are using a computer (ECM, PCM, ECU, etc), you may connect this to the factory speed signal wire at the computer instead of the speed sensor if it is equipped. Consult a diagram for your computer to verify.

**Blue:** Oil PSI sender wire. Connect this to the Auto Meter oil pressure sender.

**White:** Tachometer signal wire. Where you connect this will depend on what ignition system you have. If your engine is distributor equipped, with no ignition box, you may then connect to the negative side of the ignition coil. If you are using an after market ignition box, you will connect the white wire to the dedicated tachometer signal output wire, NOT to the ignition coil. If your application has no distributor, or ignition box and is using coil packs you may have an available tachometer signal at your computer.

**Yellow:** This is used only if you have a speed sensor/sender that requires a supplied ground. If you have a speed sensor that is already existing/functioning that is already grounded or is grounded by a computer, then this wire is not needed. If you need to supply ground to your speed sender/sensor, then connect this yellow wire to the ground wire of your speed sender/sensor.

**Dark Brown:** Fuel sender wire. Connect to the fuel sender.

**Step 3:** If you are using a removable gauge panel, now is a good time to determine where you are going to install each gauge and indicator light, and install them into the panel in preparation of wiring. The supplied indicator light simply presses into a 5/32" hole.

**Step 4:** Now that you have wired in your vehicle side of the harness, lets start on the gauges side of the harness. This is generally best done (when there is a removable gauge panel) on a clean work bench or table with the gauges in the panel, and with face down. If this an application where there is no removable panel, you may start by routing the gauges side of the harness from under the dash, and each section of harness hanging out of the appropriate gauge hole. For example, route the section of harness for the oil pressure gauge out the hole where you will install the oil pressure gauge. And so on..

- 3-terminal Gauge connector with only black & pink wire will plug onto the volt meter.
- 3-terminal Gauge connector with brown, pink, and black wires will plug onto fuel level gauge.
- 3-terminal Gauge connector with blue, pink, and black wires will plug onto oil pressure gauge.
- 3-terminal Gauge connector with green, pink, and black wires will plug onto water temperature gauge.
- 8-terminal gauge connector with pink & white wires already inserted, and with loose gray & black wires are for tachometer, but do not plug the connector in yet until you identify where to insert the two loose wires based on the tachometer that you have. See images below for examples.
- 8-terminal gauge connector with pink & purple wires inserted, and with loose gray & black wires are for the speedometer, but do not plug the connector in yet until you identify where to insert the two loose wires based on the speedometer that you have. See images below for examples.

Electric Speedo with lower row terminals



Electric Speedo with upper row terminals



### Electric Speedo with wheel odometer & cal button



Contact Auto Meter Tech Support for the proper terminals for your calibration button if you have this design.

### GPS Speedo



You may remove or simply not connect the purple wire when using a GPS Speedometer. Electric Speedometers that use an interface module still require the purple wire.

### Tachometer with lower row terminals



At this point you should have the following wires left over. Here is where they go. We will address the existing gray wires last.

**\*\*Note:** The supplied red butt connectors are intended to be used with the LED indicator connections. Or you may choose to solder and heat shrink these connections.

- **Yellow:** This is used only if you have a speed sensor/sender that requires a supplied ground. If you have a speed sensor that is already existing/functioning that is already grounded or is grounded by a computer, then this wire is not needed. If you need to supply ground to your speed sender/sensor, then connect this yellow wire to a suitable ground.
- **Pink:** You may connect this to the red wire of the amber brake warning LED, or you may use this to direct power to a GPS interface module.
- **Tan:** This is only used if you are installing a brake warning light. Connect to the black wire of the red brake warning LED.
- **Orange:** Connect to the left turn indicator LED red wire.
- **White/black trace:** Connect to the right turn indicator LED red wire.
- **Red:** Connect to the hi-beam indicator red wire.
- **Black (x3):** Connect one to the left turn indicator black wire, one to the right turn indicator black wire, and one to the hi-beam indicator black wire.

**Step 5:** Connection of the gray wires will depend on the gauge type that you have. If you are using Auto Meter gauges with factory equipped LED through the dial lighting, then you can simply plug each of the gray female terminals into each of the corresponding gauge lighting 12V terminals (see image for LED lighting).

If you are using Auto Meter gauges that use a twist in light socket, you will then cut the white wire on the light socket to your desired length and crimp on one of the supplied male terminals. This will now plug into the female terminal on the gray wires (see light socket wiring image).

**Step 6:** Installing lighting ground harness (separate black harness). If your gauges are factory LED through the dial lit, plug each of the black wire female terminals into each of the corresponding gauges lighting ground terminals See image for LED lighting).

If you are using Auto Meter gauges that use a twist in light socket, you will then cut the black wire on the light socket to your desired length and crimp on one of the supplied male terminals. This will now plug into the female terminal on the black wires (see light socket wiring image).

The black wire harness has a male/female connector that allow for you to unplug a single wire in the even that you need to remove your dash harness. Connect the other end of the single black wire with the factory crimped ring terminal to a good vehicle ground.



LED Lighting



Light Socket Wiring

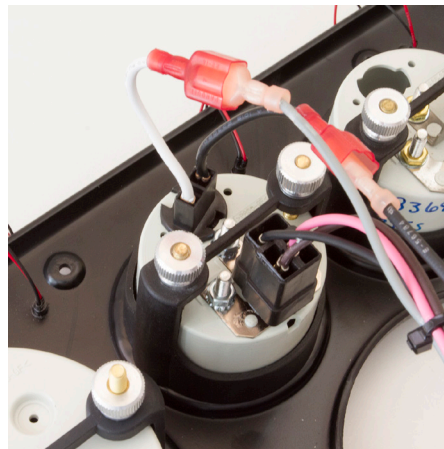

View of wire harnesses installed, connected to gauges.

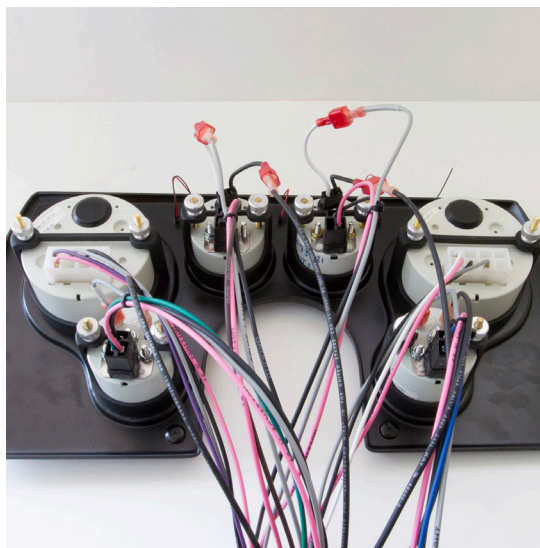

**Step 6:** Plug the gauge harness into the vehicle harness. Check for any loose wires that are not plugged into anything. Turn power on to the vehicle. Check for turn signal operation. Check for gauge lighting. Check for hi-beam indicator operation. If these all function, you may now start the engine and check for gauge operation. Once everything is confirmed to function, you may now take the time to bundle, cover, separate, or organize your wiring and prepare to finish the installation of the gauge panel. If you do not have a removable gauge panel then you are already finished.

### TROUBLE SHOOTING:

**Gauges do not operate:**

- Use your volt meter and check for power on the pink wire at any of the affected gauges. Check for 12v or higher.
- If no power, check the fuse(s) related to the pink wire wherever you chose to get power from.
- If no power, check to make sure the main harness, 15 pin connector is fully seated, plugged into each other.
- If there is power, and all gauges are dead, check the location of your black gauges ground wire in the main harness. When in question, we recommend engine ground.
- If only one gauge, or a couple random gauges not functioning, check for loose or missing meter nuts on the back of these gauges. These are the nuts that secure the male spade terminals to the back of the gauge.(See picture at the end of this section)
- If only one gauge, or a couple random gauges not functioning, check to make sure the gauge connectors are plugged into the affected gauge(s).

**Gauge lights do not operate, but gauge operation is fine:**

- Use your volt meter to verify power on any one of the gray wires at the gauges is present when the lights are turned on.
- If no power, check factory (or after market) dash lights fuse.
- If no power, and fuse is fine, check where you are getting your dash lights power from.
- If there is power to the gray wires of the affected gauge, then check where you are grounding the black gauge lighting ground harness.

**One or more of the gauges reads incorrect, or erroneous readings:**

- Check to make sure the correct gauge connector is plugged into the correct gauge. In other words, the temp gauge harness with the green wire is plugged into the water temp gauge, etc..
- Verify that you have installed the proper sender for the gauge involved. Did you install an Auto Meter sender for temperature and oil pressure?
- Oil pressure and water temp gauge peg or read high on power up. See previous step. Also, check meter nuts (see image at the end of the section) for presence and tightness.
- If this is a fuel level gauge, verify that the proper gauge model number was ordered for the sender that is being used. Not all fuel senders and fuel gauges are compatible.

- Volt meter pegs. Make sure that if your volt meter has an “S” terminal, that there is nothing plugged into the “S” terminal. There should be no wire in the cavity of the gauge connector at the volt meter “S” terminal.

**Speedometer does not function:**

- If the speedometer performs half sweep on power up, and LCD display for odometer illuminates, then check for proper hook up of the speed sender.
- If no half sweep, or LCD display does not turn on, then check for power on the pink wire. Next check for proper pin out regarding the black wire (see step 4 of the instructions).
- If your speed sender is an Auto Meter speed sender, or another after market that is gear driven, you may check for operation by turning power on, then spinning the speed sender with a drill to see if speedometer functions.
- If this is an Auto Meter 3-wire speed sender, verify power to the red wire at the speed sender (supplied by this harness pink wire). Also verify ground to the black wire of the speed sender (supplied by yellow wire of this harness).
- Make sure yellow wire of this harness on the gauges side of the harness is connected to good ground.

**Gauges function until the lights are turned on, then they go dead:**

- Check/relocate the gauges ground (the black wire from the main harness). When in question, we recommend engine ground.

**Tachometer does not function:**

- Check for power on the pink wire. Next check for proper pin out regarding the black wire (see step 4 of the instructions)
- Check location of where you are getting signal. Follow precautions on tachometer instructions regarding after market ignitions.
- if this is computer generated tachometer signal from a computer, there is the possibility that a tachometer adapter (Auto Meter model 9117), or a pull up resistor may be needed.

**One LED indicator does not function:**

- Carefully check the quality of the crimp if the butt connectors were used. Inspect to make sure the crimp was not over the wire insulation.
- Check to make sure the red and black wires of the affected LED were not switched/hooked up incorrectly.
- Use your test light to make sure you still have power/signal going to the LED when commanded (ex., a flashing test light with turn signals on & flashing, or test light on solid when lights on and hi-beams on).

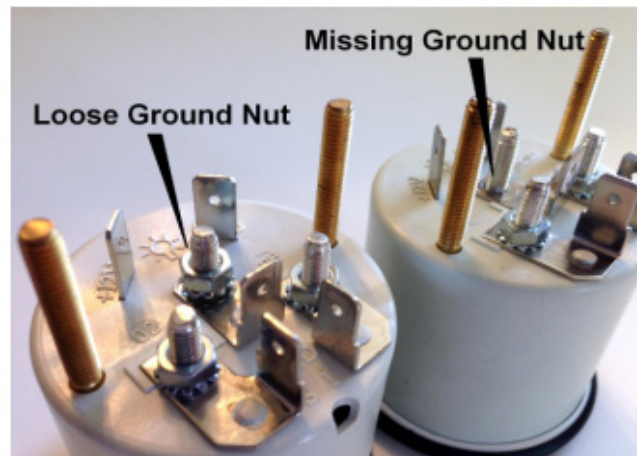

# INSTALLATION INSTRUCTIONS

## SHORT SWEEP ELECTRIC GAUGES



### CAUTION FOR ALL GAUGE INSTALLATION (AMMETERS EXCLUDED)

As a safety precaution, the +12V wire attached to the positive I (+) terminal of the gauge should be fused before connecting to the positive (+) output side of the ignition switch. We recommend using a 3 Amp, automotive type fuse inline between the power supply source and the I (+) terminal on the gauge.

**NOTE:** Some late model vehicles use electronic sensors in their pressure and temperature senders for engine control functions. Before removing the original sender, we recommend that you contact your automotive dealer to be sure no critical functions will be disrupted. With pressure gauges it is beneficial to add a T-fitting to install your new gauge and to keep the warning light operational. This allows you to monitor the pressure and still have a warning light to indicate emergency conditions.

**NOTE::** Disconnect negative (-) battery cable before installation.

**CAUTION:** Do not touch ignition wire to the sender (S) terminal on back of gauge or the sender may be damaged.

## Mounting

These gauges can be mounted in-dash or in Auto Meter mounting solutions (panels, cups, pods, etc.). 2 1/8" diameter gauges mount in 2 1/8" hole, 2 5/8" diameter gauges mount in 2 5/8" hole. Fasten with brackets supplied as shown. (Hookup wire is required.) To assure proper functioning of this instrument, please read instructions thoroughly before installing.

### Metric Adapters

If this product is to be installed on a vehicle requiring metric fittings, please contact you local Auto Meter dealer to purchase metric adapters.

FRONT MOUNTING  
(BOTTOM VIEW)

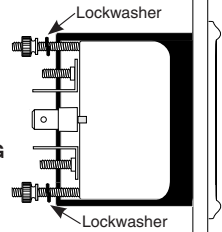

## Wiring

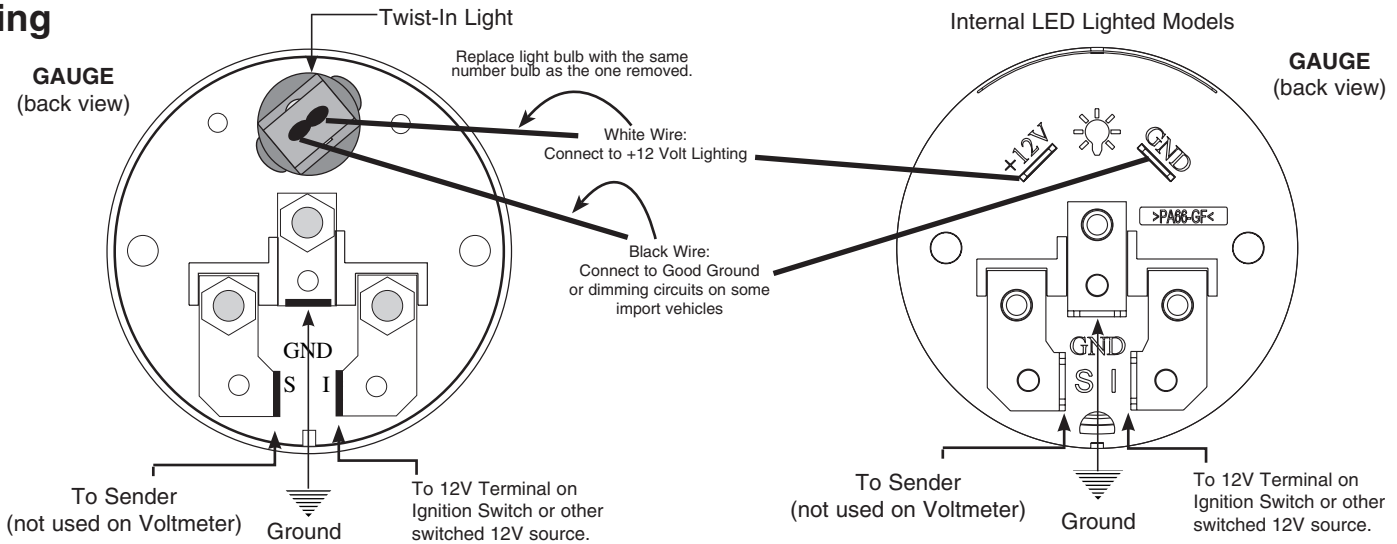

## Temperature Gauges

- Install temperature sender.
  - Water Temp:** Install temperature sender (included). Purchase of additional fittings such as metric or hose adapters may be required.
  - Oil & Trans. Temp:** Hole may have to be drilled and adapter nut (included) welded or brazed in pan. Be sure there is adequate internal clearance for nut and sender. Sender should automatically be grounded when installed. If not, proper ground connections should be made. May use #2260 weld on bung on steel pans (not included).
  - Cylinder Head Temp:** Head must be drilled and tapped for 1/8" NPT hole. Sender should be grounded automatically when installed. If not, proper ground connections should be made. Be sure not to drill all the way through.
  - Diff. Temp:** Install temperature sender in 1/8" NPT sender port on cover if available. If cover does not have a port, remove cover and drill and tap a 1/8" NPT hole or, drill and weld, or braze, adapter nut (included) in cover. Proper ground connections should be made by running ground wire from bolt in cover to chassis, being sure to leave enough slack in wire for suspension travel.
- Route 18-gage wire through firewall. If a new hole is drilled in the firewall a grommet is recommended. Connect one end to terminal post on temperature sender, and opposite end to sender (S) terminal on back of gauge.
- Route 18-gage wire from center terminal GND (-) on back of gauge to good ground near sender.
- Connect wire from ignition switch to ignition (I) terminal on back of gauge.
- Reconnect negative (-) battery cable.

USE TEFLON SEALING COMPOUND ON PIPE THREADS

TEMPERATURE SENDER

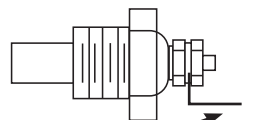

To S-Terminal on gauge  
Note: Sender grounds through threads

## Pressure Gauges

- Install sender into pressure port of appropriate type. **If unit is to be installed on a high vibration application such as a full race engine or engine capable of high RPM, it is strongly recommended that the sender be remote mounted to either the fenderwell or firewall, to insulate from vibration. Failure to remote-locate pressure senders on such an application could result in gauge failure and potential damage to vehicle and/or operator injury.** Braided stainless steel lines are sold separately by Auto Meter, and can be used to accomplish this. Sender features 1/8" NPT male fitting and comes with 1/4" NPT adapter. Sender should automatically be grounded when installed. If not, or if remote relocation of sender is required, a ground connection to sender "body" may need to be made.
- Route 18-gage wire through firewall. If a new hole is drilled in the firewall a grommet is recommended. Connect one end to terminal post on pressure sender, and opposite end to sender (S) terminal on back of gauge.
- Connect wire from center terminal GND (-) on back of gauge to good engine ground near sender.
- Connect wire from ignition switch to ignition (I) terminal on back of gauge.
- Reconnect negative (-) battery cable.

USE TEFLON SEALING COMPOUND ON PIPE THREADS

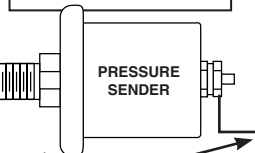

Note: Sender grounds through threads  
To S-Terminal on gauge

# Ammeter

Read **before** installing: **Must be installed by experienced technician.**

## WARNING

Have your maximum alternator output tested. Choice of improper ammeter rating and/or wire size, and any loose connections can cause dangerous overheating, which could lead to a fire in the vehicle. Ammeter and wire should have a capacity of at least 10 amps more than your vehicle's maximum alternator output.

- 10-gage wire or larger must be used.
- IMPORTANT:** Verify that base nuts on both meter terminals are tight. Tighten base nuts prior to installing terminal lugs and wires. Connect ammeter as shown.

### CAUTION:

**DO NOT CONNECT THE AMMETER ACROSS THE BATTERY.**

- IMPORTANT:** Terminal lugs must be BOTH crimped and soldered to wire; star lockwashers must be used on both sides of terminal lugs.
- Tighten terminal nuts to compress star lockwashers into terminal lugs.
- Verify that **none** of the ammeter connections are to ground.
- Reconnect negative (-) battery cable.
- Leaving engine **off**, turn on lights. Indicator should read negative (-). If it reads positive (+), disconnect neg. battery terminal and reverse the wires on back of meter, then reconnect neg. battery terminal. **Before** starting engine, double check that all connections are tight. After starting engine, check wiring connections for hot spots. Be prepared to shut engine off **immediately** if hot spots are detected.

# Wiring

Example wiring of a typical Ammeter installation. Consult vehicle Mfr. for specific wiring details and safety considerations.

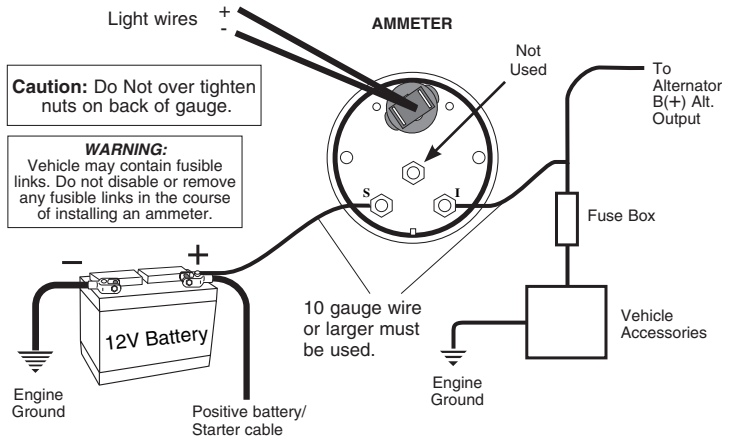

# Fuel Level

Contact Auto Meter service if help is needed in determining your sender resistance.

**Note:** Before beginning installation, check to make sure stated resistance range for the gauge matches your sending unit value for proper operation. The chart below may be helpful in determining what resistance range of gauge to use.

	SENDER RESISTANCE (OHMS)	
	EMPTY	FULL
For most GM vehicles to 1997	0	90
For most Ford and Chrysler vehicles	73	8-12
Use 3262 Fuel level sender	240	33
For most GM vehicles before 1965	0	30
Most '89 and newer Fords	16	158

- Gauge connects to fuel sender on fuel tank. Existing wires may be used, or route proper length of 18 gage, wire from fuel tank to gauge. If a new hole is drilled in the firewall a grommet is recommended. Connect one end to terminal post on fuel level sender and the opposite end to the sender (S) terminal spade on back of gauge.
- Connect ground wire from ground post on gauge to suitable chassis ground.
- Connect wire from ignition switch to the positive I (+) terminal on the back of gauge. See figure right.
- Reconnect negative (-) battery cable.
- Be sure that body or mounting flange of sender is grounded to suitable chassis ground.

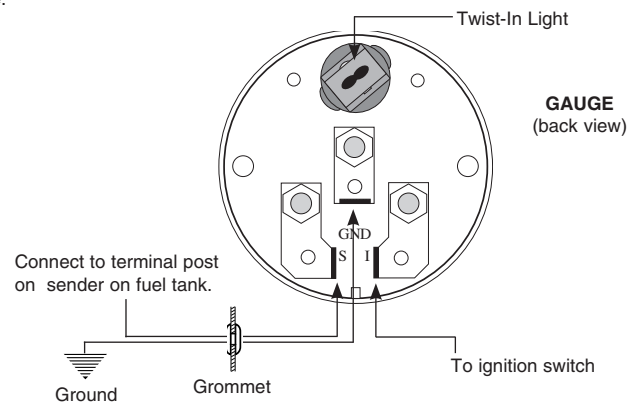

**NOTE:** Failure to ground sender as in step 5 may result in inoperable gauge.

# Voltmeter

- Using 18 gage wire, route one length through firewall. If a new hole is drilled in the firewall a grommet is recommended. Attach one end to the negative GND (-) spade terminal on back of gauge, and the opposite end to a good engine ground. See illustration at right.
- Attach one length of wire to the positive I (+) terminal on back of gauge and opposite end to 12V terminal on ignition switch or other 12V switched power source.
- Reconnect negative (-) battery cable.

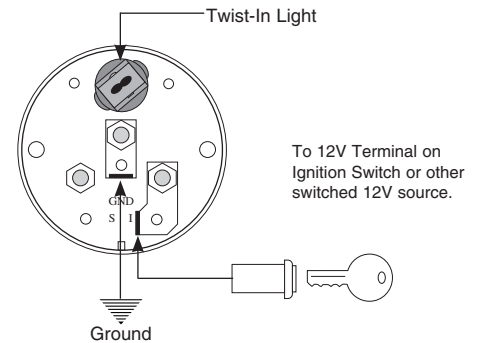



# INSTALLATION INSTRUCTIONS

## IN-DASH ELECTRIC TACHOMETER

For Use on Early Model & Most Electronic Ignitions



### Calibration

**IMPORTANT:** This tachometer is factory calibrated to operate on 8 cylinder engines. For 4 or 6 cylinder engines, it is necessary to make the proper adjustments to adapt this tachometer to your cylinder range.

Locate the access hole on the back of the tachometer. Move each of the two switches to the proper cylinder selection according to the diagram illustration on the right. Use a small screwdriver or an unwound paper clip to change the switch settings.

**NOTE:** This tachometer has an air core meter. With power off, it is normal for the pointer to leave zero. When power is applied, the pointer will move to the correct position.

**Figure A.**

- 8 CYL. (4 pulse)- Both switches up.
- 6 CYL. (3 pulse)- Switch One up, Switch Two down.
- 4 CYL. (2 pulse)- Switch One down, Switch Two up.
- 4 CYL. (1 pulse)- Both switches down.

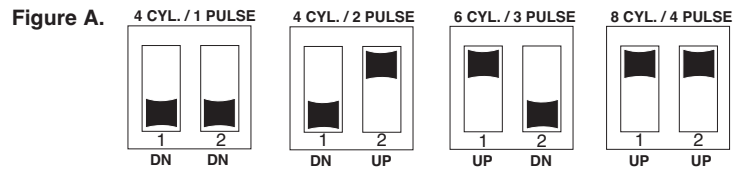

(Angle view through access hole)

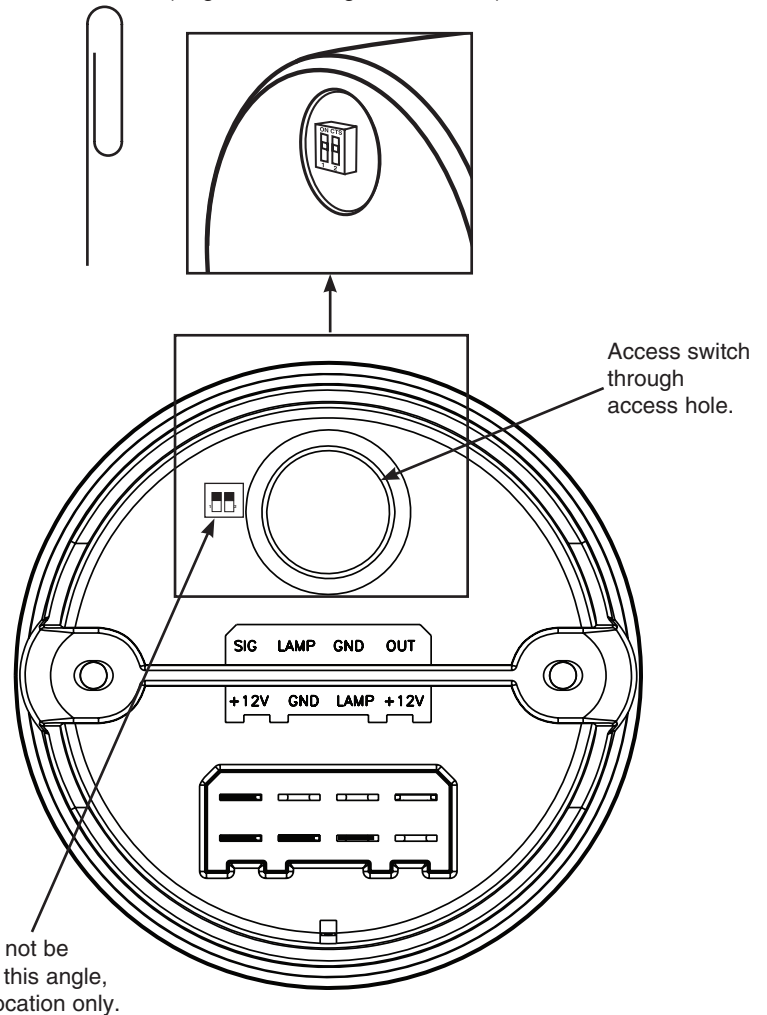

3<sup>3</sup>/<sub>8</sub>" SIZE SHOWN

### Lens Cleaning

To prevent scratching the lens when cleaning, use a mild, soapy solution to clean. Wipe lightly with a soft cloth.



### Note:

This tachometer operates on most early model ignitions, factory electronic and high performance electronic racing ignitions.



# Mounting

1. Mount the 3 $\frac{3}{8}$ " tachometer in a 3 $\frac{3}{8}$ " dia. hole and a 5" tachometer in a 4-5/8" dia. hole in the dashboard.  
(Be careful not to cut the hole too large.)
2. Cut a  $\frac{3}{8}$ " dia. hole in the firewall for the tachometer wires. Place a rubber grommet in the hole and route the connector wires through the grommet to the engine compartment.
3. Connect the tachometer wires as shown in the Wiring Section.
4. Secure the tachometer to the dashboard using the provided bracket & hardware.

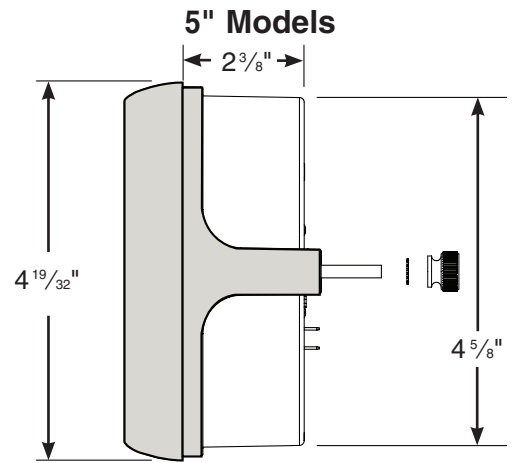
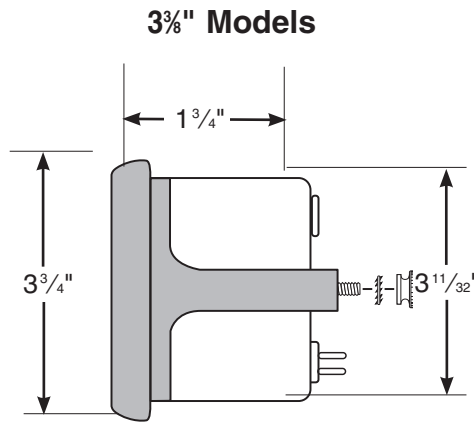

# WIRING

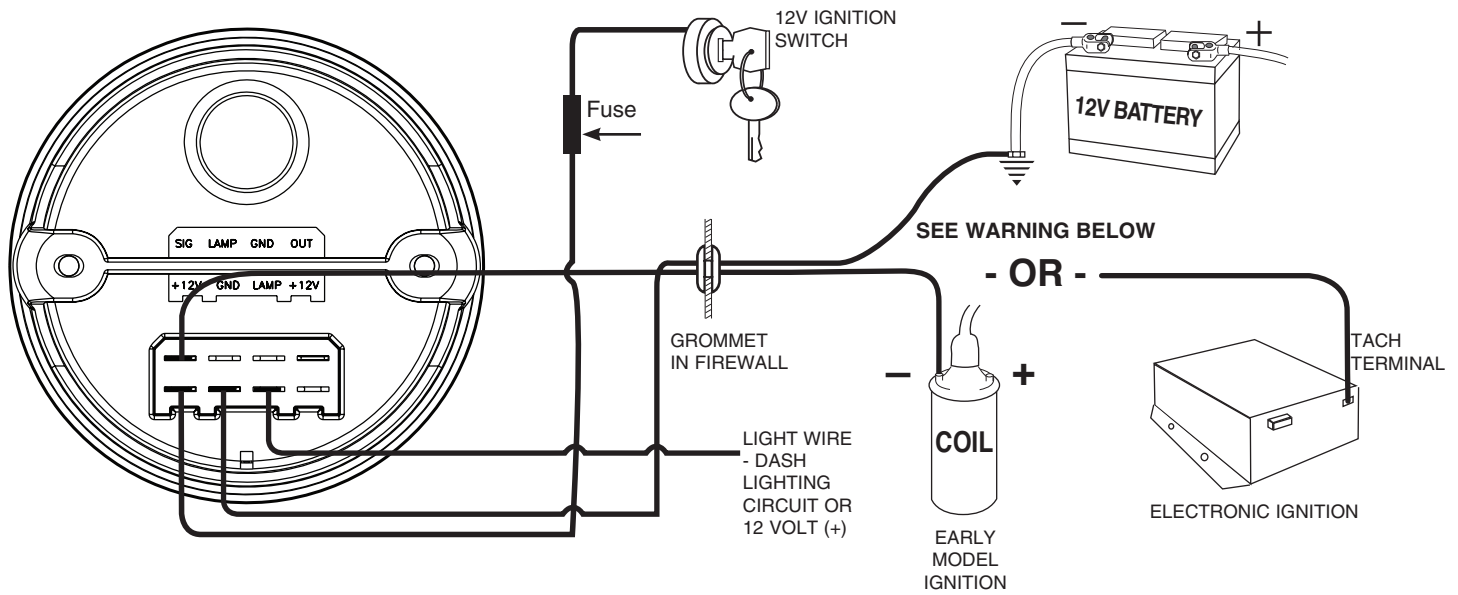

**WARNING**

Warranty will be void if connected to coil when using an aftermarket ignition box such as, but not limited to products from the following manufacturers: MSD, Crane, Jacobs, Mallory, Holley, Etc.. Prior to installation of your tachometer, check with the ignition box manufacturer for recommended tachometer signal location.

**CAUTION!**

As a safety precaution, the +12 V terminal of this product should be fused before connecting it to the 12V ignition switch. We recommend using a 3 Amp, automotive fuse or equivalent to help protect this product.

## SERVICE

For service send your product to Auto Meter in a well packed shipping carton. Please include a note explaining what the problem is along with your phone number. Please specify when you need this product back. If you are sending product back for warranty adjustment, you must include a copy (or original) of your sales receipt from the place of purchase.