

INSTALLATION INSTRUCTIONS GPS ELECTRIC SPEEDOMETER (LED LIT MODELS)

2650-1823-00



Mounting

1. Mount a 3³/₈" speedometer in a 3³/₈" dia. hole and a 5" speedometer in a 4⁵/₈" dia. hole. Be careful not to cut the hole too large.
2. Cut a 3³/₈" dia. hole in the firewall for the speedometer wires. Place a rubber grommet in the hole and route the wires through the grommet to the engine compartment.
3. Connect the speedometer wires as shown in the wiring sections.
4. Secure the speedometer to the dashboard using the provided bracket and hardware.

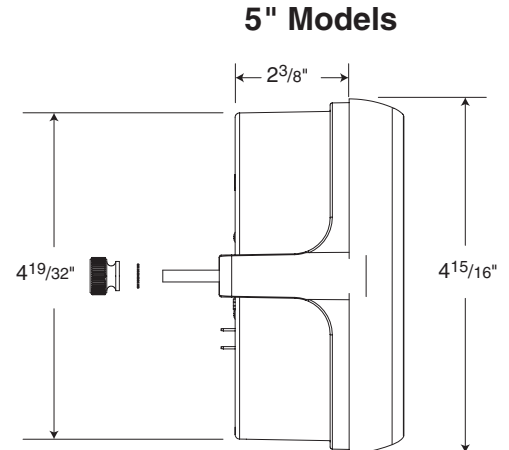
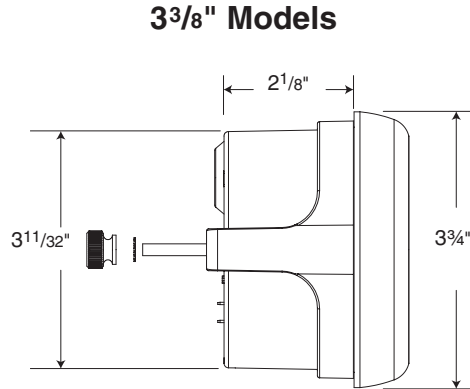

Wiring

Connect the GPS speedo as shown below. Connect the external GPS antenna (supplied with unit) to the gold SMA connector on the back of the unit.

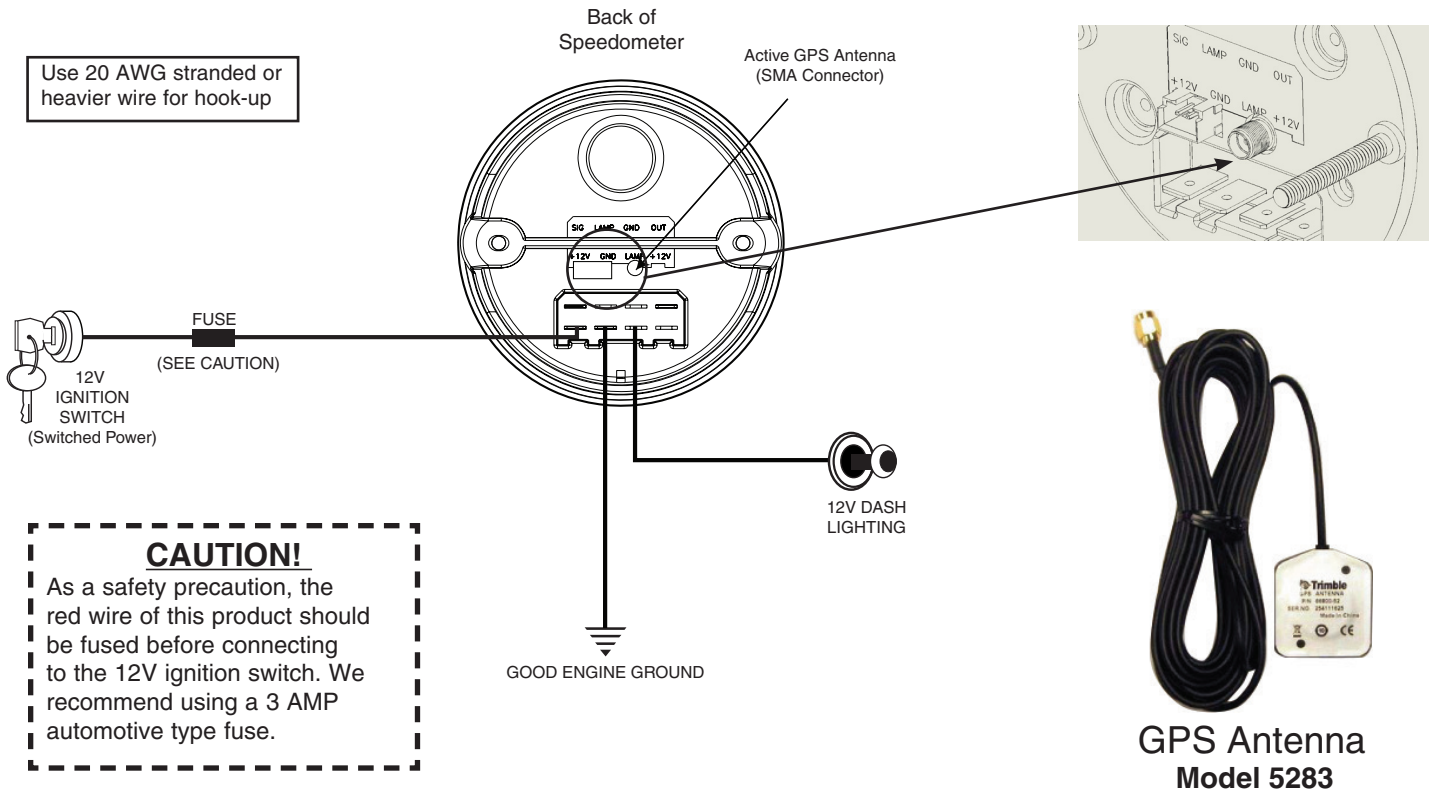

Powering Speedometer

Once the speedometer is mounted and wired into the vehicle, the speedometer should be tested to verify that the electrical connections are working properly. First, apply power to the speedometer. The LED display will show "AMP GPS", then the firmware version number. *If an optional external NEMA data source is connected, a menu item will be displayed followed by the data for this menu item. If only the external antenna is connected, the readout will display "ACQUIRING SIGNAL". Once a valid position is determined the display will read "LOCKED" and go to the last selected menu item. External data will take precedence over the antenna input.

*This speedometer can be used with external NEMA data source using optional Auto Meter 5214 wire harness pigtail.

Time Set Up

The time can only be set when there is a valid position, this will be indicated with colons between the time digits.

To set the current time, while in the time mode hold down the (left) menu button and press the right button until the correct hour is displayed, then release the menu button. Note- When setting the time a 24 hour clock will always be used. During operation, you can always switch between a 12 hour and 24 hour clock by tapping the right button while in Time Mode.

Operation

There are seventeen menu items to choose from. Press the left button to cycle between the different menu items.

- Time - will display the current time.
- Heading - will display your current heading when moving as a compass direction and heading in degrees.
- Peak Speed – will display your peak speed. This value can be cleared by pressing and releasing the right button.
- Speed - Displays current speed.
- Trip – will display the number of miles traveled since it was reset. This value can be cleared by pressing and releasing the right button.
- Trip Time - Shows the elapsed time in hours, minutes and seconds since the speedometer was turned on.
- Odometer – Will display the miles traveled since installed. This value can not be reset.
- Location – will display your current latitude and longitude.
- Hours – will show engine hours since installed. This value can not be reset.
- Display – will control the brightness of the display. There are 6 levels of brightness. After entering the display mode the current brightness level will be displayed. Pressing the right button will advance the current brightness level, returning to the lowest level after level 6. Pressing the menu button or not pressing any button for 4 seconds will return the display to the time mode.
- Pitch – will show the effective up and down pitch of the vehicle, in degrees. Upward is positive.
- Roll – will show the effective clockwise and counter clockwise roll of the vehicle, in degrees. Clockwise is positive.
- 0 to 60 – will display the time in seconds it takes to reach 60 MPH from a dead stop. With the vehicle stopped, press the right button. This will clear the previous time and reset the gauge for the next run. The display will show "Ready". Accelerate to more than 60 MPH .
- 60 to 0 – Measures distance in feet it takes to reach a dead stop from 60 MPH. Press the right button. This will clear the previous time and reset the gauge for the next run. Once the vehicle speed exceeds 65 MPH the display will show "Ready" Brake to a stop.
- Total G's - will show the vector sum of longitude, latitude, and vertical acceleration.
- Long G's - will show the longitude (forward) acceleration.
- Lat G's - will show latitude (left and right) acceleration.

Accelerometer Calibration

This step only needs to be done once, when gauge is installed. The only time you should need to do this step again is if the gauge changes position/angle in the vehicle. The vehicle must be parked on a flat, level, surface. With power off to the gauge, press and hold the right button. Turn on the power, then release the button. The display will show "Cal Acl?", then "Yes or No?". Press and release the left button. The display will show "Hold", then "Go". Accelerate the vehicle in a straight line. It is not required to have full launch acceleration. Note: Higher acceleration rates will result in a more accurate calibration. The gauge needs to see 2 seconds of continuous straight line acceleration. Once it's gathered what it needs the display will read "Done". You can now stop the vehicle.

Antenna Placement

The antenna can be placed inside or outside of the vehicle. The antenna is waterproof and can be painted. Common mounting places are the roof, top of the dashboard, and top of rear package tray (interior of rear window). If using any other GPS device, keep antennas at opposite ends of the vehicle for best results. Closely mounted antennas can increase the time it takes to acquire a signal. (Service replacement antenna model #5283)