

Wiring Installation Instructions for : RPM Tachometer 2 1/16" Controller

PACKAGE CONTAINS:

- Tachometer Gauge 2 1/16" INCH
- Wiring Harness
- Mounting Cup (Not required for pod installation)
- (2) Neoprene EDPM Grommets

SPEK™ MONITOR AND CONTROL PERFORMANCE GAUGE TACHOMETER

FEATURES:

SPEK PERFORMANCE GAUGE TACHOMETER FEATURES:

- INTELLIGENT ELECTRICAL GAUGES.
- GAUGES ARE PROGRAMMED THROUGH COMMAND KEYS ON FACEPLATE.
- STEPPER MOTOR DRIVES THE GAUGE POINTER OVER A 280 DEGREE SWEEP.
- WIDE-ANGLE-DIAL™ HAS A 15% LARGER VIEWING AREA ON A 2 1/16" GAUGE.
- PROGRAMMABLE 7 COLOR DIAL AND RED POINTER ILLUMINATION.
- OPTIONAL OUTPUT CONTROL MODULE.

INSTALLATION INSTRUCTIONS:

- 1** DISCONNECT NEGATIVE (-) BATTERY TERMINAL.
- 2** VARIOUS MOUNTING SOLUTIONS ARE PRESENTED BY PROPARTS
DASH INSTALLATION: SELECT LOCATION IN THE DASH TO MOUNT GAUGE AND CUT A 2 1/16" HOLE. USE A FILE TO INCREASE THE HOLE SIZE IF REQUIRED. BE SURE THERE IS SUFFICIENT ROOM BEHIND THE HOLE FOR THE METER CASE AND THE CONNECTORS YOU WILL USE.
- 3** IF A SUITABLE HOLE IN THE FIRE WALL IS NOT AVAILABLE, CUT AN 11/16" HOLE.
- 4** TWO GROMMETS MUST BE CUT TO PERMIT INSTALLATION OF WIRING HARNESS. (SEE **DIAGRAM 1**)
- 5** INSTALL THE GROMMET AND MOUNTING CUP ON THE WIRING HARNESS AS SHOWN IN **DIAGRAM 1**. GROMMET IS FOR THE HOLE IN THE FIREWALL.

Wiring Installation Instructions for : RPM Tachometer 2 1/16" Controller

- 6** DO NOT CONNECT WIRING HARNESS TO THE GAUGE UNTIL THE OTHER CONNECTIONS HAVE BEEN MADE AND TESTED.
- 7** CONNECT THE **RED** (+ 12 VOLT SUPPLY) WIRE TO "ON" CIRCUITS THAT GET POWER WHEN THE IGNITION IS TURNED-ON. THIS CIRCUIT MUST BE FUSED BEFORE THE IGNITION SWITCH (1 AMP, 3AG FAST ACTING).
- 8** CONNECT THE **BLACK** WIRE TO A GOOD GROUNDING POINT ON THE CAR'S CHASSIS.
- 9** CONNECT THE **WHITE** WIRE TO THE DIMMER VOLTAGE GOING TO THE DASH LIGHTS. THIS WILL CAUSE THE METER BRIGHTNESS TO TRACK THE BRIGHTNESS OF THE REST OF THE INDICATORS. THIS CIRCUIT MUST PRODUCE 3 TO 12VDC BEFORE THE PPR CAN BE PROGRAMMED.
- 10** CONNECT THE SENSING WIRE TO THE PRIMARY TERMINAL ON THE IGNITION COIL (STANDARD-TYPE COIL) OR TO THE AUXILIARY TERMINAL MEANT FOR THE TACH WIRE (AFTER MARKET, HIGH PERFORMANCE COIL). DO NOT CONNECT TO COIL ON MSD IGNITION. ATTACH ONLY TO TACH TERMINAL.
- 11** PLUG THE WIRING HARNESSES INTO THE GAUGE AND MOUNT IN POD OR DASH.
- 12** FOR DASH INSTALLATION, ATTACH MOUNTING CUP OVER THE BACK OF THE GAUGE AND HAND TIGHTEN. DO NOT OVER TIGHTEN. MOUNT CUP BEFORE INSTALLING GROMMET. FAILURE TO DO SO WILL TWIST WIRES CAUSING A SHORT CIRCUIT.
- 13** POWER UP THE GAUGE AND INSPECT ALL CONNECTIONS. IF GAUGE IS OPERATING NORMALLY, PROCEED TO "PROGRAMMING MANUAL".

Wiring Installation Instructions for : RPM Tachometer 2 1/16" Controller

DIAGRAM 1

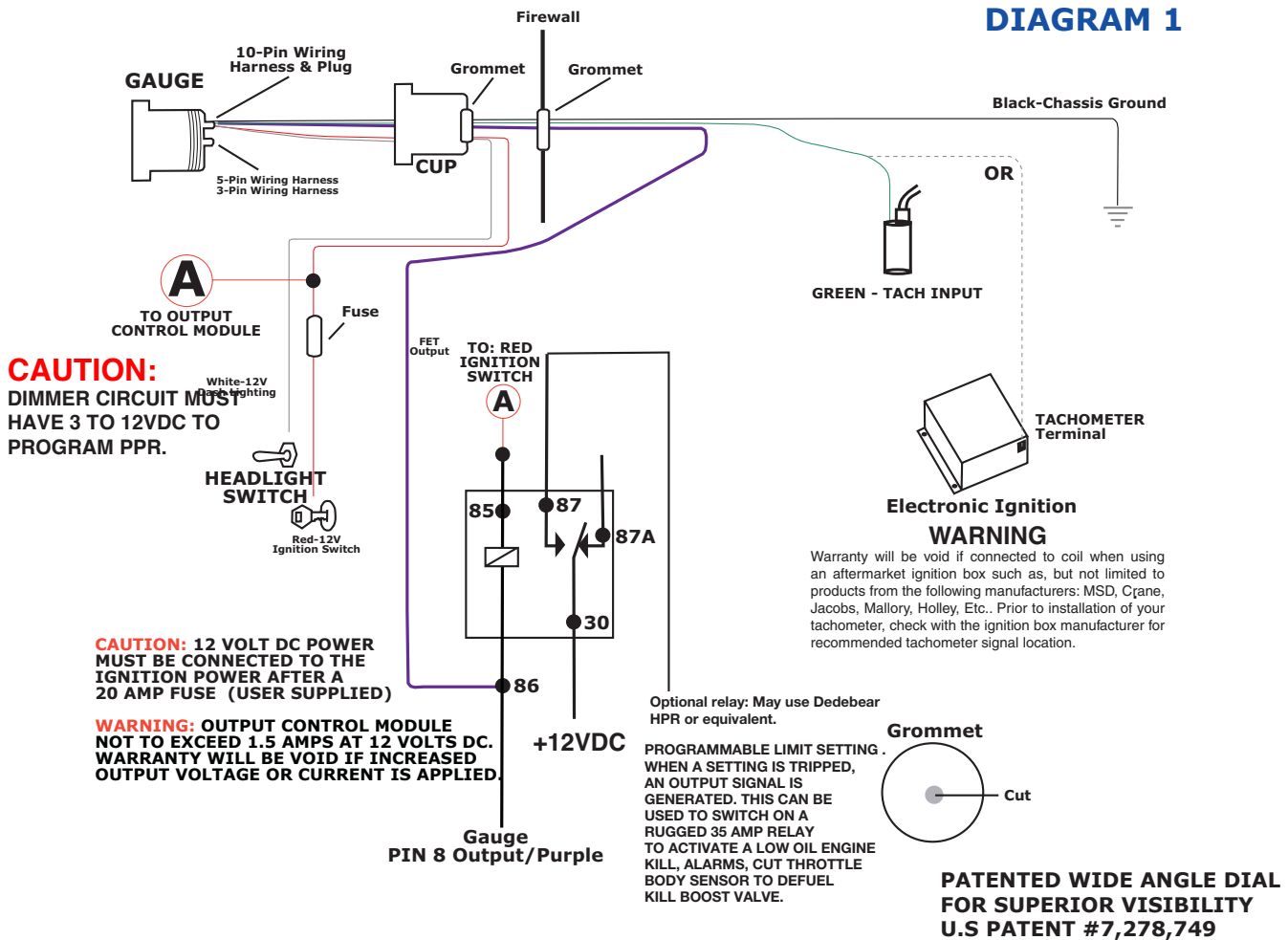
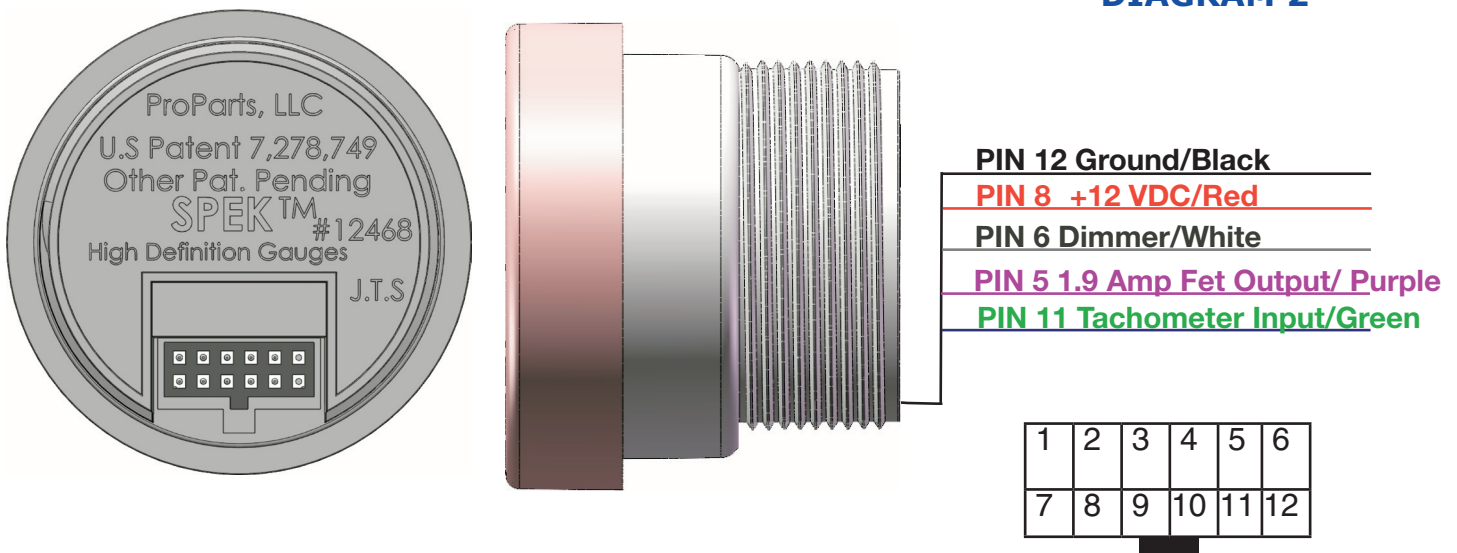

DIAGRAM 2



Wiring Installation Instructions for : RPM Tachometer 2 1/16" Controller

THERE ARE THREE SECTIONS TO THIS MANUAL: WIRING INSTRUCTIONS, PROGRAMMING INSTRUCTIONS AND FLOW CHART PROGRAMMING INSTRUCTIONS. PLEASE READ EACH SECTION CAREFULLY BEFORE ATTEMPTING TO INSTALL OR OPERATE THIS PRODUCT.

WARNING:

- **ALL INSTRUCTIONS IN THIS MANUAL MUST BE FOLLOWED TO INSURE SAFE INSTALLATION AND OPERATION OF THIS PRODUCT.**
- **NEVER DISASSEMBLE MODIFY OR TAMPER WITH THIS PRODUCT. THIS COULD CAUSE DAMAGE AND MAKE THEM UNSAFE TO USE. TAMPERING WITH THE PRODUCT WILL VOID THE LIMITED WARRANTY.**
- **INSTALLATION MUST BE PERFORMED BY AN EXPERIENCED AUTOMOTIVE TECHNICIAN.**
- **INSTALLER MUST USE SAFETY GLASSES.**
- **DISCONNECT THE NEGATIVE BATTERY TERMINAL BEFORE BEGINNING INSTALLATION. PROPARTS LLC IS NOT RESPONSIBLE FOR DAMAGE TO ENGINE, VEHICLE OR UNIT CAUSED BY ELECTRICAL SHORTS.**
- **DURING INSTALLATION, DO NOT INTERFERE WITH ANY EXISTING CONNECTIONS OR WIRES.**
- **ALL ELECTRICAL CONNECTIONS USE SOLDER LESS CONNECTORS AND INSULATE ALL CONNECTIONS WITH ELECTRICAL TAPE.**
- **AVOID WIRING NEAR ENGINE, EXHAUST SYSTEM, TURBINE OR ANY AREA THAT MAY RESULT IN DAMAGE.**
- **DISCONTINUE USE OF THE PRODUCT IF SMOKE OR A STRANGE ODOR IS PRESENT.**

CAUTION

- **PROPARTS LLC IS NOT RESPONSIBLE FOR INCORRECT INSTALLATION OR PROGRAMMING OF SPEK™ GAUGES OR CONTROLLERS.**
- **SPEK™ GAUGES AND CONTROLLERS ARE DESIGNED FOR 12V DC ELECTRICAL SYSTEMS WITH A NEGATIVE GROUND.**
- **DO NOT ADJUST THE GAUGES OR GAUGE PROGRAM WHILE DRIVING**
- **OBEY ALL RULES AND REGULATIONS OF HIGHWAY AND STREET DRIVING.**
- **INSTALL SENSOR AND WIRE AWAY FROM HIGH HEAT AND / OR VIBRATION AREAS.**
- **USE CARE WHEN CONNECTING OR DISCONNECTING THE WIRING HARNESS. PULL OUT EACH CONNECTOR WHILE PRESSING THE LOCK OF THE CONNECTOR FIRMLY.**
- **IF THE BATTERY TERMINAL IS DISCONNECTED, THE AUDIO, CLOCK AND OTHER MEMORY DATA MAY BE LOST. THE NECESSARY DATA WILL HAVE TO BE RESET AFTER INSTALLATION.**

Programming Instructions for : RPM Tachometer 2 1/16" Controller

SPEK™ MONITOR AND CONTROL PERFORMANCE GAUGE TACHOMETER

Refer to the "Flow Chart Programming Instructions" while reviewing this guide.

Gauge is field programmable by the operator while installed in the vehicle. This programming is accessed by pressing the control buttons located on the face or the meter dial, ONE AT A TIME. The "Down" and "Up" buttons move the pointer to a desired setting or controls the faceplate illumination. The center "Mode" button will save the setting you choose and proceed to the next level. Pressing the "Mode" and "Up" or "Mode" and "Down" buttons simultaneously and holding them for 5 seconds in any level will shift you to the Submenu.



MAIN MENU	SUBMENU
NORMAL OPERATION	OPTION:SELECT PPR
PEAK PLAYBACK	OPTION:RESTORE FACTORY DEFAULT
HIGH RED-LINE SETTING	
LOW THRESHOLD SETTING	
COLOR SCHEME	OPTION: DEMO MODE
DIAL BRIGHTNESS	OPTION: POINTER BRIGHTNESS

U. S. PATENTS 7,612,660 AND 7,278,749 ADDITIONAL PATENTS PENDING.

Programming Instructions for : RPM Tachometer 2 1/16" Controller

PROGRAMMING STARTS IN MAIN MENU

PRESS PROGRAM BUTTON ONE (1) AT A TIME IN THE MAIN MENU MODE.

1 NORMAL OPERATION:

On power up, the meter usually starts in **NORMAL** operating mode. The Tachometer will read engine's RPM. Press the center "mode" button to advance to **2 PEAK PLAYBACK**

2 PEAK PLAYBACK:

Reads the highest value displayed on the meter since the last time the "Peak" value was displayed. Pressing the "Down" or "Up" control button will control the gauge dial illumination. Press the center "Mode" button to advance to **3 HIGH RACING RED-LINE SETTING**

3 HIGH RACING RED-LINE SETTING:

Sets the point at which "HIGH" warning RED-LINE is reached for that specific gauge. The "Down" and "Up" buttons will move the dial pointer to select "Maximum RED-LINE". During normal operation the gauge constantly monitors the sensor value and compares it to the "HIGH" RED-LINE. If the threshold is exceeded, the red "HI" indicator is turned on and an output signal generated. Press the center "Mode" button to save the setting and advance to **4 LOW RACING YELLOW-LINE SETTING**

4 LOW RACING YELLOW-LINE SETTING:

Set the Minimum RED-LINE: Sets the point at which "LOW" warning threshold is reached for that specific gauge. The "Down" and "Up" buttons will move the dial pointer to select the **LOW RACING YELLOW-LINE SETTING**. During normal operation the gauge constantly monitors the sensor value and compares it to the "LOW" threshold. If the sensor value drops below the threshold, the yellow "LOW" indicator is turned on and an output signal generated. Press the center "Mode" button save the setting and advance to **5 COLOR SCHEME**

5 COLOR SCHEME:

Set Faceplate Color Scheme: Operator can select the color of the gauge dial illumination. Each time you press the "Down" control button you scroll through dial color selection until the dial light goes off. Then press the "Up" button to reverse the scroll. Select your dial color illumination by pressing the center "Mode" button to save the setting and advance to **NORMAL OPERATION**.

6 DIAL BRIGHTNESS:

Adjust the dial brightness for day or evening driving conditions The RIGHT and LEFT command buttons will dim or brighten the faceplate illumination. Press the center "Mode" button to save the setting and advance you to **NORMAL OPERATION**

Programming Instructions for : RPM Tachometer 2 1/16" Controller

SUBMENU

SUBMENU IS ACCESSED THROUGH THE MAIN MENU. FIRST GO TO THE APPROPRIATE LEVEL OF THE MAIN MENU AND THEN FOLLOW THE INSTRUCTIONS IN THE PROGRAMMING FLOW DIAGRAM TO ENTER THE SUBMENU. PRESS THE "MODE" AND "UP" OR "MODE" AND "DOWN" BUTTONS SIMULTANEOUSLY FOR 5 SECONDS TO ENTER THE SUBMENU AND ONE BUTTON AT A TIME WHILE IN THAT SUBMENU.

OPTION:SELECT PPR: (Pulses Per Revolution) Select the PPR value by pressing "Down or "Up" button to move dial pointer to corresponding RPM. For additional information see the Tachometer Sense Line Attachment and Meter Setting section on page 4.

OPTION:RESTORE FACTORY DEFAULT: TO RESTORE FACTORY DEFAULTS, PRESS THE "MODE" BUTTON ONCE TO ENTER THE **PEAK PLAYBACK**. THEN PRESS AND HOLD THE "MODE" AND "UP" BUTTONS FOR FIVE SECONDS. Activation of the Default will erase all field calibration setup settings that are programmed. Factory calibrations will not be affected.

OPTION A:DEMO MODE: Displays the features of the meter. The pointer goes up and down the scale, the dial colors change and the **HI**, **LOW** and **PEAK** warning indicators light. The Demo mode does not time out. If the gauge is turned off in the Demo mode, it will start up in the Demo Mode. Press the "Mode" button to return the gauge to NORMAL operation.

OPTION: POINTER BRIGHTNESS MODE: The "Down" and "Up" buttons adjust the dial pointer brightness to blend in with original manufacturer's gauges and the owner's requirements Press the center MODE button to save the setting and return to **NORMAL OPERATION**

PROGRAMMING INFORMATION:

- TO RESET THE PROGRAM TO NORMAL OPERATION FROM ANY MODE PRESS THE "UP" AND "DOWN" BUTTONS SIMULTANEOUSLY. THIS SOFT RESET CANCELS THE INFORMATION YOU PROGRAMMED IN THAT MODE ONLY AND RETURN YOU TO NORMAL OPERATION.
- THE FACEPLATE WILL "FLASH" WHEN BUTTONS ARE DEPRESSED TO ACKNOWLEDGE COMMANDS.
- PROGRAMMING ERRORS WILL BE SIGNALLED BY FLASHING THE FACEPLATE LIGHTING "**PURPLE**", "**BLUE**", "**GREEN**" THEN "**ORANGE**".
- IF PROGRAMMING IS INACTIVE FOR 60 SECONDS THE MODE WILL TIME OUT AND THE GAUGE WILL RETURN TO NORMAL OPERATION, EXCEPT FOR THE DEMONSTRATION MODE. THE DEMO MODE WILL NOT TIME OUT UNTIL THE CENTER "MODE" BUTTON IS PRESSED IF THE GAUGE IS TURNED OFF IN THE DEMO MODE, IT WILL START UP IN THE DEMO MODE.

Programming Instructions for : RPM Tachometer 2 1/16" Controller

TACHOMETER SENSE LINE ATTACHMENTS AND METER SCALING

GASOLINE ENGINES

The **WHITE/DIMMER** circuit must be installed and supply 3 to 12vdc before the PPR can be programmed

Attach the sensing line to the primary side of a spark coil, and then set the calibration PPR value for your spark configuration, using directions for the CALIBRATION option.

Once upon a time, there was just one configuration: a spark coil, a distributor, and then wires from the distributor cap to the individual sparkplugs. If your car is like this, use the table below:

FOR "CLASSIC" ONE-IGNITION-COIL ENGINES

# PLUG	PULSES PER REVOLUTION (PPR)	METER SETTING
2	1	1000
4	2	2000
6	3	3000
8	4	4000
10	5	5000
12	6	6000

IF YOU HAVE ONE

COIL PER PLUG CONNECT TO ANY SPARK COIL PRIMARY

# PLUG	PULSES PER REVOLUTION (PPR)	METER SETTING
Any	1/2	500

IF YOU HAVE ONE COIL PER TWO PLUGS CONNECT TO ANY SPARK COIL PRIMARY

# PLUG	PULSES PER REVOLUTION (PPR)	METER SETTING
Any	1	1000

DIESEL ENGINES

Modern diesel engines usually have camshaft sensors or electronic injector pumps. If there is one injector per cylinder, the signal from the pump drive will be 1/2 PPR. Similarly, if there is a camshaft sensor signal the signal will be 1/2 PPR. Set the calibration at a reading of 500.

If there is no electronic cam sensing or fuel injection in your diesel engine, the procedure is more complex. A signal can be obtained from the alternator by attaching a wire directly to the winding of the stator before it goes to one of the rectifier diodes. This signal will be proportional to engine speed, but the

Programming Instructions for : RPM Tachometer 2 1/16" Controller

proportionality must be learned. See the TACH CALIBRATION procedure for details, using meter setting 0 to force learning.

SPECIAL SCALING FUNCTIONS

Several Proparts meters require a setup procedure to define the kind of input they are looking at. These are:

Tachometer – the user needs to tell it the number of “pulses per revolution” (PPR) coming into its sense line. This number varies widely between makes and models of cars. The default value is an eight cylinder engine with 4 PPR. The program setting is 4000RPM.

Speedometer – the user needs to tell it the number of pulses that come in, per mile of travel.

O2 sensor – the user needs to tell it whether the sensor is narrowband (with a 0-1 volt output) or a wideband sensor with a 0...5 volt output. Once the meter is hooked up, the procedures are relatively painless.

TO SET UP SCALING

Turn the ignition off and on again to assure that the meter is in a reset state.

If it starts up with the face changing color and the pointer going up and down continuously, the meter is in demo mode. Press the center button before continuing.

TACH CALIBRATION

First read the section on TACHOMETER SENSE LINE ATTACHMENTS AND METER SCALING in order to find out how you need to set the meter. When you have figured out what PPR setting you are to use, press the Mode and Up buttons simultaneously for five (5) seconds. The dial will flash blue rapidly. This places the meter in the scale-setting mode. Use the Down and Up buttons to move the meter pointer to the appropriate RPM reading according to the table. If you have selected an “RPM” reading of 1000 or up, just press the center button to leave the scale setting mode and resume normal operation with the selected scaling.

If you were forced to use the alternator as a signal source, you selected an RPM of “0.” Now you must tell the motor when it is operating at 2000 RPM. Using a strobe light, slowly increase the engine speed till you hit 2000 RPM. The meter will read some nonzero value that increases and decreases with engine speed, but it will not be accurate. While the engine is running steadily at 2000 RPM, press the mode button. Your meter is calibrated. You can verify the setting by turning the ignition switch off and on again, starting the car, and checking whether the idle speed on your tachometer is the same as the speed you measure with a strobe light.

U.S. PATENT # 7,612,660

U.S. PATENT # 7,278,749

ADDITIONAL PATENTS PENDING

Flow Chart Programming Instructions for : RPM TACHOMETER 2 1/16" CONTROLLER



Patent Pending

All Rights Reserved

START HERE

PROGRAM MAIN MENU

(Press one button at a time)

MAIN MENU



TACHOMETER NORMAL MODE

Down Button
Mode Button
Up Button



NORMAL OPERATION:
Press the center button to save and advance to **PEAK PLAYBACK.**

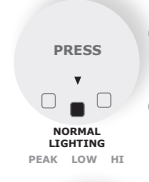

NORMAL OPERATION:
ON POWER UP THE GAUGE READS THE RPM.
Press the center button to save and advance to **PEAK PLAYBACK.**
OPTION: SELECT PULSES PER REVOLUTION (PPR)



PEAK PLAYBACK:
Pointer will now display peakplayback. Press the RIGHT or LEFT button to adjust dial brightness. Press the center button to advance to **HIGH "RACING" RED-LINE SETTING.**



PEAK PLAYBACK:
Press the center button to advance to **HIGH "RACING" RED-LINE SETTING.** OR
OPTION:RESTORE FACTORY DEFAULT



HIGH "RACING" RED-LINE SETTING:
Press the RIGHT or LEFT button to move dial pointer to the high setting. Press the center button to save and advance to **LOW RACING YELLOW-LINE SETTING.**



HIGH "RACING" RED-LINE SETTING:
Press the center button to advance to **LOW RACING YELLOW-LINE SETTING.**
OPTION:SET THRESHOLD ALERT SIGNAL



LOW RACING YELLOW-LINE SETTING:
Press the RIGHT or LEFT button to move pointer to low SETTING. Press the center button to save and advance to **COLOR SCHEME.**



LOW RACING YELLOW-LINE SETTING:
Press the center button to advance to **COLOR SCHEME.**

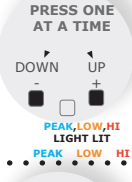

COLOR SCHEME:
Press down and up buttons to select a color scheme. (OFF-VIOLET-BLUE-GREEN-YELLOW-ORANGE-RED-WHITE). Press the center button to save and advance to **NORMAL OPERATION.**



COLOR SCHEME:
Press the center button to advance to **NORMAL OPERATION.** OR
OPTION A:DEMO MODE



Dial Brightness:
Press down and up buttons to adjust dial brightness. Press the center button to save and return to **NORMAL OPERATION**



Dial Brightness:
Press the center button to save and return to **NORMAL OPERATION.** OR
OPTION: POINTER BRIGHTNESS

Flow Chart Programming Instructions for : RPM TACHOMETER 2 1/16" CONTROLLER

SUBMENU

(ENTER FROM MAIN MENU)

(Press two(2) buttons simultaneously for 5 seconds)

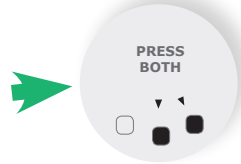

OPTION: SELECT PPR (Pulses Per Revolution)

The WHITE/DIMMER circuit must be installed and produce 12vdc before PPR can be programmed. While in **NORMAL OPERATION**, press and hold center and right buttons for 5 seconds. Dial will flash blue rapidly. Press down and up buttons to select PPR value by moving dial pointer to corresponding RPM. Press the center button to save and return to **NORMAL OPERATION**. (See PPR Chart Page 4-5)

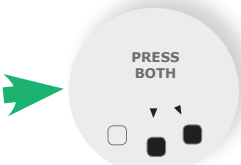

OPTION: RESTORE FACTORY DEFAULT:

While in **PEAK PLAYBACK**, press and hold the center and right buttons for five seconds. Dial pointer will step five times and return to zero. This will erase all user-programmed calibrations and settings, and return to **NORMAL OPERATION**.



U.S. Patent # 7,612,660 & 7,278,749

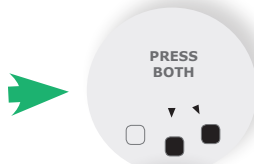

OPTION A: DEMO MODE:

WHILE IN **COLOR SCHEME**, press and hold the center and right buttons for five seconds. Dial will scroll through the seven color schemes. The **HI, LOW** and **PEAK** will light, and the dial pointer will move. Press the center button to return to **NORMAL OPERATION**.

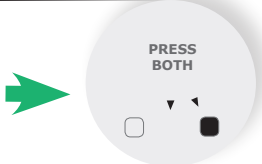

OPTION : POINTER BRIGHTNESS:

While in **DIAL BRIGHTNESS**, press and hold the center and left buttons for five seconds to enter pointer brightness mode. The dial pointer will start to flash and point to the upper right.



OPTION: POINTER BRIGHTNESS:

Press down and up buttons to adjust the pointer brightness. Press the center button to save and return to **NORMAL OPERATION**