

INSTALLATION INSTRUCTIONS MINI TACHOMETER

For use on 4, 6 or 8 cylinder engines with standard ignitions
This product not valid for race contingency money.



Engine Cylinder Adjustments

This tachometer has been factory calibrated for 8 cylinder operation. To adjust for 4 and 6 cylinder engines use a small screwdriver to turn the switch on the back of the tachometer until the arrow is pointing to the desired cylinder number.

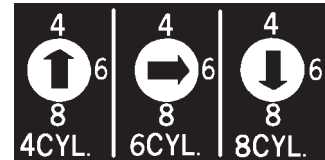
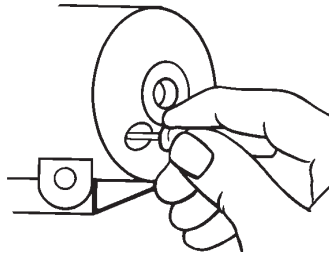

NOTE: If your tachometer does not function correctly when connecting the green wire to an aftermarket ignition box, such as MSD, etc., it may become necessary to use an aftermarket tachometer adapter such as MSD's 8910 or 8920. Contact MSD for further details on their adapters.

Mounting

The mounting base design offers a variety of mounting options for best visibility.

- The base can be mounted in forward or backward position as shown.
- The base can be attached in two different ways: use the screws provided or use the self-adhesive mounting pad. (For adhesive mounting, remove the protective paper and firmly press in desired location.)

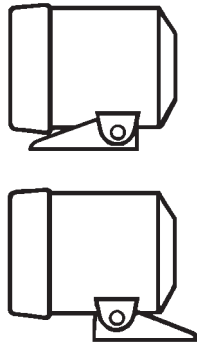

IMPORTANT

The pointer on your tachometer will not always rest at zero when the engine is off. This is normal. When the engine is started, the pointer will register the correct RPM.

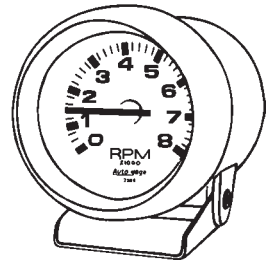

Wiring

Connect wires as shown. The wiring diagram shows installation on vehicles with original equipment ignitions. If your car is equipped with a specialty aftermarket ignition, please refer to the ignition manufacture for the proper hookup of your tachometer.

Troubleshooting

If your tachometer does not function properly after hookup, please check the following:

- If RPM reading seems incorrect, check cylinder selector switch for proper position.
- If there is no RPM reading, check RED wire (12V), GREEN wire (tach trigger), and BLACK wire (ground) for good connection.
- If tachometer reads erratically, check ignition points for point bounce or for problems with spark plug wires.
- If problem persists contact Auto Meter's service department for assistance.

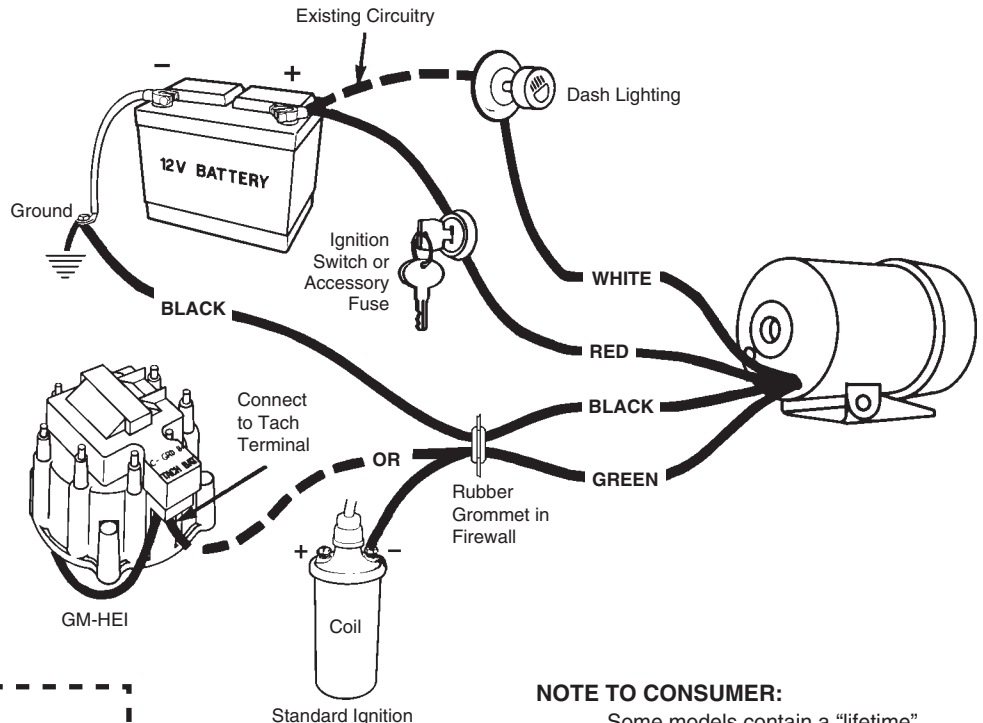

CAUTION!

As a safety precaution the Red wire of this product should be fused before connecting it to the positive (+) side of the 12V DC battery. We recommend using a 4 Amp, 3AG fast-acting type cartridge fuse (Littlefuse® # 312 004 or an equivalent) inline with the Red wire of our product.

NOTE TO CONSUMER:

Some models contain a "lifetime" sealed light. It is not consumer serviceable. In the unlikely event that the light should ever fail, the tach must be returned to Auto Meter Products for a no-charge light replacement.

All tachometer in the Auto gage 2300 series work on the following ignitions:

Chrysler Blue Box	Ford Standard Electronic
Chrysler Gold Box	MSD (with tach terminal)
Chrysler Silver Box	Most other OEM standard CD, and electronic ignitions.
GM HEI	

Accel laser I & II, and BEI ignitions are compatible with the Auto gage 2300 series tachometers when used with Auto Meter **Model 5215 BEI/Laser Adaptor**. **Laser II** with date code of **8100 or higher** do not require adaptor and use Figure B for hook-up.

Figure A is for **Chrysler Blue Box, Chrysler Gold Box, Chrysler Silver Box, Ford Standard Electronic** ignitions, and most other **OEM Standard, CD** and electronic ignitions.

Fig. A

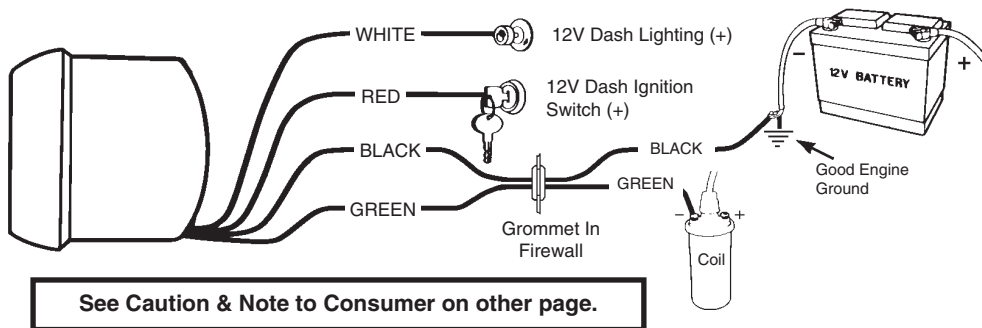

Figure B is for ignitions that provide a tach terminal, including **GM HEI**, and **MSD** (except **MSD-5**)

Fig. B

WARNING
Warranty will be void if connected to coil when using an aftermarket ignition box such as, but not limited to products from the following manufacturers: MSD, Crane, Jacobs, Mallory, Holley, Etc.. Prior to installation of your tachometer, check with the ignition box manufacturer for recommended tachometer signal location.

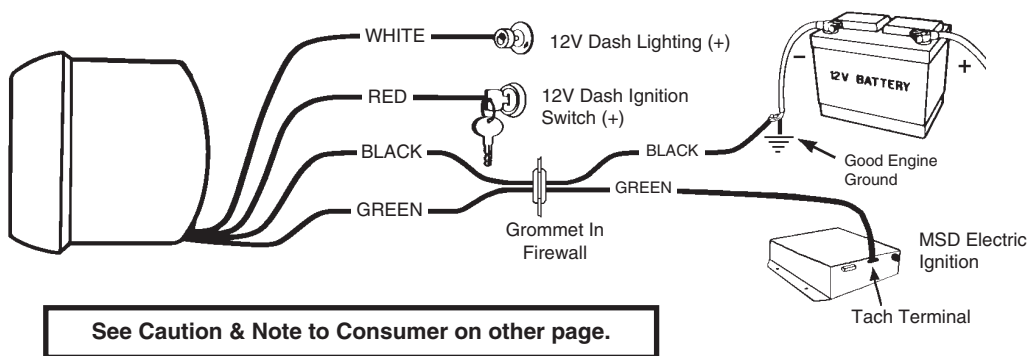
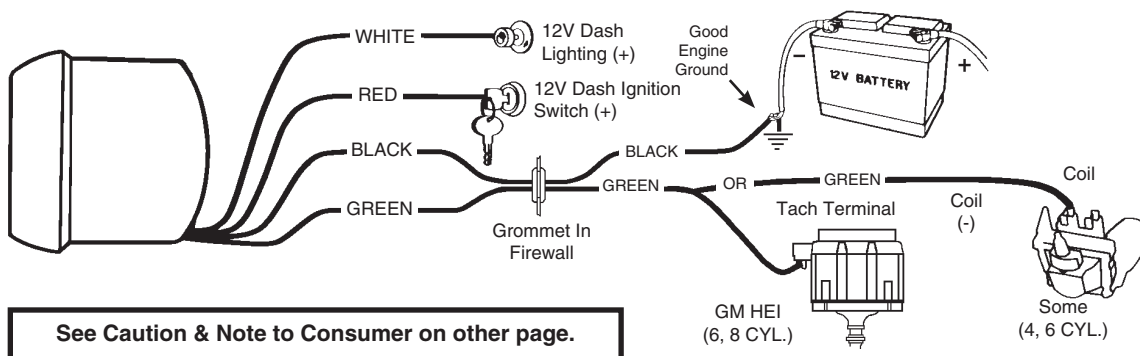

Figure C is for **GM HEI** ignitions.

Fig. C



AutoGage Service

For service send your gauge to Auto Meter in a well packed shipping carton. Please include a note explaining what the problem is, the year and model of your vehicle, engine size, etc., and your phone number. If you are sending a gauge back for Warranty adjustment, you must include a copy (or original) of your sales receipt from the place of purchase.