

INSTALLATION INSTRUCTIONS FUEL LEVEL SENDER

2650-1192-00 Rev. A



NOTE: This fuel tank sending unit is not intended to replace any existing fuel senders that have an existing fuel pick up tube. This sender is not intended to replace a sender that is mounted in the side or bottom of the tank. This sender will only replace an existing sending unit if the existing sender had the same 5-screw mounting flange, and no fuel pick up tube. This sending unit can replace some 6-screw mounting flange senders with the use of an Auto Meter (model #3263) adapter ring. There are no adapter rings available for sending units that used the spin-lock ring to secure the sender. If you have an existing sender that this sender is not intended to replace, you may install this sender into the top of the tank, on a flat surface, with a 1-1/2" hole. Leave your existing sender in place to plug the hole and/or to continue serving as your fuel pick up. Use extreme caution if you are making a new 1-1/2" hole in the top of any fuel tank that ever had fuel in it. Any fuel vapors can be extremely flammable!

Installation Procedure (Tank must be empty, clean and free of fuel.)

CAUTION:

If working on a tank that contains fuel or fuel vapors, use extreme caution. Carefully follow these steps to minimize danger from explosive fuel vapor.

1. Extinguish all cigarettes and remove open flames, hot material and anything else that might ignite fuel or fuel vapor from area. Be sure there is adequate ventilation in work area.
2. Remove ignition key and disconnect ground (-) cable from battery.
3. Drain fuel from tank and remove the drained fuel from area. Disconnect the fuel line from the fuel tank. Remove the mounting straps or bolts which fasten the fuel tank to the vehicle then remove tank.
4. If replacing an existing sender, remove the old sender and remove all remains of the gasket from the old sender from the fuel tank. A clean surface is required for proper sealing of the new fuel sender and neoprene/cork gasket. If excessive debris is found in the fuel tank, flush with water and thoroughly dry the tank with forced air. If you are not replacing an existing sender, and are creating a new hole in the top of the tank, and the tank is used, you must completely drain and clean the inside of the tank. Some installers will even fill the tank with water after thorough flushing, prior to drilling the 1-1/2" hole (using a 1-1/2" hole saw for metal). After drilling the hole, drain the water (if used), flush thoroughly, and let dry completely before installing the sender, or re-filling with fuel.
5. Measure tank depth where the new fuel sender will be installed. Refer then to ADJUSTMENT TABLE 1 for correct lengths of float arm (Length "A") and stem (Length "B"). Adjust the length of the stem by loosening the adjusting screws. Retighten the screws when the correct length is reached. Remove the float arm from the assembly and cut to Length "A". Reattach float arm to the float arm connector with set screw and locknut See FIGURE 2.
6. Slide the gasket over the float arm and sending unit to fit flat against the underside of the mounting plate. Place the fuel sender in the fuel tank and align the five holes in the sender flange with the holes in the fuel tank. The five mounting holes are not equally spaced and will only line up in one angular position. This allows repositioning of the float arm relative to the mounting holes every 90°. If necessary to rotate the sending unit for your installation, loosen the brass nut on the bottom of the mounting plate enough to allow the stem to rotate. Make sure to rotate the stem in 90° increments to insure clearance of the float arm with the tank wall.

FIGURE 1

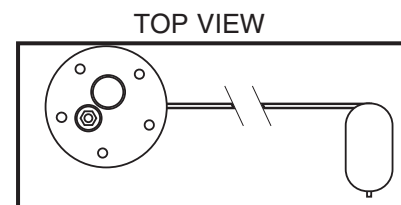

Adjustment Table 1

Adjustment Table, INCH			Adjustment Table, MILLIMETER		
TANK DEPTH	FLOAT ARM "A" Length	STEM "B" Length	TANK DEPTH	FLOAT ARM "A" Length	STEM "B" Length
5"	1 5/8"	2 9/16"	127 mm	41 mm	65 mm
5 1/2"	2"	2 13/16"	140	51	71
6"	2 5/16"	3 1/16"	152	59	78
6 1/2"	2 11/16"	3 5/16"	165	68	84
7"	3"	3 9/16"	178	76	90
7 1/2"	3 3/8"	3 13/16"	191	86	97
8"	3 3/4"	4 1/16"	203	95	103
8 1/2"	4 1/16"	4 5/16"	216	103	110
9"	4 3/8"	4 9/16"	229	113	116
9 1/2"	4 3/4"	4 13/16"	241	121	122
10"	5 1/8"	5 1/16"	254	130	129
10 1/2"	5 7/16"	5 5/16"	267	138	135
11"	5 13/16"	5 9/16"	279	148	141
11 1/2"	6 3/16"	5 13/16"	292	157	148
12"	6 1/2"	6 1/16"	305	165	154
12 1/2"	6 7/8"	6 5/16"	318	175	160
13"	7 3/16"	6 9/16"	330	183	167
13 1/2"	7 9/16"	6 13/16"	343	192	173
14"	7 7/8"	7 1/16"	356	200	179
14 1/2"	8 1/4"	7 5/16"	368	210	188
15"	8 9/16"	7 9/16"	381	217	192
15 1/2"	8 15/16"	7 13/16"	394	227	198
16"	9 5/16"	8 1/16"	406	237	205
16 1/2"	9 5/8"	8 5/16"	419	244	211
17"	10"	8 9/16"	432	254	217
17 1/2"	10 5/16"	8 13/16"	445	262	224
18"	10 11/16"	9 1/16"	457	271	230
18 1/2"	11"	9 5/16"	470	279	237
19"	11 3/8"	9 9/16"	483	289	243
19 1/2"	11 3/4"	9 13/16"	495	298	249
20"	12 1/16"	10 1/16"	508	306	256
20 1/2"	12 7/16"	10 5/16"	521	316	262
21"	12 3/8"	10 9/16"	533	324	268
21 1/2"	13 1/8"	10 13/16"	546	333	275
22"	13 1/16"	11 1/16"	559	341	281
22 1/2"	13 13/16"	11 5/16"	572	351	287
23"	14 1/8"	11 9/16"	584	359	294
23 1/2"	14 1/2"	11 13/16"	597	368	300
24"	14 7/8"	12 1/16"	610	378	307

7. Check for adequate clearance between float and fuel tank wall. (By holding fuel level sender up along side of the fuel tank, you can better check for clearance of vertical tank wall). If the tank wall interferes with the travel of the float arm, loosen the stem mounting nut and rotate the stem to a position where the float will clear the tank wall.
8. Place the fuel level sender back in the fuel tank and check for clearance between the float and the bottom of the tank. The float cannot touch the bottom of the tank. If the float does touch the bottom of the tank, double check the tank depth, float arm length and stem length. Make the appropriate adjustments to the sender and recheck it.
9. Tighten all of the fuel sender's adjustment fasteners including the stem mounting nut, stem adjustment screws, and the float arm set screw and locknut.
10. Install the fuel level sender and gasket in the tank using the five flange screws. Leak test this area to ensure a proper seal. If unsure how to perform any of the above or below procedures, or are unsure of electrical wiring connections, seek the services of a qualified individual.
11. Reconnect the wire from the fuel level gauge to the sender terminal stud with the nuts provided. If the fuel tank is not metal or if it is fastened to the vehicle with only straps, a separate wire from one of the five flange screws to a good chassis ground is necessary.
12. Connect grounded wire to one of the mounting flange screws. You may share this ground with the gauge ground if you wish.

13. Tighten all the sender's fasteners and reinstall the fuel tank in the vehicle. Reattach the fuel line to the tank and tighten the drain plug.

NOTE: BEFORE REMOUNTING TANK, MAKE SURE TO CHECK FOR LEAKS AND TEST OPERATION.

FIGURE 2

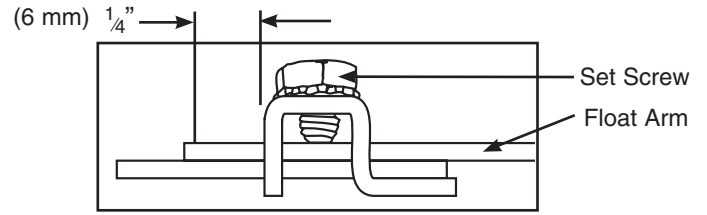

SIDE VIEW of Set Screw

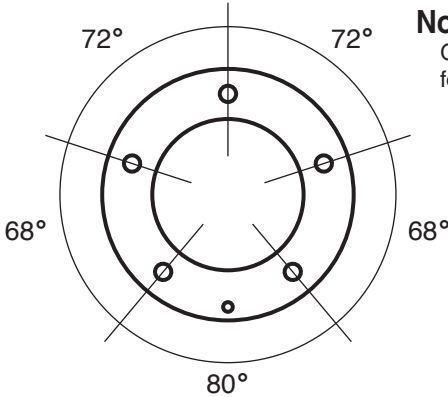

Note:

Gasket can also be used as a template for the mounting hole location.

IMPORTANT:

This fuel level sender is equipped with a five hole mounting flange. If your vehicle uses a six hole flange, an adapter plate will be required (Auto Meter model # 3263).

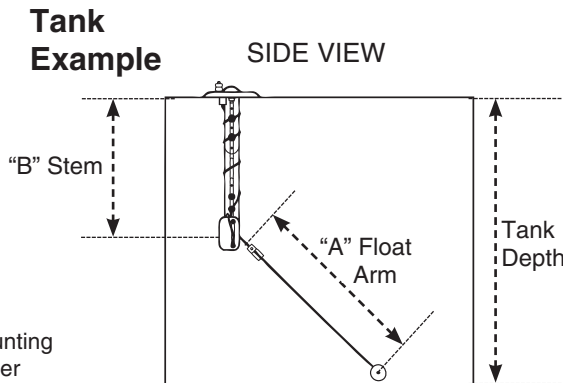

Place wire between case and bracket.

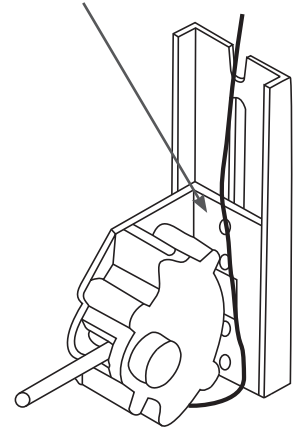

FIGURE 3