

Trademarks

Autel®, MaxiSys®, and MaxiDAS® are trademarks of Autel Intelligent Technology Corp., Ltd., registered in China, the United States and other countries. All other marks are trademarks or registered trademarks of their respective holders.

Safety Information

For your own safety and the safety of others, and to prevent damage to the equipment and vehicles upon which it is used, it is important that the safety instructions presented throughout this manual be read and understood by all persons operating or coming into contact with the equipment.



There are various procedures, techniques, tools, and parts for servicing vehicles, as well as in the skill of the individual doing the work. Because of the vast number of test applications and variations in the products that can be tested with this instrument, we cannot possibly anticipate or provide advice or safety messages to cover every situation.

It is the automotive technician's responsibility to be knowledgeable of the system being tested. It is essential to use proper service methods and test procedures. It is important to perform tests in an appropriate and acceptable manner that does not endanger your safety, the safety of others in the work area, the equipment being used, or the vehicle being tested.

Before using the equipment, always refer to and follow the safety messages and applicable test procedures provided by the manufacturer of the vehicle or equipment being tested. Use the equipment only as described in this manual. Read, understand, and follow all safety messages and instructions in this manual.



Safety Messages

Safety messages are provided to help prevent personal injury and equipment damage. All safety messages are introduced by a signal word indicating the hazard level.

-  **DANGER:** Indicates an imminently hazardous situation which, if not avoided, will result in death or serious injury to the operator or to bystanders.
-  **WARNING:** Indicates a potentially hazardous situation which, if not avoided, could result in death or serious injury to the operator or to bystanders.

Safety Instructions

The safety messages herein cover situations Autel is aware of. Autel cannot know, evaluate or advise you as to all of the possible hazards. You must be certain that any condition or service procedure encountered does not jeopardize your personal safety.

-  **DANGER:** When an engine is operating, keep the service area WELL VENTILATED or attach a building exhaust removal system to the engine exhaust system. Engines produce carbon monoxide, an odorless, poisonous gas that causes slower reaction time and can lead to serious personal injury or loss of life.
-  **WARNINGS:**
 - Always perform automotive testing in a safe environment.
 - Wear safety eye protection that meets ANSI standards.
 - Keep clothing, hair, hands, tools, test equipment, etc. away from all moving or hot engine parts.
 - Operate the vehicle in a well ventilated work area, for exhaust gases are poisonous.
 - Put the transmission in PARK (for automatic transmission) or NEUTRAL (for manual transmission) and make sure the parking brake is engaged.
 - Put blocks in front of the drive wheels and never leave the vehicle unattended while testing.
 - Be extra cautious when working around the ignition coil, distributor cap, ignition wires and spark plugs. These components create hazardous voltages when the engine is running.
 - Keep a fire extinguisher suitable for gasoline, chemical, and electrical fires nearby.
 - Do not connect or disconnect any test equipment while the ignition is on or the engine is running.
 - Keep the test equipment dry, clean, free from oil, water or grease. Use a mild detergent in a clean cloth to clean the outside of the equipment as necessary.
 - Do not drive the vehicle and operate the test equipment at the same time. Any distraction may cause an accident.
 - Refer to the service manual for the vehicle being serviced and adhere to all diagnostic procedures and precautions. Failure to do so may result in personal injury or damage to the test equipment.
 - To avoid damaging the test equipment or generating false data, make sure the vehicle battery is fully charged and the connection to the vehicle DLC is clean and secure.
 - Do not place the test equipment on the distributor of the vehicle. Strong electro-magnetic interference can damage the equipment.

PRODUCT DESCRIPTIONS

The MaxiSys MS919 provides full functions and online repair information needed when diagnosing vehicles, identifying faults and researching repairs. It features a powerful octa-core processor and 9.7-inch TFT-LCD capacitive touch screen for swift diagnosis and optimum viewing. As an intelligent diagnostic and information system, the MaxiSys MS919 not only displays relevant repairs gathered from experienced industry experts, but provides step-by-step guidance to ensure the repair is done correctly and efficiently.

The MaxiSys MS919 has two main components:

- MaxiSys Display Tablet – the central processor and monitor for the system
- VCMI – the vehicle communication and measurement interface

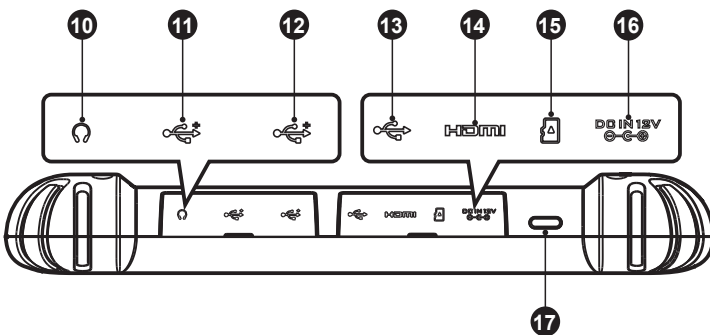
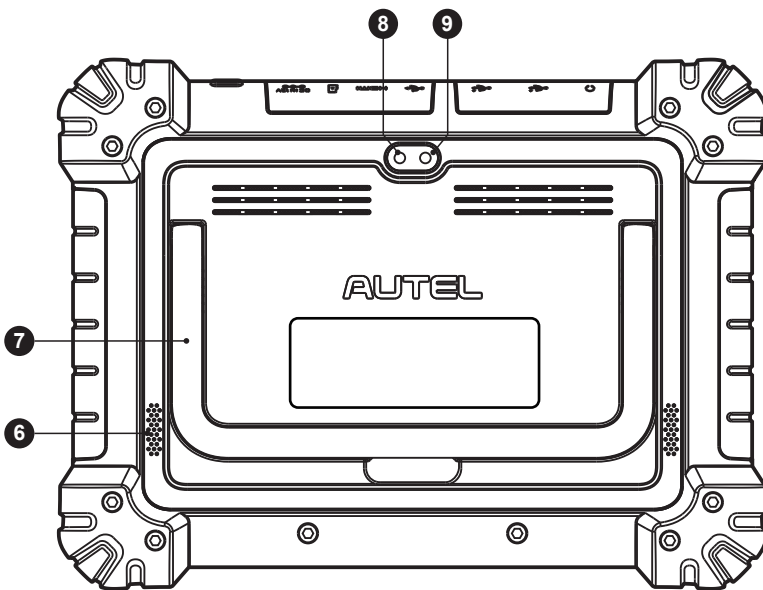
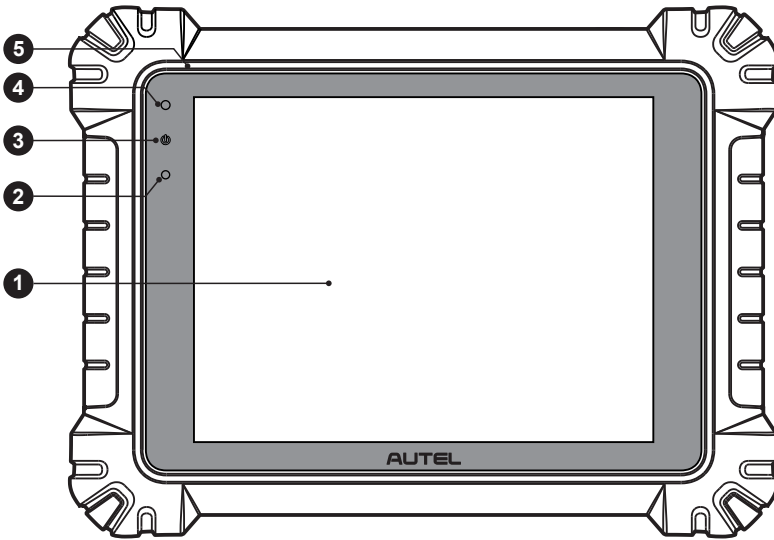

1. 9.7" TFT-LCD Capacitive Touch Screen
2. Ambient Light Sensor – detects ambient brightness
3. Power LED
4. Front Camera
5. Microphone
6. Speaker
7. Collapsible Stand – extends from the back to allow hands-free viewing of the tablet
8. Rear Camera
9. Camera Flash
10. Headphone Jack
11. USB Port
12. USB Port
13. Mini USB Port
14. HDMI (High-Definition Multimedia Interface) Port
15. Mini SD Card Slot
16. DC Power Supply Input Port
17. Lock/Power Button – long press to turn on and off the Display Tablet, or tap the power button to lock the screen

MAXISYS MS919

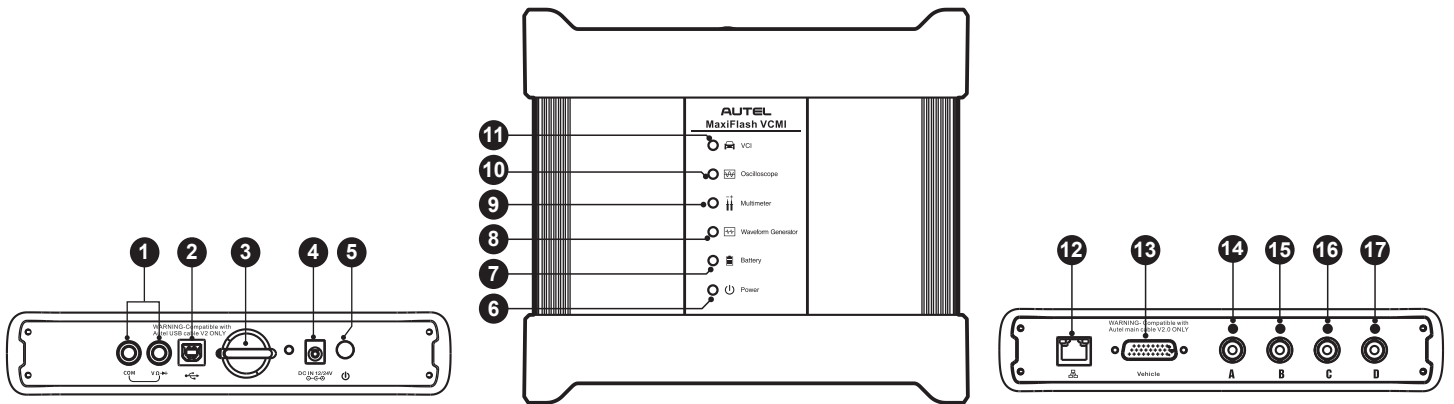

MaxiFlash VCM1

- | | |
|---|--|
| <ol style="list-style-type: none"> 1. Multimeter Jacks 2. USB Port 3. Hook 4. DC Power Supply Input Port 5. Power Button 6. Power LED – refer to Table 1-1 Power LED Description for details 7. Battery LED - refer to Table 1-2 Battery LED Description for details 8. Waveform Generator LED - lights green when operating in the waveform generator mode 9. Multimeter LED - lights green when operating in the multimeter mode | <ol style="list-style-type: none"> 10. Oscilloscope LED - flashes green when operating in the oscilloscope mode 11. Vehicle LED - refer to Table 1-3 Vehicle LED Description for details 12. Ethernet Port 13. Vehicle Data Connector (DB26-Pin) 14. Input Channel A 15. Input Channel B 16. Input Channel C 17. Input Channel D |
|---|--|



IMPORTANT: Do not disconnect this programming device while the vehicle LED is on! If programming is interrupted while the vehicle's ECU is blank or only partially programmed, the module may be unrecoverable.

Table 1-1 Power LED Description

LED	Color	Description
Power	Yellow	Lights yellow automatically at power up when VCM1 is self-testing.
	Green	Lights solid green when powered on.
	Red	<ul style="list-style-type: none"> • Lights solid red when system failure occurs. • Flashes red when VCM1 is upgrading.

Table 1-2 Battery LED Description

LED	Color	Description
Battery	Green	<ul style="list-style-type: none"> • Flashes green when VCM1 is charging. • Lights solid green when fully charged or the battery level is above 50%.
	Yellow	Lights yellow when the battery level is above 25% but below 50%.
	Red	<ul style="list-style-type: none"> • Lights red when the battery level is above 10% but below 25%. • Flashes red when the battery level is below 10%.

Table 1-3 Vehicle LED Description

LED	Color	Description
Vehicle	Green	Lights solid green when connected via USB cable. Flashes green when communicating.
	Blue	Lights solid blue when connected via BT. Flashes blue when communicating.
	Cyan (Blue/Green)	Lights solid cyan when connected via Wi-Fi. Flashes cyan (blue/green) when communicating.
	Magenta (Blue/Red)	Lights solid magenta when connected via Internet cable. Flashes magenta (blue/red) when communicating.

GETTING STARTED



IMPORTANT: Before operating or maintaining this unit, please read these instructions carefully, paying extra attention to the safety warnings and precautions. Use this unit correctly and with care. Failure to do so may cause damage and/or personal injury and will void the limited product warranty.



WARNING: The MaxiFlash VCMI is compatible with Autel main cable V2.0 and USB cable V2 only.

1

Connect the main cable V2.0 to the Vehicle Data Connector on the VCMI unit, and tighten the thumb screws.

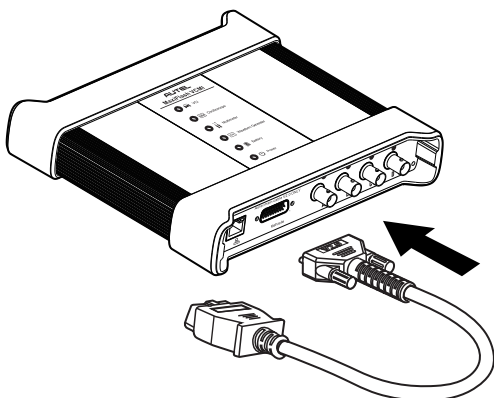

2

Connect the cable's 16-pin adapter to the vehicle's DLC, which is generally located under the vehicle dash.

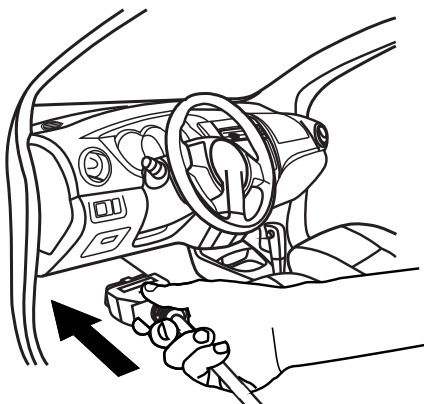

3

Power up the Display Tablet. Ensure the tablet has a charged battery or is connected to the DC power supply.

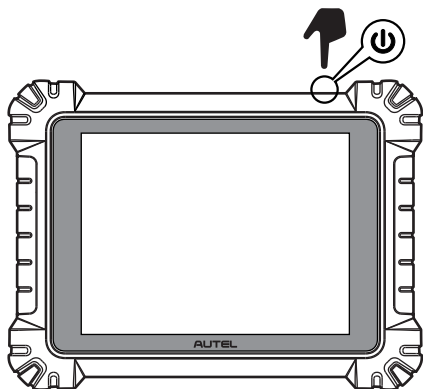

4

Select one of the three methods shown below, Bluetooth, Wi-Fi or USB cable V2, to connect the Display Tablet with the VCMI device and establish a communication link. Use only the USB cable connection when programming.

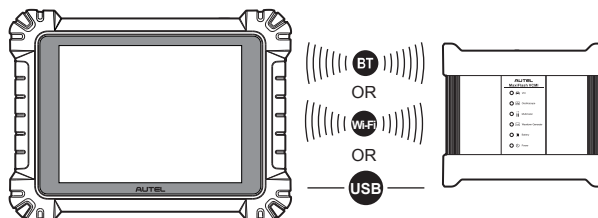

5

When the VCMI device is properly connected to the vehicle and the Display Tablet, the VCMI status button on the bottom bar on the screen shows a green mark, indicating the system is ready to start vehicle diagnosis.

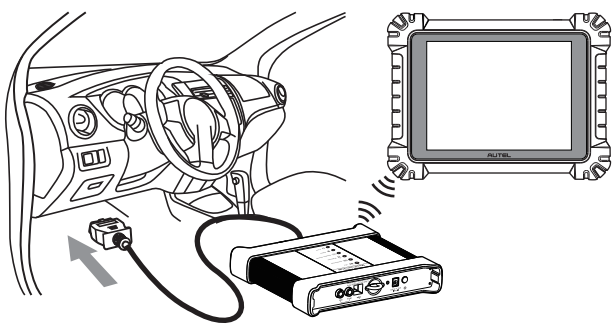

6

The Measurement application enables testing of electrical wiring, circuits, and systems.



Thank you for purchasing AUTEL MaxiSys MS919. Autel manufactures its tools to the highest standards. If properly maintained and used according to instructions, the MS919 will provide years of trouble-free use.

Learn more about diagnostic and testing tools we have.