



AUROLA BEARING COMPANY

Aircraft Bearings Guidebook



The *Motion - Transfer* Specialists



ASM-T & ASB-T MALE ROD ENDS

Aerospace Series AS81935/1 (Right Hand) & AS81935/1 (Left Hand)

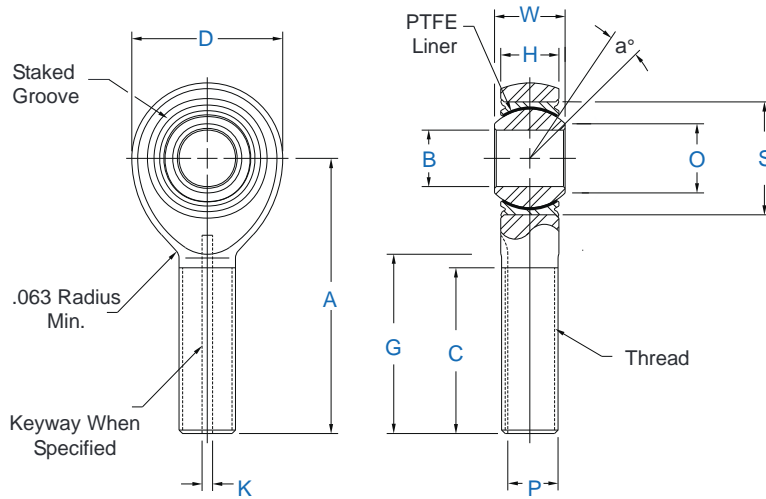

MILITARY NO.		AURORA NO.		DIMENSIONS IN INCHES										
Right Hand	Left Hand	Right Hand	Left Hand	B +.0000 -.0005	W +.000 -.002	H ± .005	A ± .010	D ± .010	O Min.	S Max. Housing I.D.	Ball Dia. Ref.	G +.000 -.020	K +.005 -.000	P +.000 -.005
M81935/1-03	M81935/1-03L	ASM-3T	ASB-3T	.1900	.437	.337	1.562	.806	.300	.6250	.531	.980	.062	.268
M81935/1-04	M81935/1-04L	ASM-4T	ASB-4T	.2500	.437	.337	1.562	.806	.300	.6250	.531	.980	.062	.268
M81935/1-05	M81935/1-05L	ASM-5T	ASB-5T	.3125	.437	.327	1.875	.900	.360	.6875	.593	1.270	.062	.268
M81935/1-06	M81935/1-06L	ASM-6T	ASB-6T	.3750	.500	.416	1.938	1.025	.470	.8125	.687	1.235	.093	.319
M81935/1-07	M81935/1-07L	ASM-7T	ASB-7T	.4375	.562	.452	2.125	1.150	.540	.9062	.781	1.402	.093	.383
M81935/1-08	M81935/1-08L	ASM-8T	ASB-8T	.5000	.625	.515	2.438	1.337	.610	1.0000	.875	1.589	.093	.445
M81935/1-10	M81935/1-10L	ASM-10T	ASB-10T	.6250	.750	.577	2.625	1.525	.750	1.1875	1.062	1.683	.125	.541
M81935/1-12	M81935/1-12L	ASM-12T	ASB-12T	.7500	.875	.640	2.875	1.775	.850	1.3750	1.250	1.808	.125	.663
M81935/1-14	M81935/1-14L	ASM-14T	ASB-14T	.8750	.875	.765	3.375	2.025	1.000	1.6250	1.375	2.121	.156	.777
M81935/1-16	M81935/1-16L	ASM-16T	ASB-16T	1.0000	1.375	1.015	4.125	2.775	1.270	2.1250	1.875	2.464	.187	1.136

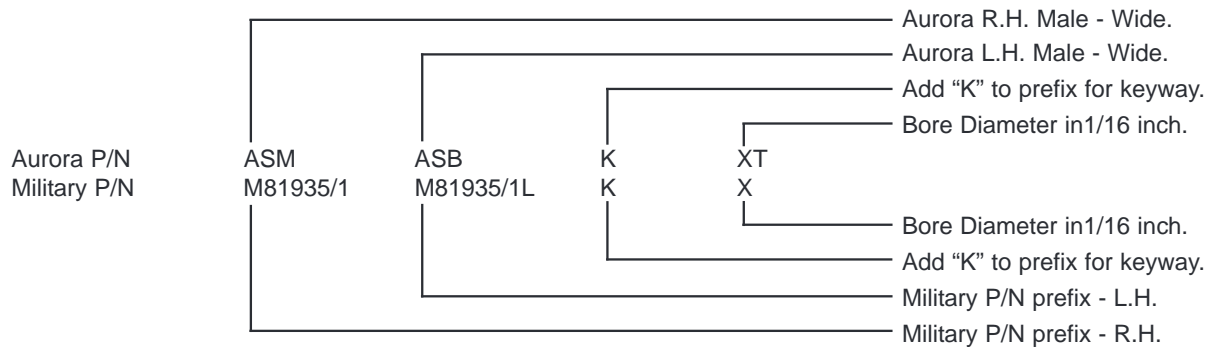



ASM-T & ASB-T MALE ROD ENDS

Aerospace Series AS81935/1 (Right Hand) & AS81935/1 (Left Hand)

Specifications	
BODY	4340 Alloy Steel (AMS S 5000) Heat Treated Cadmium Plated
BALL	440C Stainless Steel (AMS 5630) Heat Treated
RACE	17 4 PH Stainless Steel (AMS 5643) Heat Treated
LINER	AT 3200 Bearing Liner, Permanently Bonded to Race I.D. Qualified to SAE AS81820

C ± .031	Thread UNJF-3A	a° Misalign. Angle Min.	Approx. Brg. Wt. Lbs.	Ult. Static Radial Load Lbs.	Fatigue Load Lbs.	Axial Proof Load Lbs.	No Load Rotational Breakaway Torque* In-Lbs.		AURORA NO.		MILITARY NO.	
							Min.	Max.	Right Hand	Left Hand	Right Hand	Left Hand
.968	5/16-24	15	.072	2,360	1,470	1,000	.5	6	ASM-3T	ASB-3T	M81935/1-03	M81935/1-03L
.968	5/16-24	15	.072	4,860	2,380	1,000	.5	6	ASM-4T	ASB-4T	M81935/1-04	M81935/1-04L
1.187	5/16-24	14	.087	7,180	2,770	1,100	1	15	ASM-5T	ASB-5T	M81935/1-05	M81935/1-05L
1.187	3/8-24	8	.136	8,550	3,570	1,660	1	15	ASM-6T	ASB-6T	M81935/1-06	M81935/1-06L
1.281	7/16-20	10	.183	12,000	4,800	1,850	1	15	ASM-7T	ASB-7T	M81935/1-07	M81935/1-07L
1.468	1/2-20	9	.278	19,500	7,680	2,040	1	15	ASM-8T	ASB-8T	M81935/1-08	M81935/1-08L
1.562	5/8-18	12	.424	21,900	9,180	2,430	1	15	ASM-10T	ASB-10T	M81935/1-10	M81935/1-10L
1.687	3/4-16	13	.639	29,300	11,600	2,810	1	15	ASM-12T	ASB-12T	M81935/1-12	M81935/1-12L
2.000	7/8-14	6	.963	34,500	13,100	3,320	1	24	ASM-14T	ASB-14T	M81935/1-14	M81935/1-14L
2.343	1 1/4-12	12	2.546	80,300	30,400	4,340	1	24	ASM-16T	ASB-16T	M81935/1-16	M81935/1-16L

Temperature Range: -65°F - +325°F (-54°C - +163°C)

*No load rotational breakaway torque can be varied to meet specific application requirements.

Add letter "K" to prefix to designate keyway, Ex.: ASMK-6T

As applicable, keyway will conform to SAE-AS81935/1 or NAS 559.

All threads are rolled after heat treatment, and conform to UNJF-3A per AS 8879.

AT 3200 Bearing Liner System is qualified for procurement under SAE-AS81820.

Rod End Bearings listed are manufactured to conform to the dimensions, materials, and configurations of SAE-AS81935/1, and are approved for procurement under this specification.

Stainless Steel bodies (not approved to military specs) as well as other non-standard material, dimensional or configuration specifications can be provided.

The Rod End Bearings listed are available (not approved to military specs) in non PTFE lined, metal on metal configuration, as well as with alternate Aurora Bearing PTFE liner systems.



ASW-T & ASG-T FEMALE ROD ENDS

Aerospace Series AS81935/2 (Right Hand) & AS81935/2 (Left Hand)

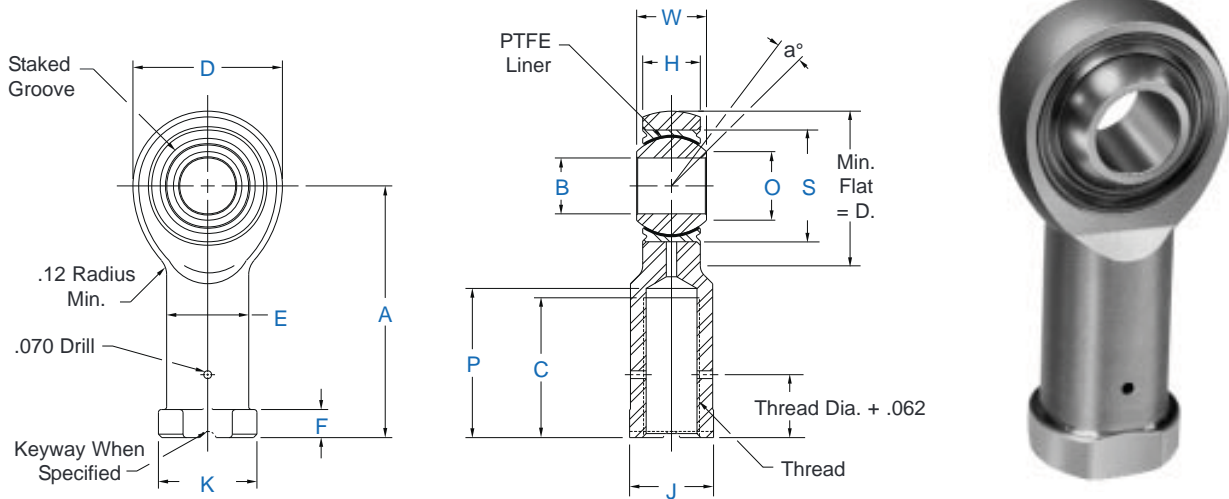

MILITARY NO.		AURORA NO.		DIMENSIONS IN INCHES											
Right Hand	Left Hand	Right Hand	Left Hand	B +.0000 -.0005	W + .000 -.002	H ± .005	A ± .010	D ± .010	O Min.	S Max. Housing I.D.	E ± .010	K Ref. Dia.	J +.002 -.010	F +.010 -.062	Ball Dia. Ref.
M81935/2-03	M81935/2-03L	ASW-3T	ASG-3T	.1900	.437	.337	1.375	.806	.300	.6250	.422	.500	.437	.188	.531
M81935/2-04	M81935/2-04L	ASW-4T	ASG-4T	.2500	.437	.337	1.469	.806	.300	.6250	.422	.500	.437	.188	.531
M81935/2-05	M81935/2-05L	ASW-5T	ASG-5T	.3125	.437	.327	1.625	.900	.360	.6875	.485	.580	.500	.250	.593
M81935/2-06	M81935/2-06L	ASW-6T	ASG-6T	.3750	.500	.416	1.812	1.025	.470	.8125	.547	.660	.562	.250	.687
M81935/2-07	M81935/2-07L	ASW-7T	ASG-7T	.4375	.562	.452	2.000	1.150	.540	.9062	.610	.720	.625	.250	.781
M81935/2-08	M81935/2-08L	ASW-8T	ASG-8T	.5000	.625	.515	2.250	1.337	.610	1.0000	.735	.880	.750	.250	.875
M81935/2-10	M81935/2-10L	ASW-10T	ASG-10T	.6250	.750	.577	2.500	1.525	.750	1.1875	.860	1.020	.875	.375	1.062
M81935/2-12	M81935/2-12L	ASW-12T	ASG-12T	.7500	.875	.640	2.875	1.775	.850	1.3750	.985	1.160	1.000	.375	1.250
M81935/2-14	M81935/2-14L	ASW-14T	ASG-14T	.8750	.875	.765	3.375	2.025	1.000	1.6250	1.110	1.300	1.125	.500	1.375
M81935/2-16	M81935/2-16L	ASW-16T	ASG-16T	1.0000	1.375	1.015	4.125	2.775	1.270	2.1250	1.688	2.020	1.750	.563	1.875

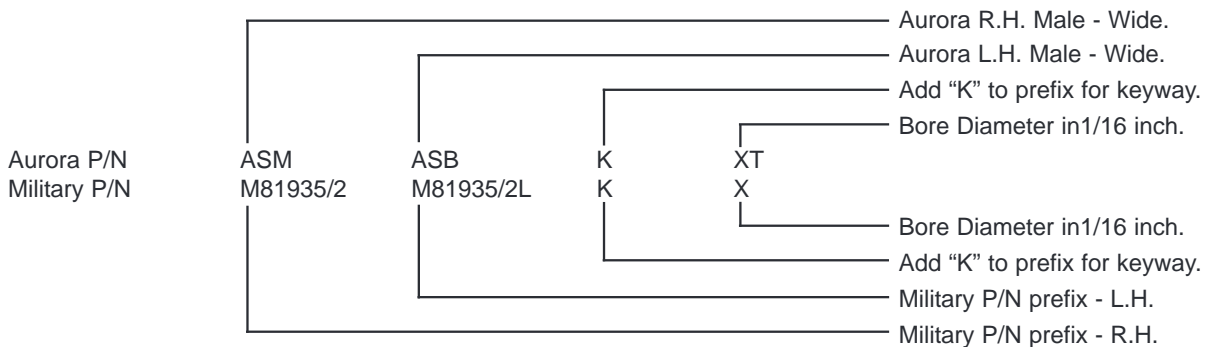



ASW-T & ASG-T FEMALE ROD ENDS

Aerospace Series AS81935/2 (Right Hand) & AS81935/2 (Left Hand)

Specifications	
BODY	4340 Alloy Steel (AMS S 5000) Heat Treated Cadmium Plated
BALL	440C Stainless Steel (AMS 5630) Heat Treated
RACE	17 4 PH Stainless Steel (AMS 5643) Heat Treated
LINER	AT 3200 Bearing Liner, Permanently Bonded to Race I.D. Qualified to SAE AS81820

P Max.	C Min.	Thread UNJF-3B	a° Misalign. Angle Min.	Approx. Brg. Wt. Lbs.	Ult. Static Radial Load Lbs.	Fatigue Load Lbs.	Axial Proof Load Lbs.	No Load Rotational Breakaway Torque* In-Lbs.		AURORA NO.		MILITARY NO.	
								Min.	Max.	Right Hand	Left Hand	Right Hand	Left Hand
.875	.750	5/16 24	15	.080	2,360	1,470	1,000	.5	6	ASW-3T	ASG-3T	M81935/2-03	M81935/2-03L
.875	.750	5/16 24	15	.084	4,860	2,380	1,000	.5	6	ASW-4T	ASG-4T	M81935/2-04	M81935/2-04L
1.000	.875	3/8 24	14	.102	7,180	3,020	1,100	1	15	ASW-5T	ASG-5T	M81935/2-05	M81935/2-05L
1.125	1.000	3/8 24	8	.161	8,550	3,570	1,660	1	15	ASW-6T	ASG-6T	M81935/2-06	M81935/2-06L
1.250	1.125	7/16 20	10	.212	12,000	4,800	1,850	1	15	ASW-7T	ASG-7T	M81935/2-07	M81935/2-07L
1.375	1.250	1/2 20	9	.325	19,500	8,260	2,040	1	15	ASW-8T	ASG-8T	M81935/2-08	M81935/2-08L
1.500	1.375	5/8 18	12	.481	21,900	9,180	2,430	1	15	ASW-10T	ASG-10T	M81935/2-10	M81935/2-10L
1.750	1.625	3/4 16	13	.673	29,300	11,600	2,810	1	15	ASW-12T	ASG-12T	M81935/2-12	M81935/2-12L
2.062	1.875	7/8 14	6	.959	34,500	13,100	3,320	1	24	ASW-14T	ASG-14T	M81935/2-14	M81935/2-14L
2.312	2.125	1 1/4 12	12	2.717	80,300	30,400	4,340	1	24	ASW-16T	ASG-16T	M81935/2-16	M81935/2-16L

Temperature Range: -65°F - +325°F (-54°C - +163°C)

*No load rotational breakaway torque can be varied to meet specific application requirements.

Add letter "K" to prefix to designate keyway, Ex.: ASWK-6T

As applicable, keyway will conform to SAE-AS81935/3 or NAS 559.

All threads are rolled after heat treatment, and conform to UNJF-3A per AS 8879.

AT 3200 Bearing Liner System is qualified for procurement under SAE-AS81820.

Rod End Bearings listed are manufactured to conform to the dimensions, materials, and configurations of SAE-AS81935/2, and are approved for procurement under this specification.

Stainless Steel bodies (not approved to military specs) as well as other non-standard material, dimensional or configuration specifications can be provided.

The Rod End Bearings listed are available (not approved to military specs) in non PTFE lined, metal on metal configuration, as well as with alternate Aurora Bearing PTFE liner systems.



ANC-TG & ANC-T SPHERICAL BEARINGS

Narrow - Aerospace Series AS14101 (Grooved) & AS14104 (Plain)

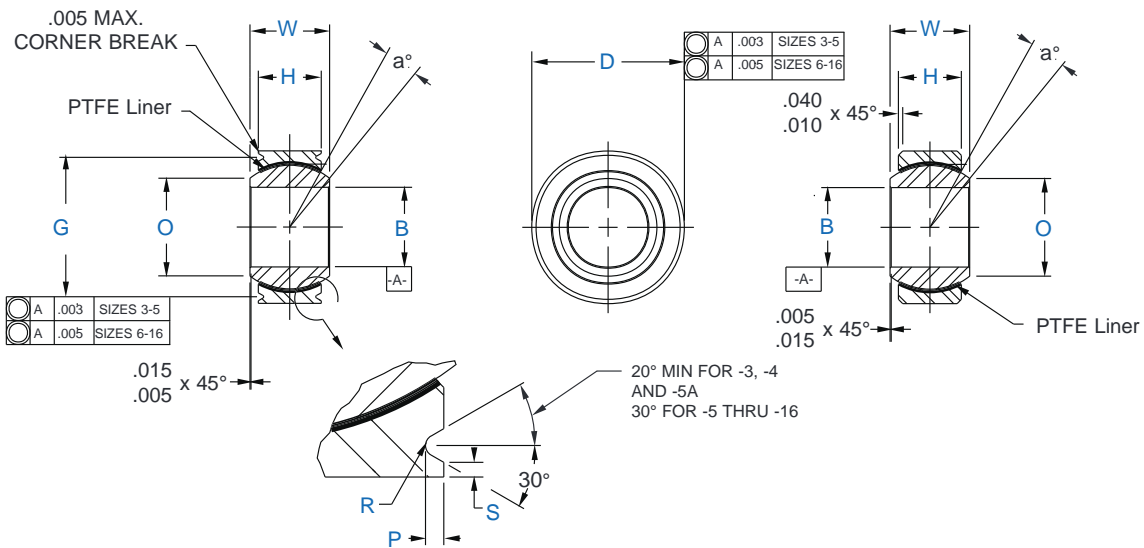

MILITARY NO.		AURORA NO.		DIMENSIONS IN INCHES										
GROOVED	PLAIN	GROOVED	PLAIN	B + .0000 - .0005	D + .0000 - .0005	W + .000 - .002	H ±.005	O Min.	P + .000 - .010	S Min.	G + .000 - .008	R \pm + .002 - .005	Ball Dia. Ref.	a°
MS14101-3	MS14104-3	ANC-3TG	ANC-3T	.1900	.5625	.281	.218	.293	.025	.010	.500	.010	.406	10
MS14101-4	MS14104-4	ANC-4TG	ANC-4T	.2500	.6562	.343	.250	.364	.025	.010	.594	.010	.500	10
MS14101-5†	MS14104-5	ANC-5TG†	ANC-5T	.3125	.7500	.375	.281	.419	.035	.020	.650	.010	.562	10
MS14101-6	MS14104-6	ANC-6TG	ANC-6T	.3750	.8125	.406	.312	.475	.035	.020	.712	.015	.625	9
MS14101-7	MS14104-7	ANC-7TG	ANC-7T	.4375	.9062	.437	.343	.530	.035	.020	.806	.015	.687	8
MS14101-8	MS14104-8	ANC-8TG	ANC-8T	.5000	1.0000	.500	.390	.600	.055	.020	.876	.015	.781	8
MS14101-9	MS14104-9	ANC-9TG	ANC-9T	.5625	1.0937	.562	.437	.670	.055	.020	.970	.015	.875	8
MS14101-10	MS14104-10	ANC-10TG	ANC-10T	.6250	1.1875	.625	.500	.739	.055	.020	1.063	.015	.968	8
MS14101-12	MS14104-12	ANC-12TG	ANC-12T	.7500	1.4375	.750	.593	.920	.055	.020	1.313	.015	1.187	8
MS14101-14	MS14104-14	ANC-14TG	ANC-14T	.8750	1.5625	.875	.703	.980	.055	.020	1.438	.015	1.312	8
MS14101-16	MS14104-16	ANC-16TG	ANC-16T	1.0000	1.7500	1.000	.797	1.118	.055	.020	1.626	.015	1.500	9

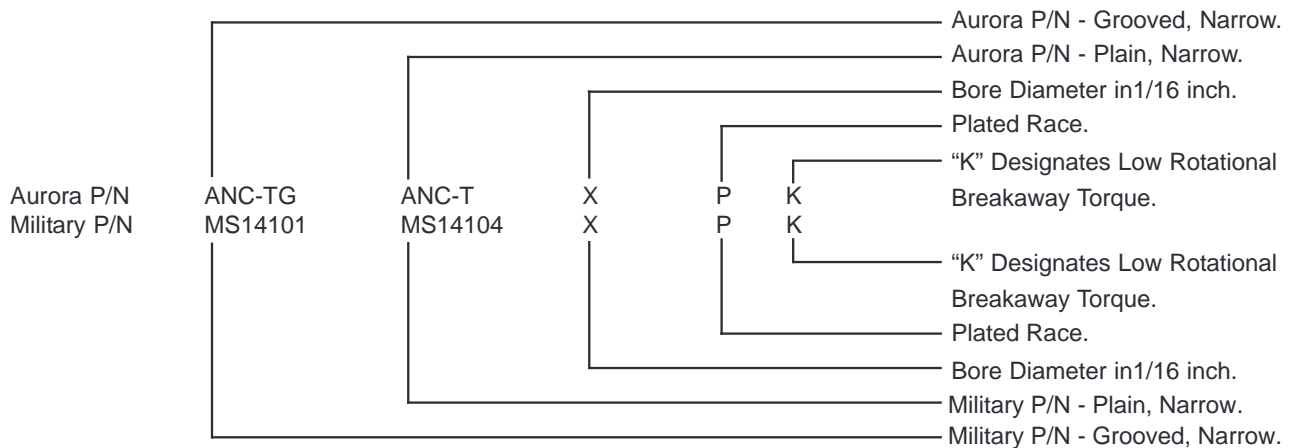

Aurora P/N - Grooved, Narrow.
 Aurora P/N - Plain, Narrow.
 Bore Diameter in/16 inch.
 Plated Race.
 "K" Designates Low Rotational Breakaway Torque.
 "K" Designates Low Rotational Breakaway Torque.
 Plated Race.
 Bore Diameter in/16 inch.
 Military P/N - Plain, Narrow.
 Military P/N - Grooved, Narrow.



ANC-TG & ANC-T SPHERICAL BEARINGS

Narrow - Aerospace Series AS14101 (Grooved) & AS14104 (Plain)

Specifications	
BALL	440C Stainless Steel (AMS 5630) Heat Treated
RACE	17-4 PH Stainless Steel (AMS 5643) Heat Treated
LINER	AT 3200 Bearing Liner, Permanently Bonded to Race I.D. Qualified to SAE-AS81820



**GROOVED
SERIES**



**PLAIN
SERIES**

Bearing Fits												
Radial Lbs.	Axial Lbs.	Oscil- lating Load Lbs.	Standard Fit		"K" Fit		Approx. Brg. Wt. Lbs.	AURORA NO.		MILITARY NO.		
			No Load Rotational Breakaway Torque Max. In-Lbs.	No Load Rotational Breakaway Torque Max. In-Lbs.	Radial Clearance Max.	Axial Clearance Max.		GROOVED	PLAIN	GROOVED	PLAIN	
3,975	150	1,500	0.25 - 5.0	0.5	.0007	.0028	.020	ANC-3TG	ANC-3T	MS14101-3	MS14104-3	
6,040	430	3,320	0.25 - 5.0	0.5	.0007	.0028	.020	ANC-4TG	ANC-4T	MS14101-4	MS14104-4	
8,750	700	5,460	0.25 - 8.0	1.0	.0007	.0028	.030	ANC-5TG†	ANC-5T	MS14101-5‡	MS14104-5	
10,540	1,100	6,600	0.25 - 8.0	1.0	.0007	.0028	.040	ANC-6TG	ANC-6T	MS14101-6	MS14104-6	
13,200	1,400	8,050	0.25 - 8.0	1.0	.0007	.0028	.050	ANC-7TG	ANC-7T	MS14101-7	MS14104-7	
17,900	2,100	10,400	0.25 - 8.0	1.0	.0007	.0028	.070	ANC-8TG	ANC-8T	MS14101-8	MS14104-8	
23,200	3,680	13,000	0.25 - 8.0	1.0	.0007	.0028	.090	ANC-9TG	ANC-9T	MS14101-9	MS14104-9	
30,500	4,720	16,450	0.25 - 8.0	1.0	.0007	.0028	.120	ANC-10TG	ANC-10T	MS14101-10	MS14104-10	
46,400	6,750	23,600	0.25 - 8.0	1.0	.0007	.0028	.210	ANC-12TG	ANC-12T	MS14101-12	MS14104-12	
62,200	9,350	30,250	0.25 - 12.0	2.0	.0010	.0040	.270	ANC-14TG	ANC-14T	MS14101-14	MS14104-14	
82,200	12,160	38,000	0.25 - 12.0	2.0	.0010	.0040	.390	ANC-16TG	ANC-16T	MS14101-16	MS14104-16	

Temperature Range: -65°F - +325°F (-54°C - +163°C)

No load rotational breakaway torque can be varied to meet specific application requirements.

Standard fit bearings are void of any "radial" or "axial" clearance

AT 3200 Bearing Liner System is qualified for procurement under SAE-AS81820.

Spherical Bearings listed are manufactured to conform to the dimensions, materials, and configurations of SAE-AS14101 (Grooved) and SAE-AS14104 (Plain), and are approved for procurement under this specification.

Parts (not approved to military specs) in non-standard material, dimensional or configuration specifications can be provided.

The Spherical Bearings listed are available (not approved to military specs) in non PTFE lined, metal on metal configuration, as well as with alternate Aurora Bearing PTFE liner systems.

† 5TGA is available, identical to -5TG, with "G" = .660

‡ Sizes -3, -4, -5, -5A, "R" +005, -.010

Oversize Outside Diameter (dimension "D") parts per Military spec. suffix "T" (+.010") and suffix "U" (+.020") are available. Add suffix "D1" to specify .010" oversize, "D2" to specify .020" oversize. Ex.: ANC-6TGD1 (AS14101-6T) or ANC-9TD2 (AS14104-9U).



AWC-T & AWC-TG SPHERICAL BEARINGS

Wide - Aerospace Series AS14102 (Plain) & AS14103 (Grooved)

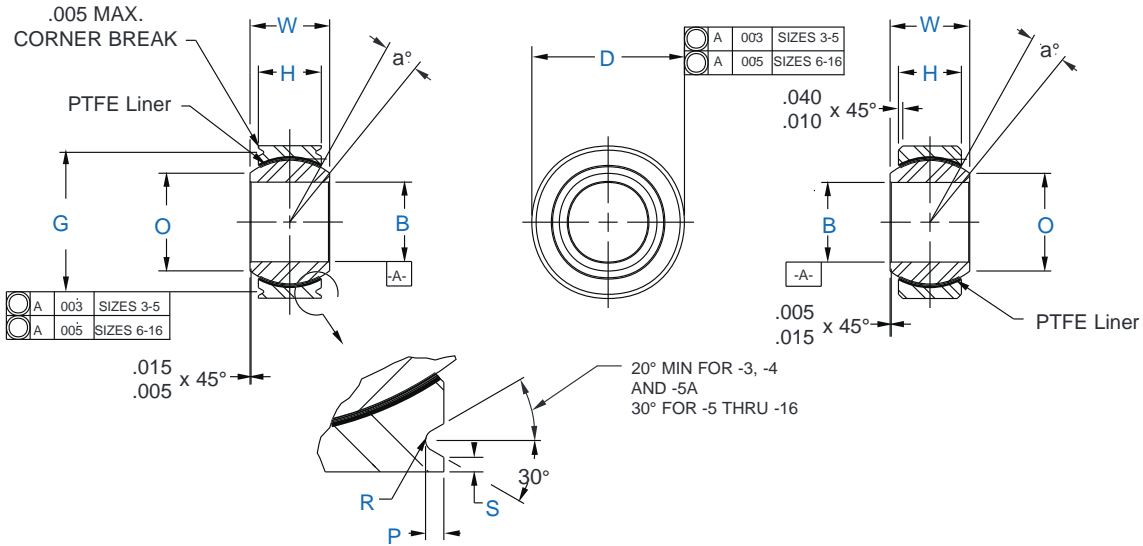

MILITARY NO.		AURORA NO.		DIMENSIONS IN INCHES										
GROOVED	PLAIN	GROOVED	PLAIN	B +.0000 -.0005	D +.0000 -.0005	W +.000 -.002	H ±.005	O Min.	P +.000 -.010	S Min.	G +.000 -.008	R ± +.002 -.005	Ball Dia. Ref.	a°
MS14103-3	MS14102-3	AWC-3TG	AWC-3T	.1900	.6250	.437	.327	.300	.025	.010	.563	.010	.531	15
MS14103-4	MS14102-4	AWC-4TG	AWC-4T	.2500	.6250	.437	.327	.300	.025	.010	.563	.010	.531	15
MS14103-5	MS14102-5	AWC-5TG	AWC-5T	.3125	.6875	.437	.317	.360	.025	.010	.625	.010	.593	14
MS14103-6	MS14102-6	AWC-6TG	AWC-6T	.3750	.8125	.500	.406	.466	.035	.020	.712	.015	.687	8
MS14103-7†	MS14102-7	AWC-7TG†	AWC-7T	.4375	.9375	.562	.442	.537	.035	.020	.837	.015	.781	10
MS14103-8	MS14102-8	AWC-8TG	AWC-8T	.5000	1.0000	.625	.505	.607	.035	.020	.900	.015	.875	9
MS14103-9	MS14102-9	AWC-9TG	AWC-9T	.5625	1.1250	.687	.536	.721	.035	.020	1.025	.015	1.000	10
MS14103-10	MS14102-10	AWC-10TG	AWC-10T	.6250	1.1875	.750	.567	.747	.035	.020	1.087	.015	1.062	12
MS14103-12	MS14102-12	AWC-12TG	AWC-12T	.7500	1.3750	.875	.630	.845	.055	.020	1.251	.015	1.250	13
MS14103-14	MS14102-14	AWC-14TG	AWC-14T	.8750	1.6250	.875	.755	.995	.055	.020	1.501	.015	1.375	6
MS14103-16	MS14102-16	AWC-16TG	AWC-16T	1.0000	2.1250	1.375	1.005	1.269	.055	.020	2.001	.015	1.875	12

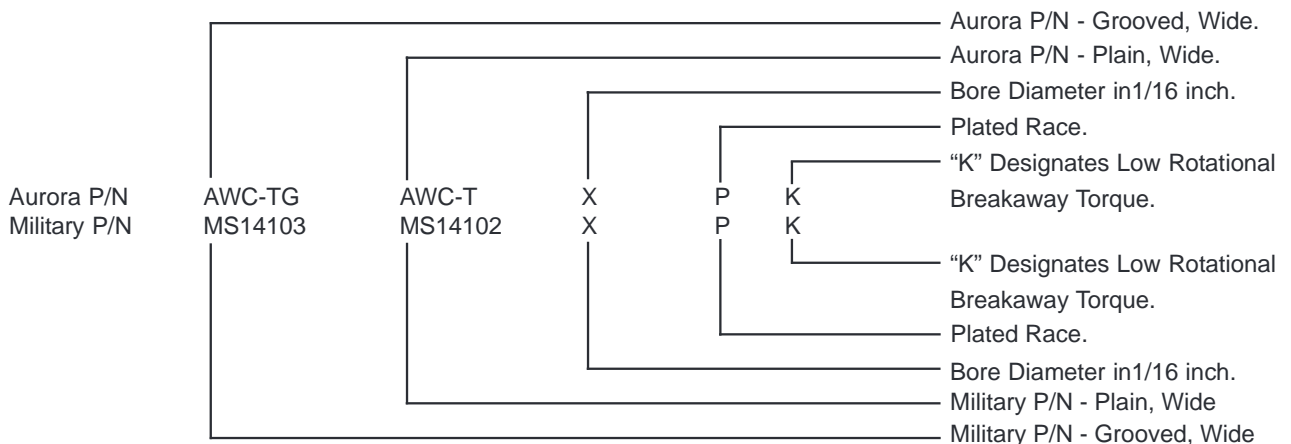

Absence of letter "P" indicates no plating on race. "E" designates Zinc-Nickel, "P" designates Zinc-Nickel or Cadmium.



AWC-T & AWC-TG SPHERICAL BEARINGS

Wide - Aerospace Series AS14102 (Plain) & AS14103 (Grooved)

Specifications	
BALL	440C Stainless Steel (AMS 5630) Heat Treated
RACE	17 4 PH Stainless Steel (AMS 5643) Heat Treated
LINER	AT 3200 Bearing Liner, Permanently Bonded to Race I.D. Qualified to SAE AS81820



**GROOVED
SERIES**



**PLAIN
SERIES**

Bearing Fits													
Radial Lbs.	Axial Lbs.	Oscil- lating Load Lbs.	Standard Fit		"K" Fit				Approx. Brg. Wt. Lbs.	AURORA NO.		MILITARY NO.	
			No Load Rotational Breakaway Torque Max. In-Lbs.		No Load Rotational Breakaway Torque Max. In-Lbs.		Radial Clearance Max.	Axial Clearance Max.		GROOVED	PLAIN	GROOVED	PLAIN
			0.25	5.0	0.5								
2,500	1,770	4,900	0.25	5.0	0.5		.0007	.0021	.031	AWC-3TG	AWC-3T	MS14103-3	MS14102-3
5,500	1,770	4,900	0.25	5.0	0.5		.0007	.0021	.031	AWC-4TG	AWC-4T	MS14103-4	MS14102-4
9,400	1,640	6,050	0.25	8.0	1.0		.0007	.0021	.035	AWC-5TG	AWC-5T	MS14103-5	MS14102-5
13,700	2,630	8,310	0.25	8.0	1.0		.0007	.0021	.060	AWC-6TG	AWC-6T	MS14103-6	MS14102-6
20,700	3,650	11,750	0.25	8.0	1.0		.0007	.0021	.080	AWC-7TG†	AWC-7T	MS14103-7†	MS14102-7
21,400	4,970	14,950	0.25	8.0	1.0		.0007	.0021	.100	AWC-8TG	AWC-8T	MS14103-8	MS14102-8
26,600	5,370	18,100	0.25	8.0	1.0		.0007	.0021	.135	AWC-9TG	AWC-9T	MS14103-9	MS14102-9
29,000	6,130	20,250	0.25	8.0	1.0		.0007	.0021	.160	AWC-10TG	AWC-10T	MS14103-10	MS14102-10
37,000	7,730	26,200	0.25	8.0	1.0		.0007	.0021	.240	AWC-12TG	AWC-12T	MS14103-12	MS14102-12
65,200	10,800	33,600	0.25	12.0	2.0		.0010	.0030	.350	AWC-14TG	AWC-14T	MS14103-14	MS14102-14
104,000	19,300	56,250	0.25	12.0	2.0		.0010	.0030	.970	AWC-16TG	AWC-16T	MS14103-16	MS14102-16

Temperature Range: -65°F - +325°F (-54°C - +163°C)

No load rotational breakaway torque can be varied to meet specific application requirements.

Standard fit bearings are void of any "radial" or "axial" clearance

AT 3200 Bearing Liner System is qualified for procurement under SAE-AS81820.

Spherical Bearings listed are manufactured to conform to the dimensions, materials, and configurations of SAE-AS14102 (Plain) and SAE-AS14103 (Grooved), and are approved for procurement under this specification.

Parts (not approved to military specs) in non-standard material, dimensional or configuration specifications can be provided.

The Spherical Bearings listed are available (not approved to military specs) in non PTFE lined, metal on metal configuration, as well as with alternate Aurora Bearing PTFE liner systems.

† 7TGA is available, identical to -7TG, with "D" = .9062" "G" = .808"

‡ Sizes -3, -4, -5, "R" +.005, -.010

Oversize Outside Diameter (dimension "D") parts per Military spec. suffix "T" (+.010") and suffix "U" (+.020") are available. Add suffix "D1" to specify .010" oversize, "D2" to specify .020" oversize. Ex.: AWC-6TD1 (AS14102-6T) or AWC-9TGD2 (AS14103-9U).



AJB-TA / -TC Straight Journal Bushings

SAE-AS81934/1

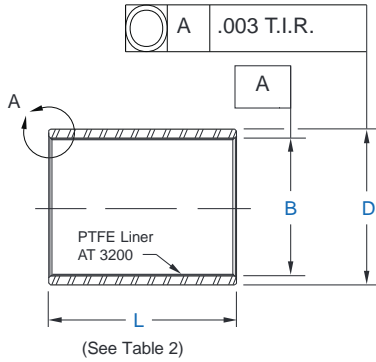

Specifications	
"A"	Aluminum Alloy QQ A 200/3 or QQ A 225/6 (2024T851 or 2024T8511), Chemical Film Treatment per MIL C 5541
"C"	Corrosion Resistant Steel, AMS 5643 (17 4 PH) Condition H 1150 per MIL H 6875, Passivated per QQ P 35 (Cad, or Zinc Nickel plate optional).
"T"	AT 3200 Bearing Liner System, Permanently Bonded to Bushing I.D. Qualified to SAE AS81820

BUSHING NO.		DIMENSIONS IN INCHES			Weight* Lbs./Inch (Ref) L-1.00	
Aluminum	Stainless Steel	B +.0000 -.0010	D ± .0005		Alum.	CRES
			Alum.	CRES		
AJB-4TA	AJB-4TC	.2515	.3760	.006	.016	
AJB-5TA	AJB-5TC	.3140	.4386	.007	.019	
AJB-6TA	AJB-6TC	.3765	.5012	.008	.022	
AJB-7TA	AJB-7TC	.4390	.5638	.009	.025	
AJB-8TA	AJB-8TC	.5015	.6265	.011	.028	
AJB-9TA	AJB-9TC	.5640	.6892	.012	.031	
AJB-10TA	AJB-10TC	.6265	.8142	.021	.056	
AJB-11TA	AJB-11TC	.6890	.8767	.022	.060	
AJB-12TA	AJB-12TC	.7515	.9393	.024	.065	
AJB-14TA	AJB-14TC	.8765	1.0645	.028	.075	
AJB-16TA	AJB-16TC	1.0015	1.1898	.031	.084	
AJB-18TA	AJB-18TC	1.1265	1.3148	.035	.094	
AJB-20TA	AJB-20TC	1.2515	1.4398	.038	.103	
AJB-22TA	AJB-22TC	1.3765	1.5648	.041	.113	
AJB-24TA	AJB-24TC	1.5015	1.7523	.062	.171	
AJB-26TA	AJB-26TC	1.6265	1.8773	.067	.183	
AJB-28TA	AJB-28TC	1.7515	2.0023	.071	.193	
AJB-32TA	AJB-32TC	2.0015	2.2523	.081	.222	

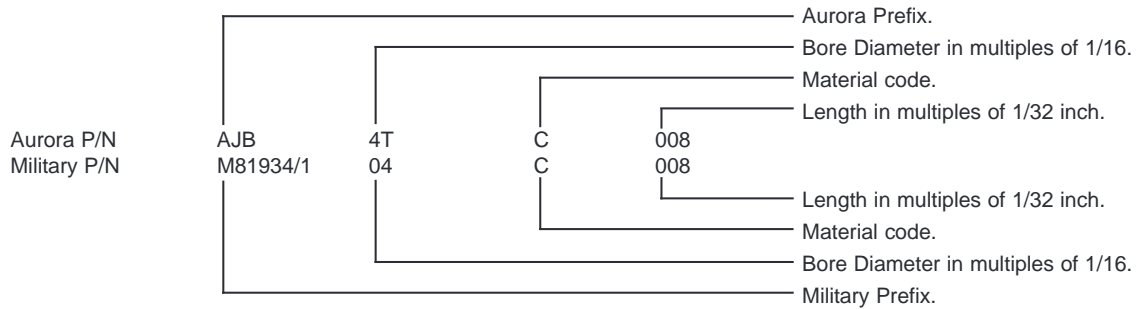

Example of weight calculation: AJB-16TA-008: (0.31 lb/in) x .250 = .078 lbs.



AJB-TA / -TC Straight Journal Bushings

SAE-AS81934/1

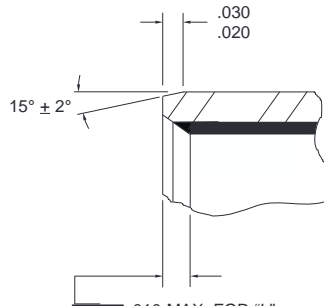

DETAIL A

.010 MAX. FOR "L"
.375 OR LESS
.025 MAX FOR ALL
OTHER LENGTHS.

TABLE 2A

DASH NO.	NOMINAL SIZE	Length L ^{+0.00} / _{-.010}															
		.156	.187	.218	.250	.281	.312	.343	.375	.437	.500	.562	.625	.687	.750	.875	
-04	1/4	005	006	007	008	009	010	011	012	014							
-05	5/16	005	006	007	008	009	010	011	012	014	016	018					
-06	3/8	005	006	007	008	009	010	011	012	014	016	018	020	022			
-07	7/16	005	006	007	008	009	010	011	012	014	016	018	020	022	024	028	
-08	1/2	005	006	007	008	009	010	011	012	014	016	018	020	022	024	028	
-09	9/16	005	006	007	008	009	010	011	012	014	016	018	020	022	024	028	
-10	5/8	005	006	007	008	009	010	011	012	014	016	018	020	022	024	028	
-11	11/16				008	009	010	011	012	014	016	018	020	022	024	028	
-12	3/4				008	009	010	011	012	014	016	018	020	022	024	028	
-14	7/8				008	009	010	011	012	014	016	018	020	022	024	028	
-16	1				008	009	010	011	012	014	016	018	020	022	024	028	
-18	1 1/8						010	011	012	014	016	018	020	022	024	028	
-20	1 1/4								012	014	016	018	020	022	024	028	
-22	1 3/8								012	014	016	018	020	022	024	028	
-24	1 1/2								012	014	016	018	020	022	024	028	
-26	1 5/8										016	018	020	022	024	028	
-28	1 3/4										016	018	020	022	024	028	
-32	2										016	018	020	022	024	028	

TABLE 2B

DASH NO.	NOMINAL SIZE	Length L ^{+0.00} / _{-.010}															
		1.000	1.125	1.250	1.375	1.500	1.625	1.750	1.875	2.000	2.125	2.250	2.375	2.500	2.750	3.000	
-04	1/4																
-05	5/16																
-06	3/8																
-07	7/16																
-08	1/2																
-09	9/16	032	036														
-10	5/8	032	036	040	044												
-11	11/16	032	036	040	044	048	052										
-12	3/4	032	036	040	044	048	052										
-14	7/8	032	036	040	044	048	052										
-16	1	032	036	040	044	048	052	056	060								
-18	1 1/8	032	036	040	044	048	052	056	060								
-20	1 1/4	032	036	040	044	048	052	056	060	064	068						
-22	1 3/8	032	036	040	044	048	052	056	060	064	068						
-24	1 1/2	032	036	040	044	048	052	056	060	064	068	072	076	080	088		
-26	1 5/8	032	036	040	044	048	052	056	060	064	068	072	076	080	088	096	
-28	1 3/4	032	036	040	044	048	052	056	060	064	068	072	076	080	088	096	
-32	2	032	036	040	044	048	052	056	060	064	068	072	076	080	088	096	

Stainless Steel parts (suffix "C") are available Cadmium plated (Suffix "P") or Zinc – Nickel plated (Suffix "E").
Ex.: AJB-4TC-008P or AJB-4TC-008E.

Oversize Outside Diameter (dimension "D") parts per Military spec. suffix "T" (+.010") and suffix "U" (+.020") are available.
Add suffix "D1" to specify .010" oversize, "D2" to specify .020" oversize. Ex.: AJB-4TC-008D1 or AJB-4TC-008D2.



AJB-TFA / -TFC Flanged Journal Bushings

SAE-AS81934/2

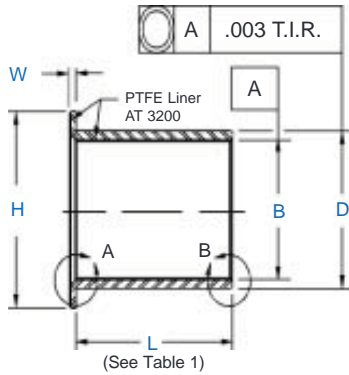

Specifications	
"A"	Aluminum Alloy QQ A 200/3 or QQ A 225/6 (2024T851 or 2024T8511), Chemical Film Treatment per MIL C 5541
"C"	Corrosion Resistant Steel, AMS 5643 (17 4 PH) Condition H 1150 per MIL H 6875, Passivated per QQ P 35 (Cad, or Zinc Nickel plate optional).
"T"	AT 3200 Bearing Liner System, Permanently Bonded to Bushing I.D. Qualified to SAE AS81820

BUSHING NO.		DIMENSIONS IN INCHES					Weight*		Flange Weight Lbs. (Ref)	
Aluminum	Stainless Steel	B +.0000 -.0010	D ± .0005	D +.0000 -.0005	H + .000 - .020	W + .000 - .005	Lbs./Inch (Ref)		L-1.00	
							Alum.	CRES	Alum.	CRES
AJB-4TFA	AJB-4TFC	.2515	.3760	.750	.0625	.006	.016	.002	.006	
AJB-5TFA	AJB-5TFC	.3140	.4386	.812	.0625	.007	.019	.003	.007	
AJB-6TFA	AJB-6TFC	.3765	.5012	.875	.0625	.008	.022	.003	.007	
AJB-7TFA	AJB-7TFC	.4390	.5638	.937	.0625	.009	.025	.003	.008	
AJB-7TFA-1	AJB-7TFC-1	.4390	.5638	.745	.0625	.009	.025	.003	.008	
AJB-8TFA	AJB-8TFC	.5015	.6265	1.000	.0625	.011	.028	.003	.009	
AJB-9TFA	AJB-9TFC	.5640	.6892	1.125	.0625	.012	.031	.004	.011	
AJB-10TFA	AJB-10TFC	.6265	.8142	1.250	.0625	.021	.056	.005	.014	
AJB-11TFA	AJB-11TFC	.6890	.8767	1.375	.0625	.022	.060	.006	.016	
AJB-12TFA	AJB-12TFC	.7515	.9393	1.500	.0625	.024	.065	.007	.020	
AJB-14TFA	AJB-14TFC	.8765	1.0645	1.625	.0625	.028	.075	.008	.022	
AJB-16TFA	AJB-16TFC	1.0015	1.1898	1.750	.0625	.031	.084	.009	.024	
AJB-18TFA	AJB-18TFC	1.1265	1.3148	1.875	.0937	.035	.094	.015	.041	
AJB-20TFA	AJB-20TFC	1.2515	1.4398	2.000	.0937	.038	.103	.016	.045	
AJB-22TFA	AJB-22TFC	1.3765	1.5648	2.125	.0937	.041	.113	.017	.048	
AJB-24TFA	AJB-24TFC	1.5015	1.7523	2.250	.0937	.062	.171	.018	.051	
AJB-26TFA	AJB-26TFC	1.6265	1.8773	2.375	.0937	.067	.183	.020	.055	
AJB-28TFA	AJB-28TFC	1.7515	2.0023	2.500	.0937	.071	.193	.021	.058	
AJB-32TFA	AJB-32TFC	2.0015	2.2523	2.750	.0937	.081	.222	.023	.065	

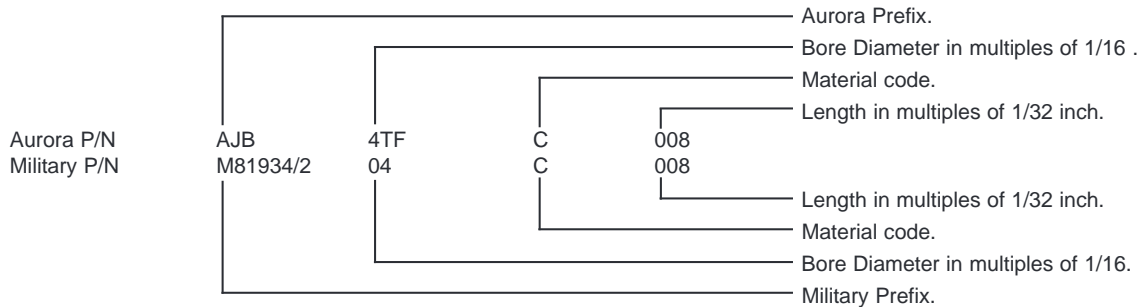

Example of weight calculation: AJB-16TFA-016:
 Sleeve Weight: (0.31 lb/in) x .500 = .0155 lbs
 Flange weight = .009 lbs
 Total weight = .0245 lbs



AJB-TFA / -TFC Flanged Journal Bushings

SAE-AS81934/2

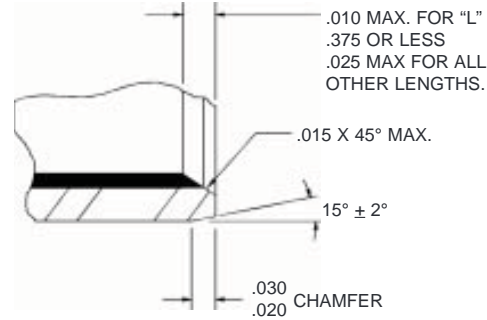
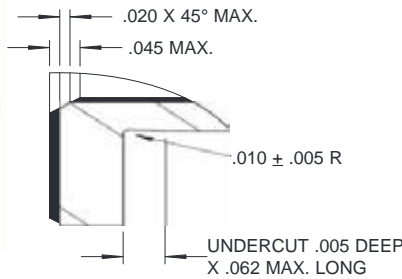

TABLE 1A

DETAIL A

DETAIL B

DASH NO.	NOMINAL SIZE	Length L $\begin{matrix} +.000 \\ -.010 \end{matrix}$															
		.156	.187	.218	.250	.281	.312	.343	.375	.437	.500	.562	.625	.687	.750	.875	
-04	1/4	005	006	007	008	009	010	011	012	014							
-05	5/16	005	006	007	008	009	010	011	012	014	016	018					
-06	3/8	005	006	007	008	009	010	011	012	014	016	018	020	022			
-07	7/16	005	006	007	008	009	010	011	012	014	016	018	020	022	024	028	
-08	1/2	005	006	007	008	009	010	011	012	014	016	018	020	022	024	028	
-09	9/16	005	006	007	008	009	010	011	012	014	016	018	020	022	024	028	
-10	5/8	005	006	007	008	009	010	011	012	014	016	018	020	022	024	028	
-11	11/16				008	009	010	011	012	014	016	018	020	022	024	028	
-12	3/4				008	009	010	011	012	014	016	018	020	022	024	028	
-14	7/8				008	009	010	011	012	014	016	018	020	022	024	028	
-16	1				008	009	010	011	012	014	016	018	020	022	024	028	
-18	1 1/8						010	011	012	014	016	018	020	022	024	028	
-20	1 1/4								012	014	016	018	020	022	024	028	
-22	1 3/8								012	014	016	018	020	022	024	028	
-24	1 1/2								012	014	016	018	020	022	024	028	
-26	1 5/8										016	018	020	022	024	028	
-28	1 3/4										016	018	020	022	024	028	
-32	2										016	018	020	022	024	028	

TABLE 1B

DASH NO.	NOMINAL SIZE	Length L $\begin{matrix} +.000 \\ -.010 \end{matrix}$															
		1.000	1.125	1.250	1.375	1.500	1.625	1.750	1.875	2.000	2.125	2.250	2.375	2.500	2.750	3.000	
-04	1/4																
-05	5/16																
-06	3/8																
-07	7/16																
-08	1/2																
-09	9/16	032	036														
-10	5/8	032	036	040	044												
-11	11/16	032	036	040	044	048	052										
-12	3/4	032	036	040	044	048	052										
-14	7/8	032	036	040	044	048	052										
-16	1	032	036	040	044	048	052	056	060								
-18	1 1/8	032	036	040	044	048	052	056	060								
-20	1 1/4	032	036	040	044	048	052	056	060	064	068						
-22	1 3/8	032	036	040	044	048	052	056	060	064	068						
-24	1 1/2	032	036	040	044	048	052	056	060	064	068	072	076	080	088		
-26	1 5/8	032	036	040	044	048	052	056	060	064	068	072	076	080	088	096	
-28	1 3/4	032	036	040	044	048	052	056	060	064	068	072	076	080	088	096	
-32	2	032	036	040	044	048	052	056	060	064	068	072	076	080	088	096	

Stainless Steel parts (suffix "C") are available Cadmium plated (Suffix "P") or Zinc – Nickel plated (Suffix "E").
Ex.: AJB-4TFC-008P or AJB-4TFC-008E.

Oversize Outside Diameter (dimension "D") parts per Military spec. suffix "T" (+.010") and suffix "U" (+.020") are available.
Add suffix "D1" to specify .010" oversize, "D2" to specify .020" oversize. Ex.: AJB-4TFC-008D1 or AJB-4TFC-008D2.



GMM-M & GMB-M (MALE) and GMW-M & GMG-M (FEMALE) SERIES ROD ENDS

General Aviation - Precision

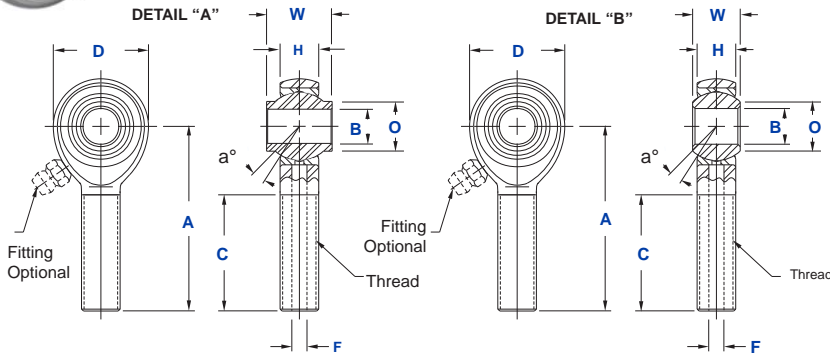

Specifications	
Body	Carbon Steel protective coated for corrosion resistance.
Ball	Alloy steel, Heat treated, Hard Chrome Plated (QQ C 320, Class 2).
Race	Carbon Steel, Protective Coated for Corrosion Resistance.

Units are traceable and magnetic particle inspected after assembly.
Load ratings apply only to rod ends without grease fittings. For load ratings with grease fittings, please consult our engineering department.

Rod End No.		DIMENSIONS IN INCHES											a°	Ultimate	Approx.
AURORA Part No.	Heim Part No.	Ball Shoulder Configuration	B +.0015 -.0005	W +.000 -.005	H ±.005	A ±.015	D ±.010	Shoulder Dia. Ref.	Ball Dia. Ref.	C Min.	F Drilled Hole Dia Ref.	Thread UNF-3A	Misalign. Angle	Radial Static Load Capacity	Brg. Wt. Lbs.
GMM-3M-470	M34-14M	See Detail "A"	.1900	.437	.281	1.562	.750	.315	.500	.969		1/4 28	17	2,158	.05
GMM-3M-570	MD35-14M	See Detail "A"	.1900	.437	.328	1.375	.875	.315	.500	.750	.113	5/16 24	10	2,823	.07
GMM-3M-670	MD36-14M	See Detail "A"	.1900	.437	.328	1.375	.750	.315	.500	.750	.113	3/8 24	10	2,850	.08
GMM-3M-680	MD36-16M	See Detail "B"	.1900	.500	.375	1.812	.833	.319	.593	1.062	.136	3/8 24	18	3,269	.09
GMM-4M-470	M44-14M	See Detail "B"	.2500	.437	.304	1.562	.812	.353	.562	.969		1/4 28	18	2,158	.07
GMM-4M-675	MD46-15M	See Detail "B"	.2500	.484	.335	2.312	.875	.395	.625	1.500	.136	3/8 24	18	3,160	.11
GMM-4M-680	MD46-16M	See Detail "B"	.2500	.500	.335	2.062	.875	.375	.625	1.500	.159	3/8 24	21	2,985	.10

Units are supplied without grease fittings. When grease fittings are required, specify by adding suffixes as designated.
Z Zerk type fitting Ex: GMM 3MZ 470 F Flush type fitting Ex: GMM 3MF 470

For left hand thread use the letter "B" in the prefix Ex: GMB-3M-470

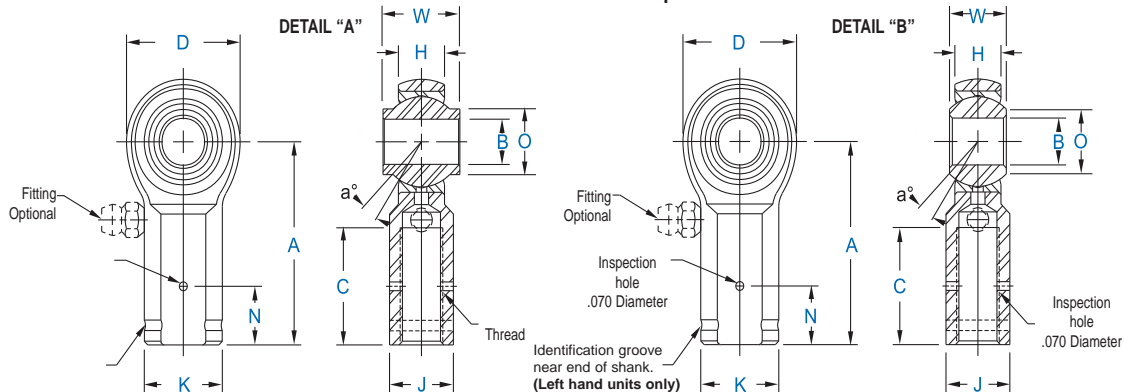

Rod End No.		DIMENSIONS IN INCHES													a°	Ultimate	Approx.
AURORA Part No.	Heim Part No.	Ball Shoulder Configuration	B +.0015 -.0005	W +.000 -.005	H ±.005	A ±.015	D ±.010	K ±.010	J ±.010	N ±.005	O Shoulder Dia. Ref.	Ball Dia. Ref.	C +.062 -.031	Thread UNF-3B	Misalign. Angle	Radial Static Load Capacity	Brg. Wt. Lbs.
GMW-3M-470	F34-14M	See Detail "A"	.1900	.437	.328	1.375	.750	.468	.375	.312	.315	.500	.750	1/4 28	10	2,881	.06
GMW-3M-471	F347-14M	See Detail "A"	.1900	.437	.328	1.062	.750	.375			.315	.500	.437	1/4 28	10	2,881	.05
GMW-3M-480	F34-16M	See Detail "A"	.1900	.500	.375	1.375	.812	.468	.375	.312	.312	.562	.750	1/4 28	15	3,152	.08
GMW-3M-570	F35-14M	See Detail "A"	.1900	.437	.328	1.375	.750	.500	.437	.312	.315	.500	.750	5/16 24	10	2,881	.07
GMW-4M-470	F44-14M	See Detail "B"	.2500	.437	.304	1.375	.812	.468	.437	.312	.353	.562	.750	1/4 28	18	2,950	.08
GMW-4M-595	F45-19M	See Detail "A"	.2500	.593	.406	1.469	.938	.500	.437	.312	.485	.687	.844	5/16 24	10	3,359	.10

Units are supplied without grease fittings. When grease fittings are required, specify by adding suffixes as designated.
Z Zerk type fitting Ex: GMW 3MZ 470 F Flush type fitting Ex: GMW 3MF 470

For left hand thread use the letter "G" in the prefix Ex: GMG-3M-470



MAJOR SPECIFICATION APPROVALS

For approval status to manufacturer specifications not listed.

MILITARY SPECIFICATIONS

AS14101	AS81935/1	AS81934/1
AS14102	AS81935/2	AS81934/2
AS14103		
AS14104		

BOEING SPECIFICATIONS

BACB10A	BACB10FH	BACB10HP	BACB10Y	60B10009
BACB10AB	BACB10FJ	BACB10HR	BACB10Z	60B10024
BACB10AG	BACB10GB	BACB10J	10-60516	60B50350
BACB10CL	BACB10GC	BACB10JA	10-60545	60B50351
BACB10CN	BACB10GD	BACB10JT	10-60779	60B80103
BACB10ER	BACB10HM	BACB10W	60B00180	S012T235
BACB10ES	BACB10HN	BACB10X	60B10007	S012T237
				162T4005

AIRBUS SPECIFICATIONS

ABS0569	ABS0570	ABS0571
---------	---------	---------

LOCKHEED SPECIFICATIONS

	<u>F-16</u>		<u>F-22</u>
C11653	C631	C7537	5VR40007
C20308	C633	C7546	5VR50103
C2959	C657	C7547	
C347	C658	C7937	
C555	C7504	C806	

F-35

JSFE03	JSFE17	JSFE31	JSFE46	JSFE61
JSFE04	JSFE19	JSFE32	JSFE47	JSFE62
JSFE05	JSFE20	JSFE34	JSFE48	JSFE63
JSFE09	JSFE22	JSFE35	JSFE50	JSFE65
JSFE11	JSFE23	JSFE36	JSFE51	JSFE67
JSFE12	JSFE24	JSFE37	JSFE52	JSFM23
JSFE13	JSFE25	JSFE39	JSFE53	JSFM62
JSFE14	JSFE26	JSFE43	JSFE55	JSFM64
JSFE15	JSFE27	JSFE44	JSFE57	
JSFE16	JSFE28	JSFE45	JSFE59	

TEXTRON AVIATION

CESSNA SPECIFICATIONS

S1104	S2321	S3313
S1105	S2409	S3315
S1106	S2410	S3415
S1107	S2426	S3469
S1108	S2901	S3482
S1581	S2902	S3963
S1819	S3057	S3985
S1820	S3058	S4306
S1823	S3059	0841211
S1866	S3060	0841212
S2009	S3071	7061315
S2015	S3212	7062210
S2022	S3264	7062301
S2049	S3266	

BEECHCRAFT SPECIFICATIONS

131553
131554
131765
131766
131881



Military Specifications Interchange Guide

Mil Spec	Aurora	AMPEP	FJG	Heim	Heim	Kamatics
AS14101	ANC-TG	11BNG	FMGN	NRRG	NEG	KR-CNG
AS14102	AWC-T	11BWZ	FMGB	WRR	WE	KR-CW
AS14103	AWC-TG	11BWG	FMGB-M	WRRG	WEG	KR-CWG
AS14104	ANC-T	11BNZ	FMGS	NRR	NE	KR-CN
AS81934/1	AJB-TA/TC	13BAZ/13BSZ	FBPA	PBRR	PBE	KRJ
AS81934/2	AJB-TFA/TFC	13BAF/13BSF	FBFA	FBRR	FBE	KRJ-UD
AS81935/1	ASM-T	12BMR	REM W M	MXJRR-AS	ME	KR-M
AS81935/2	ASW-T	12BFR	REF W M	FXJRR-AS	FE	KR-F
Mil Spec	NHBB	NMB	Rose	RBC/TDI	SARMA	Southwest
AS14101	ADB V(L)	HT-V	RNDG	NTG	XRE	SWKN-400
AS14102	ADW (L)	WHT	RWD	WT	XRL R	SWKR-401
AS14103	ADW V(L)	WHT-V	RWDG	WTG	XRL	SWKR-400
AS14104	ADB (L)	HT	RND	NT	XRL R	SWKN-401
AS81934/1	AD	AJ	BPD	06-382, 06-282	BPA	MBAA , MBSS
AS81934/2	ADLF	AJF	BFD	07-382, 07-282	BFA	MBAAF, MBSSF
AS81935/1	ADNE J	ANM		MT	UMJ/XRL	SWRKM-500
AS81935/2	AND J	ANF		FT	UFL/XRL	SWRKF-500

This is a guide, not a definitive interchange. Consult relevant manufacturers literature for full part numbers and specifications.

This does not imply current approval to listed specifications. Consult manufacturer or current Qualified for Procurement List for manufacturer and part number approval status

Aurora PTFE Liner Specifications

Liner Designation	AT1400	AT2100	AT2300	AT3200
Construction	PTFE/Dacron Laminate	PTFE/Fiberglass Weave	PTFE/Dacron Weave	PTFE/Nomex Laminate
Thickness (in.)	.011 .013	.010 .012	.013 .015	.014 .016
Temperature (°F)	65° to 350°	65° to 250°	65° to 250°	65° to 350°
Static Limit Load	80,000 PSI	60,000 PSI	60,000 PSI	80,000 PSI
Stiffness	Medium to High	Medium	Low	Medium to High
Typical Performance	37,500 PSI @±25° & 10 20 cpm .0045 wear max. @ 25,000 cycles	25,000 PSI @±25° & 10 20 cpm .0060 wear max. @ 5,000 cycles	Contact Aurora Engineering Department	37,500 PSI @±25° & 10 20 cpm .0045 wear max. @ 25,000 cycles
Dynamic Capabilities	Light to heavy, unidirectional or alternating loads. Low speed, intermittent to continuous misalignment, intermittent to continuous oscillation.	Light unidirectional loads. Low speed, intermittent to continuous misalignment, intermittent to continuous oscillation	Light to medium, alternating or reversing loads. Medium to High speed, intermittent to continuous misalignment, intermittent to continuous oscillation.	Light to heavy, unidirectional or alternating loads. Low speed, intermittent to continuous misalignment, intermittent to continuous oscillation.
Comments	Good multi purpose system	Excellent stick slip properties Usually recommended for high splash or underwater applications	Excellent stick slip properties Good vibratory conditions	Highest performance characteristics for all applications Qualified to SAE AS81820



Additional Products

In addition to the products featured in this publication, Aurora Bearing Company features the most diverse range of commercial and high performance rod end and spherical bearings in the industry. From economy commercial to high performance bearings for motorsports, Aurora has product solutions for the most demanding motion transfer needs. Sizes from 1/8" to 2", metric 3 - 30mm available. Further, many of these product lines are available with full traceability and/or magnetic particle inspection for aerospace applications, and are frequently used as such in the aerospace industry.



Beyond the Aurora standard Aircraft and Commercial catalog offerings, Aurora Bearing has the capability to design, engineer, and manufacture special bearings and linkage assemblies. Illustrated below is just a sample of items produced for aerospace (L) and commercial industrial (C & R) customers.

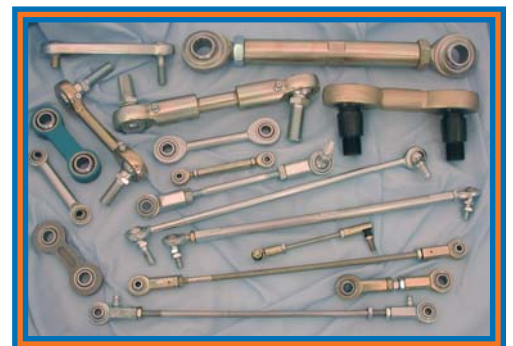
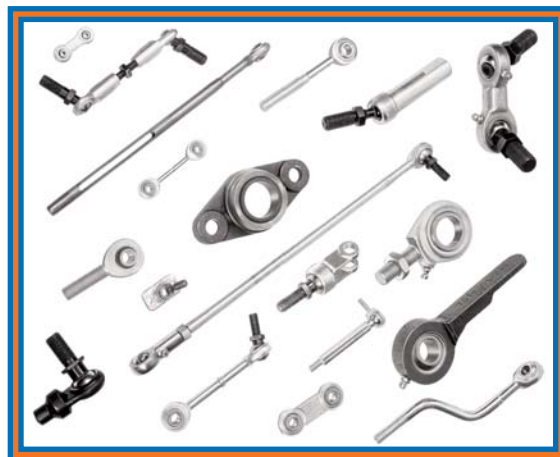



ULTIMATE RADIAL STATIC LOAD CAPACITY ROD ENDS

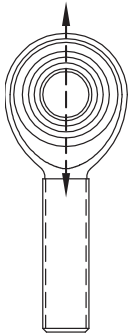

The ultimate radial static load capacity is based upon the minimum mechanical properties of the design configuration in the stressed area. The ultimate radial static load capacity called out in the rod end specification charts is defined as a single cycle, unidirectional applied load to cause ultimate failure. Operating loads should be based on the static load ratings, incorporating appropriate safety factors to suit the application. When a rod end is to be applied in full rotation, the surface speed of the ball should be kept below 20 feet per minute or the rotational speed should be below 100 RPM, whichever is lower, with the operating loads not to exceed 10% of the ultimate radial static load.

Load ratings listed in the standard detail pages are applicable to rod ends supplied without grease fittings. Load ratings for units employing fittings may be affected due to lighter cross section in the stressed area.

For information on the rod end radial static load ratings with fittings and other specific load rating information, consult the Aurora Bearing engineering department.

AXIAL STATIC LOAD CAPACITY ROD ENDS

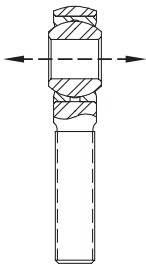

Axial static load capacity is the force that is applied through the bore of the ball. For Aurora two-piece rod ends, maximum axial static load capacity is recommended to be 15 percent of the ultimate radial static load capacity. For three-piece rod ends, maximum axial static load capacity is generally recommended as 10 percent of ultimate radial static load capacity. It should be noted, however, that on three-piece units factors such as race material, body material and dimensions may affect axial static load capacity. For further information, consult the Aurora Bearing engineering department.

RADIAL STATIC LIMIT LOAD CAPACITY SPHERICAL BEARINGS

Radial static limit loads are maximum static based on the maximum permanent set in the bearing race of 0.2% of the ball diameter. If greater permanent set can be allowed or if alternate race materials are used consult our engineering department for change factors. Operating loads are based on the radial static limit load rating and appropriate safety factors should be utilized to suit the application.

Max axial load is recommended at 20 percent of the radial static load. Extreme care should be used on selecting a sufficiently strong housing to accept this type of bearing.

BEARING MISALIGNMENT

A rod end or spherical bearing's ability to misalign is measured by the degree of angle the ball can accommodate without interference.

The angle of misalignment in a rod end is limited by the ball width and head diameter as shown in figure 1. This arrangement is called a clevis mount, and is the type represented in the standard rod end detail pages. If added misalignment is necessary, this can be accomplished by utilizing spacers between the clevis mounting and ball face, or by using special rod ends designed to meet specific requirements.

Misalignment angle in a spherical bearing is limited by the ball and race width with respect to the ball diameter, illustrated in figure 3. This is the mounting type represented in the standard detail pages for spherical bearings.

Mounting arrangements for spherical bearings such as shown in figures 2 through 4 are also used with rod ends. The misalignment angle is then calculated by selecting the proper formula below.

ANGLE OF MISALIGNMENT

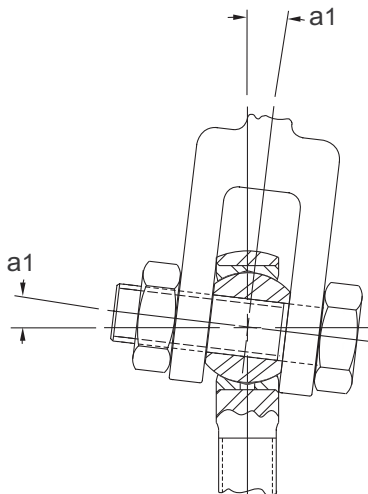

FIGURE 1
 $a1 = \sin^{-1} \frac{W}{D} \sin^{-1} \frac{H}{D}$

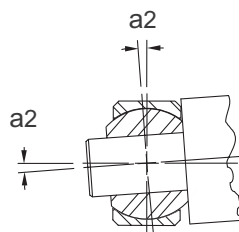

FIGURE 2
 $a2 = \sin^{-1} \frac{W}{A} \sin^{-1} \frac{H}{A}$

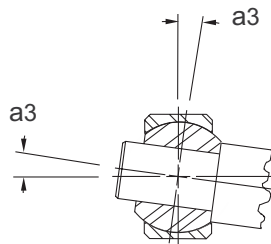

FIGURE 3
 $a3 = \sin^{-1} \frac{W}{R} \sin^{-1} \frac{H}{R}$

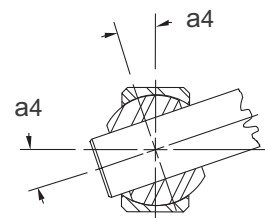

FIGURE 4
 $a4 = \cos^{-1} \frac{B}{R} \sin^{-1} \frac{H}{R}$

Reference Letters

- B Ball Bore
- M Outer Race Chamfer
- D Head Diameter of Outer Race Diameter

- R Ball Diameter
- H Housing Width
- A $\sqrt{(D - 2M)^2 + H^2}$
- W Ball Width

3-Piece Unit

HOUSING

Chamfers on both sides

NOTE - Re-Lube hole for lubrication through shank of housing.

INSERT

Consists of BALL and RACE

Single piece race, steel, heat-treated (optional), features swaged construction for maximum performance. Alternate race materials available to suit your application.

ASSEMBLED HOUSING AND INSERT IN PRE-STAKING POSITION

Note extension of race beyond width of housing in the pre-staking position.

ASSEMBLED HOUSING AND INSERT IN STAKED POSITION

After staking, the sides of race have been upset into chamfers. Ball is subsequently loosened holding close tolerance fits between ball and race.

2-Piece Unit

Housing ready for swaging

Precision ground ball - (available in alternate materials) - for close tolerance fits.

Housing and Ball in pre-swaging position.

Sides of housing are closed around ball for maximum strength unit.



SPM & SPB SERIES MALE ROD ENDS

Molded Race – Economy

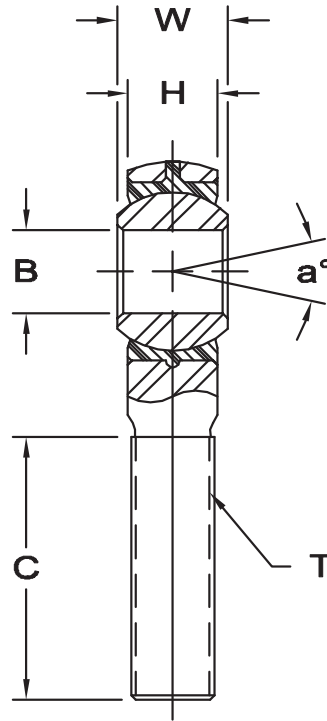
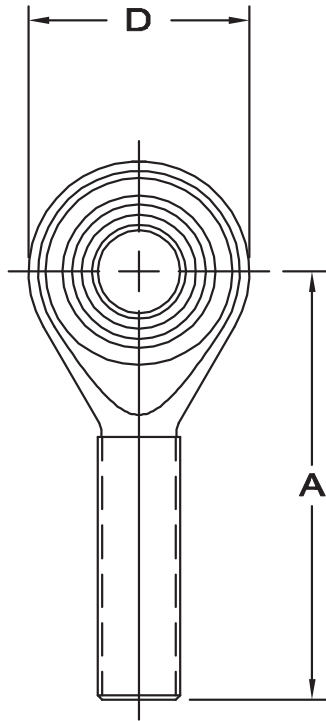

Clevis Mounted

Body - Low carbon steel, protective coated for corrosion resistance.

Ball - Alloy steel, heat treated, hard chrome plated.

Race - Molded, self-lubricating, reinforced Nylon.

Thread

This series features a molded race compound designed to provide low friction, low moisture absorbing properties.

This series is also available in a studed configuration. Specify by adding suffix "S." Ex: SPM 8S

ROD END NO.		DIMENSIONS IN INCHES								a° Misalign. Angle	Ultimate Radial Static Load Capacity Lbs.	Approx. Brg. Wt. Lbs.
Right Hand	Left Hand	B + .0020 -.0000	W ± .005	H Ref.	A + .060 -.030	D ± .015	Ball Dia. Ref.	C ± .062	Thread UNF-2A			
SPM-3	SPB-3	.1900	.312	.250	1.250	.625	.437	.750	10 32	13	1,210	.02
SPM-4	SPB-4	.2500	.375	.281	1.562	.750	.500	1.000	1/4 28	16	2,470	.04
SPM-5	SPB-5	.3125	.437	.344	1.875	.875	.625	1.250	5/16 24	14	2,740	.07
SPM-6	SPB-6	.3750	.500	.406	1.938	1.000	.719	1.250	3/8 24	12	4,210	.11
SPM-7	SPB-7	.4375	.562	.437	2.125	1.125	.812	1.312	7/16 20	14	5,350	.15
SPM-8	SPB-8	.5000	.625	.500	2.438	1.312	.937	1.500	1/2 20	12	6,430	.23
SPM-10	SPB-10	.6250	.750	.562	2.625	1.500	1.125	1.625	5/8 18	16	8,300	.36
SPM-12	SPB-12	.7500	.875	.687	2.875	1.750	1.312	1.750	3/4 16	14	10,900	.57

ROD END NO.		DIMENSIONS IN MILLIMETERS								a° Misalign. Angle	Ultimate Radial Static Load Capacity Newtons	Approx. Brg. Wt. Grams
Right Hand	Left Hand	B + .051 -.000	W ± .13	H Ref.	A + 1.52 -.76	D ± .38	Ball Dia. Ref.	C ± 1.57	Thread UNF-2A			
SPM-3	SPB-3	4.826	7.92	6.35	31.75	15.88	11.10	19.05	10 32	13	5,382	10
SPM-4	SPB-4	6.350	9.53	7.14	39.67	19.05	12.70	25.40	1/4 28	16	10,987	18
SPM-5	SPB-5	7.938	11.10	8.74	47.63	22.23	15.88	31.75	5/16 24	14	12,188	32
SPM-6	SPB-6	9.525	12.70	10.31	49.23	25.40	18.26	31.75	3/8 24	12	18,726	49
SPM-7	SPB-7	11.113	14.27	11.10	53.98	28.58	20.62	33.33	7/16 20	14	23,797	67
SPM-8	SPB-8	12.700	15.88	12.70	61.93	33.32	23.80	38.10	1/2 20	12	28,601	105
SPM-10	SPB-10	15.875	19.05	14.27	66.68	38.10	28.58	41.28	5/8 18	16	36,918	165
SPM-12	SPB-12	19.050	22.23	17.45	73.03	44.45	33.32	44.45	3/4 16	14	48,483	258

SPW & SPG SERIES FEMALE ROD ENDS

Molded Race – Economy



Body - Low carbon steel, protective coated for corrosion resistance.

Ball - Alloy steel, heat treated, hard chrome plated.

Race - Molded, self-lubricating, reinforced Nylon.

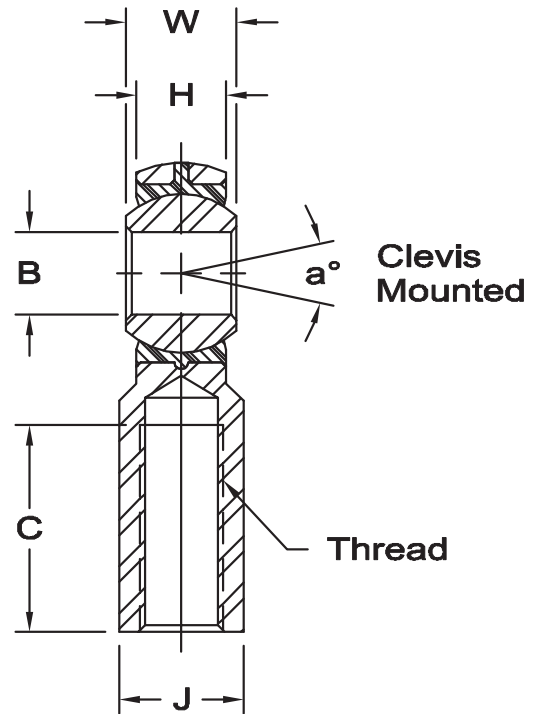
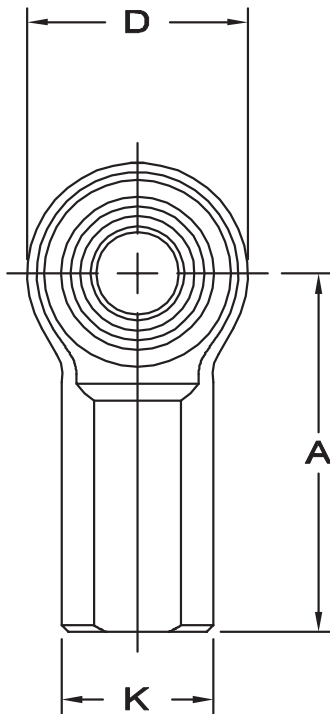

This series features a molded race compound designed to provide low friction, low moisture absorbing properties.

This series is also available in a studed configuration. Specify by adding suffix "S." Ex: SPW 8S

ROD END NO.		DIMENSIONS IN INCHES										a° Misalign. Angle	Ultimate Radial Static Load Capacity Lbs.	Approx. Brg. Wt. Lbs.
Right Hand	Left Hand	B + .0020 -.0000	W ± .005	H Ref.	A + .060 -.030	D ± .015	K ± .015	J ± .015	Ball Dia. Ref.	C ± .062	Thread UNF-2B			
SPW-3	SPG-3	.1900	.312	.250	1.062	.625	.406	.312	.437	.562	10 32	13	1,210	.04
SPW-4	SPG-4	.2500	.375	.281	1.312	.750	.469	.375	.500	.750	1/4 28	16	2,470	.06
SPW-5	SPG-5	.3125	.437	.344	1.375	.875	.500	.437	.625	.750	5/16 24	14	2,740	.08
SPW-6	SPG-6	.3750	.500	.406	1.625	1.000	.687	.562	.719	.937	3/8 24	12	4,100	.15
SPW-7	SPG-7	.4375	.562	.437	1.812	1.125	.750	.625	.812	1.062	7/16 20	14	5,350	.19
SPW-8	SPG-8	.5000	.625	.500	2.125	1.312	.875	.750	.937	1.187	1/2 20	12	6,430	.31
SPW-10	SPG-10	.6250	.750	.562	2.500	1.500	1.000	.875	1.125	1.500	5/8 18	16	8,300	.46
SPW-12	SPG-12	.7500	.875	.687	2.875	1.750	1.125	1.000	1.312	1.562	3/4 16	14	10,900	.67

ROD END NO.		DIMENSIONS IN MILLIMETERS										a° Misalign. Angle	Ultimate Radial Static Load Capacity Newtons	Approx. Brg. Wt. Grams
Right Hand	Left Hand	B + .051 -.000	W ± .13	H Ref.	A + 1.52 -.76	D ± .38	K ± .38	J ± .38	Ball Dia. Ref.	C ± 1.57	Thread UNF-2B			
SPW-3	SPG-3	4.826	7.92	6.35	26.97	15.88	10.31	7.92	11.10	14.27	10 32	13	5,382	17
SPW-4	SPG-4	6.350	9.53	7.14	33.32	19.05	11.91	9.53	12.70	19.05	1/4 28	16	10,987	27
SPW-5	SPG-5	7.938	11.10	8.74	34.93	22.23	12.70	11.10	15.88	19.05	5/16 24	14	12,188	35
SPW-6	SPG-6	9.525	12.70	10.31	41.28	25.40	17.45	14.27	18.26	23.80	3/8 24	12	18,237	66
SPW-7	SPG-7	11.113	14.27	11.10	46.02	28.58	19.05	15.88	20.62	26.97	7/16 20	14	23,797	87
SPW-8	SPG-8	12.700	15.88	12.70	53.98	33.32	22.23	19.05	23.80	30.15	1/2 20	12	28,601	142
SPW-10	SPG-10	15.875	19.05	14.27	63.50	38.10	25.40	22.23	28.58	38.10	5/8 18	16	36,918	210
SPW-12	SPG-12	19.050	22.23	17.45	73.03	44.45	28.58	25.40	33.32	44.45	3/4 12	14	48,483	305



CM & CB SERIES MALE ROD ENDS

General Purpose - Economy

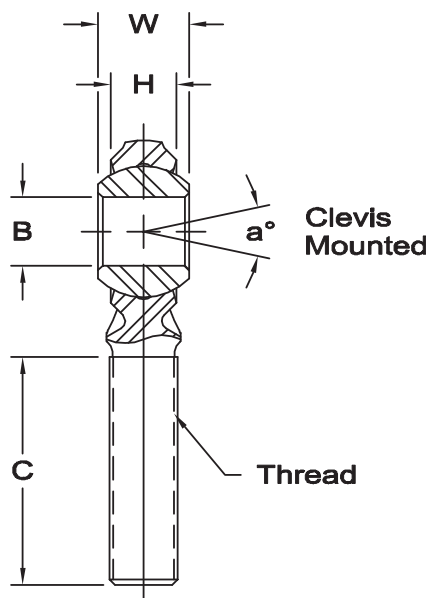
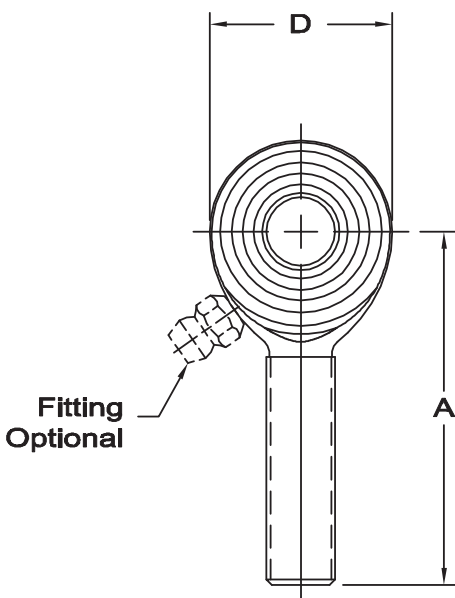

Body - Low carbon steel, protective coated for corrosion resistance.

Ball - Alloy steel, heat treated, hard chrome plated.

Load ratings apply only to rod ends without grease fittings. For load ratings with fittings, please consult our engineering department.

* Grease fittings not available on these sizes. Units are supplied without grease fittings. When a grease fitting is required, specify by adding suffix as designated.
 Z Zerk type fitting Ex: CM 6Z
 F Flush type fitting Ex: CM 6F

ROD END NO.		DIMENSIONS IN INCHES								a° Misalign. Angle	Ultimate Radial Static Load Capacity Lbs.	Approx. Brg. Wt. Lbs.
Right Hand	Left Hand	B + .0025 - .0005	W ± .005	H Ref.	A ± .015	D Ref.	Ball Dia. Ref.	C + .062 - .031	Thread UNF-3A			
CM-3*	CB-3*	.1900	.312	.234	1.250	.625	.437	.750	10 32	20	1,204	.03
CM-4*	CB-4*	.2500	.375	.250	1.562	.750	.500	1.000	1/4 28	27	2,212	.04
CM-5*	CB-5*	.3125	.437	.312	1.875	.875	.625	1.250	5/16 24	22	3,577	.07
CM-6	CB-6	.3750	.500	.359	1.938	1.000	.719	1.250	3/8 24	22	5,068	.11
CM-7	CB-7	.4375	.562	.406	2.125	1.125	.812	1.375	7/16 20	21	6,345	.15
CM-8	CB-8	.5000	.625	.453	2.438	1.312	.937	1.500	1/2 20	20	8,338	.24
CM-10	CB-10	.6250	.750	.484	2.625	1.500	1.125	1.625	5/8 18	26	9,713	.36
CM-12	CB-12	.7500	.875	.593	2.875	1.750	1.312	1.750	3/4 16	24	14,207	.57

ROD END NO.		DIMENSIONS IN MILLIMETERS								a° Misalign. Angle	Ultimate Radial Static Load Capacity Newtons	Approx. Brg. Wt. Grams
Right Hand	Left Hand	B + .064 - .013	W ± .13	H Ref.	A ± .38	D Ref.	Ball Dia. Ref.	C + 1.57 - .79	Thread UNF-3A			
CM-3*	CB-3*	4.826	7.92	5.94	31.75	15.88	11.10	19.05	10 32	20	5,355	14
CM-4*	CB-4*	6.350	9.53	6.35	39.67	19.05	12.70	25.40	1/4 28	27	9,839	18
CM-5*	CB-5*	7.938	11.10	7.92	47.63	22.23	15.88	31.75	5/16 24	22	15,910	32
CM-6	CB-6	9.525	12.70	9.12	49.23	25.40	18.26	31.75	3/8 24	22	22,542	50
CM-7	CB-7	11.113	14.27	10.31	53.98	28.58	20.62	34.93	7/16 20	21	28,223	68
CM-8	CB-8	12.700	15.88	11.50	61.93	33.32	23.80	38.10	1/2 20	20	37,087	109
CM-10	CB-10	15.875	19.05	12.29	66.68	38.10	28.58	41.28	5/8 18	26	43,203	163
CM-12	CB-12	19.050	22.23	15.06	73.03	44.45	33.32	44.45	3/4 16	24	63,193	259

CW & CG SERIES FEMALE ROD ENDS

General Purpose - Economy



Body - Low carbon steel, protective coated for corrosion resistance.

Ball - Alloy steel, heat treated, hard chrome plated.

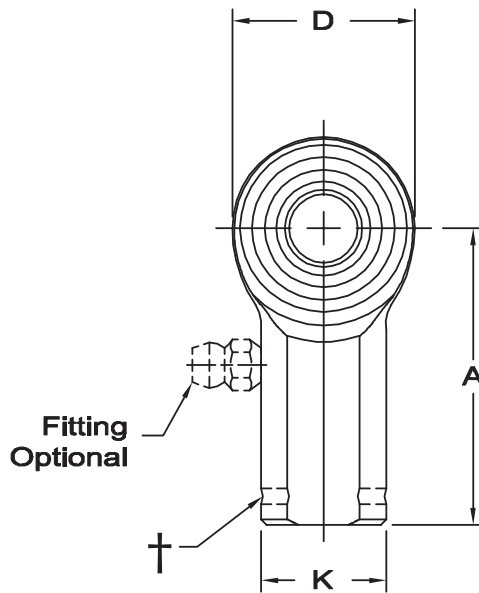

Fitting
Optional

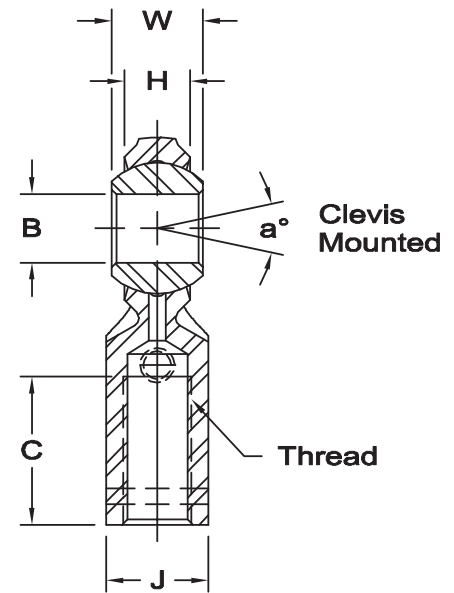

Clevis
Mounted

Thread

†Left hand units have identification groove near end of shank.

* Grease fittings not available on these sizes. Units are supplied without grease fittings. When a grease fitting is required, specify by adding suffix as designated.

Z Zerk type fitting
F Flush type fitting

Ex: CW 6Z
Ex: CW 6F

ROD END NO.		DIMENSIONS IN INCHES										a° Misalign. Angle	Ultimate Radial Static Load Capacity Lbs.	Approx. Brg. Wt. Lbs.
Right Hand	Left Hand†	B + .0025 -.0005	W ± .005	H Ref.	A ± .015	D Ref.	K ± .010	J ± .010	Ball Dia. Ref.	C + .062 -.031	Thread UNF-2B			
CW-3*	CG-3*	.1900	.312	.234	1.062	.625	.406	.312	.437	.500	10 32	20	2,079	.04
CW-4	CG-4	.2500	.375	.250	1.312	.750	.469	.375	.500	.687	1/4 28	27	3,208	.05
CW-5	CG-5	.3125	.437	.312	1.375	.875	.500	.437	.625	.687	5/16 24	22	3,824	.08
CW-6	CG-6	.3750	.500	.359	1.625	1.000	.687	.562	.719	.812	3/8 24	22	5,087	.13
CW-7	CG-7	.4375	.562	.406	1.812	1.125	.750	.625	.812	.937	7/16 20	21	6,385	.18
CW-8	CG-8	.5000	.625	.453	2.125	1.312	.875	.750	.937	1.062	1/2 20	20	9,096	.29
CW-10	CG-10	.6250	.750	.484	2.500	1.500	1.000	.875	1.125	1.375	5/8 18	26	9,713	.43
CW-12	CG-12	.7500	.875	.593	2.875	1.750	1.125	1.000	1.312	1.562	3/4 16	24	14,207	.65

ROD END NO.		DIMENSIONS IN MILLIMETERS										a° Misalign. Angle	Ultimate Radial Static Load Capacity Newtons	Approx. Brg. Wt. Grams
Right Hand	Left Hand†	B + .064 -.013	W ± .13	H Ref.	A ± .38	D Ref.	K ± .25	J ± .25	Ball Dia. Ref.	C + 1.57 -.79	Thread UNF-2B			
CW-3*	CG-3*	4.826	7.92	5.94	26.97	15.88	10.31	7.92	11.10	12.70	10 32	20	9,247	18
CW-4	CG-4	6.350	9.53	6.35	33.32	19.05	11.91	9.53	12.70	17.45	1/4 28	27	14,269	23
CW-5	CG-5	7.938	11.10	7.92	34.93	22.23	12.70	11.10	15.88	17.45	5/16 24	22	17,009	36
CW-6	CG-6	9.525	12.70	9.12	41.28	25.40	17.45	14.27	18.26	20.62	3/8 24	22	22,627	59
CW-7	CG-7	11.113	14.27	10.31	46.02	28.58	19.05	15.88	20.62	23.80	7/16 20	21	28,400	82
CW-8	CG-8	12.700	15.88	11.50	53.98	33.32	22.23	19.05	23.80	26.97	1/2 20	20	40,459	132
CW-10	CG-10	15.875	19.05	12.29	63.50	38.10	25.40	22.23	28.58	34.93	5/8 18	26	43,203	195
CW-12	CG-12	19.050	22.23	15.06	73.03	44.45	28.58	25.40	33.32	39.67	3/4 16	24	63,193	295



VCM & VCB SERIES MALE ROD ENDS

General Purpose - Economy - Self-Lubricating

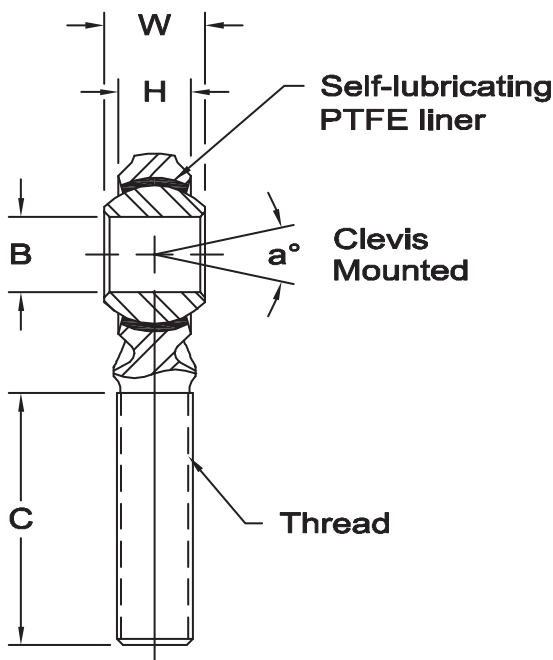
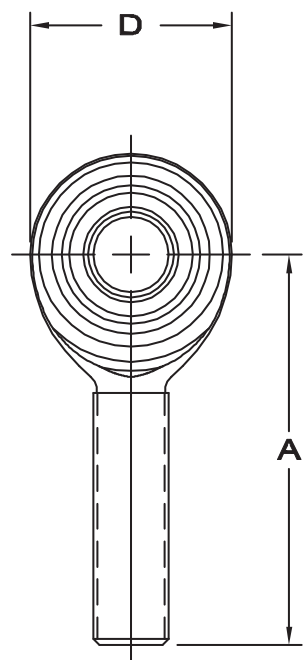

Body - Low carbon steel, protective coated for corrosion resistance.

Ball - Alloy steel, heat treated, hard chrome plated.

Bushing - Steel Backed, PTFE Composite

ROD END NO.		DIMENSIONS IN INCHES								a° Misalign. Angle	Ultimate Radial Static Load Capacity Lbs.	Approx. Brg. Wt. Lbs.
Right Hand	Left Hand	B +.0025 -.0005	W ± .005	H Ref.	A ± .015	D Ref.	Ball Dia. Ref.	C +.062 -.031	Thread UNF-3A			
VCM-5	VCB-5	.3125	.437	.312	1.875	.875	.593	1.250	5/16 24	18	2,623	.07
VCM-6	VCB-6	.3750	.500	.359	1.938	1.000	.687	1.250	3/8 24	18	3,643	.11
VCM-7	VCB-7	.4375	.562	.406	2.125	1.125	.781	1.375	7/16 20	17	4,464	.15
VCM-8	VCB-8	.5000	.625	.453	2.438	1.312	.875	1.500	1/2 20	16	7,229	.24
VCM-10	VCB-10	.6250	.750	.484	2.625	1.500	1.062	1.625	5/8 18	22	8,204	.36
VCM-12	VCB-12	.7500	.875	.593	2.875	1.750	1.250	1.750	3/4 16	20	12,280	.57

ROD END NO.		DIMENSIONS IN MILLIMETERS								a° Misalign. Angle	Ultimate Radial Static Load Capacity Newtons	Approx. Brg. Wt. Grams
Right Hand	Left Hand	B +.064 -.013	W ± .13	H Ref.	A ± .38	D Ref.	Ball Dia. Ref.	C + 1.57 -.79	Thread UNF-3A			
VCM-5	VCB-5	7.938	11.10	7.92	47.63	22.23	15.06	31.75	5/16 24	18	11,667	32
VCM-6	VCB-6	9.525	12.70	9.12	49.23	25.40	17.45	31.75	3/8 24	18	16,204	50
VCM-7	VCB-7	11.113	14.27	10.31	53.98	28.58	19.84	34.93	7/16 20	17	19,856	68
VCM-8	VCB-8	12.700	15.88	11.50	61.93	33.32	22.23	38.10	1/2 20	16	32,155	109
VCM-10	VCB-10	15.875	19.05	12.29	66.68	38.10	26.97	41.28	5/8 18	22	36,491	163
VCM-12	VCB-12	19.050	22.23	15.06	73.03	44.45	31.75	44.45	3/4 16	20	54,621	259

VCW & VCG SERIES FEMALE ROD ENDS

General Purpose - Economy - Self-Lubricating



Body - Low carbon steel, protective coated for corrosion resistance.

Ball - Alloy steel, heat treated, hard chrome plated.

Bushing - Steel Backed, PTFE Composite

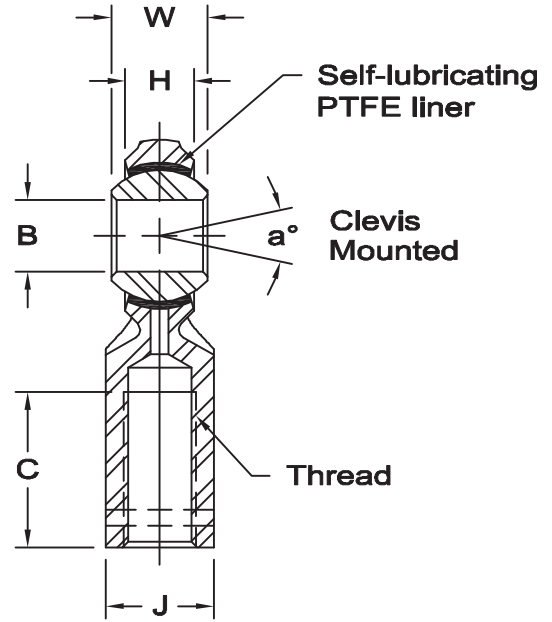
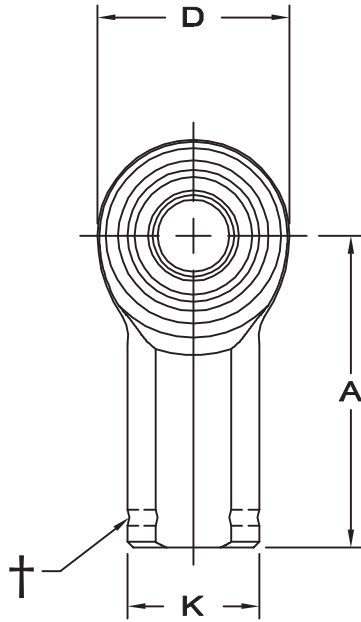

†Left hand units have identification groove near end of shank.

ROD END NO.		DIMENSIONS IN INCHES										a° Misalign. Angle	Ultimate Radial Static Load Capacity Lbs.	Approx. Brg. Wt. Lbs.
Right Hand	Left Hand†	B + .0025 -.0005	W ± .005	H Ref.	A ± .015	D Ref.	K ± .010	J ± .010	Ball Dia. Ref.	C + .062 -.031	Thread UNF-2B			
VCW-5	VCG-5	.3125	.437	.312	1.375	.875	.500	.437	.593	.687	5/16 24	18	2,623	.08
VCW-6	VCG-6	.3750	.500	.359	1.625	1.000	.687	.562	.687	.812	3/8 24	18	3,643	.13
VCW-7	VCG-7	.4375	.562	.406	1.812	1.125	.750	.625	.781	.937	7/16 20	17	4,464	.18
VCW-8	VCG-8	.5000	.625	.453	2.125	1.312	.875	.750	.875	1.062	1/2 20	16	7,229	.29
VCW-10	VCG-10	.6250	.750	.484	2.500	1.500	1.000	.875	1.062	1.375	5/8 18	22	8,204	.43
VCW-12	VCG-12	.7500	.875	.593	2.875	1.750	1.125	1.000	1.250	1.562	3/4 16	20	12,280	.65

ROD END NO.		DIMENSIONS IN MILLIMETERS										a° Misalign. Angle	Ultimate Radial Static Load Capacity Newtons	Approx. Brg. Wt. Grams
Right Hand	Left Hand†	B + .064 -.013	W ± .13	H Ref.	A ± .38	D Ref.	K ± .25	J ± .25	Ball Dia. Ref.	C + 1.57 -.79	Thread UNF-2B			
VCW-5	VCG-5	7.938	11.10	7.92	34.93	22.23	12.70	11.10	15.06	17.45	5/16 24	18	11,667	36
VCW-6	VCG-6	9.525	12.70	9.12	41.28	25.40	17.45	14.27	17.45	20.62	3/8 24	18	16,204	59
VCW-7	VCG-7	11.113	14.27	10.31	46.02	28.58	19.05	15.88	19.84	23.80	7/16 20	17	19,856	82
VCW-8	VCG-8	12.700	15.88	11.50	53.98	33.32	22.23	19.05	22.23	26.97	1/2 20	16	32,155	132
VCW-10	VCG-10	15.875	19.05	12.29	63.50	38.10	25.40	22.23	26.97	34.93	5/8 18	22	36,491	195
VCW-12	VCG-12	19.050	22.23	15.06	73.03	44.45	28.58	25.40	31.75	39.67	3/4 16	20	54,621	295



MM & MB SERIES MALE ROD ENDS

General Purpose - Precision (PTFE Liners Available)

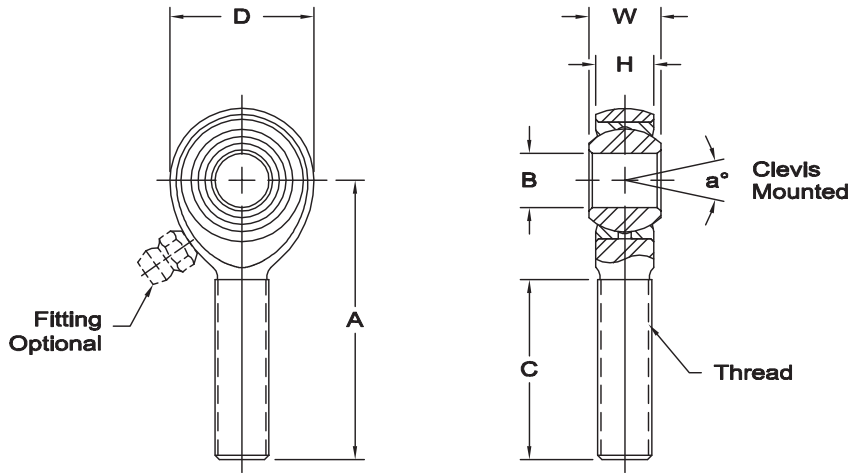

Body - Carbon steel protective coated for corrosion resistance. No. 16 series standard body is alloy steel not heat treated.

Race - Carbon steel, protective coated for corrosion resistance.

Ball - Alloy steel, heat treated, hard chrome plated.

Notes - All sizes available with studs upon request.



- * Check availability.
- ** Grease fitting not available.
- 1 Threads 6 32 UNC.
- 2 Threads 1 14 UNS.
- 3 Tolerance variation: "D" ± .020, "A" ± .020, "B" + .0035, -.0005, "H" ± .010
- 4 Tolerance variation: "D" ± .51, "A" ± .51, "B" + .089, -.013, "H" ± .25

Units are supplied without grease fittings. When grease fittings are required, specify by adding suffixes as designated.

- Z Zerk type fitting Ex: MM 6Z
- F Flush type fitting Ex: MM 6F
- T PTFE liner Ex: MM 6T

Load ratings apply only to rod ends without grease fittings. For load ratings with fittings, please consult our engineering department.

ROD END NO.		DIMENSIONS IN INCHES								a° Misalign. Angle	Ultimate Radial Static Load Capacity Lbs.	Approx. Brg. Wt. Lbs.	
Right Hand	Left Hand	B + .0015 - .0005	W + .000 - .005	H ± .005	A ± .015	D ± .010	Ball Dia. Ref.	C + .062 - .031	Thread UNF-3A				
**	MM-2	MB-2	.1250	.250	.187	.937	.500	.312	.562	6 32 ₁	16	502	.01
	MM-3	MB-3	.1900	.312	.250	1.250	.625	.437	.750	10 32	13	1,169	.03
	MM-4	MB-4	.2500	.375	.281	1.562	.750	.500	1.000	1/4 28	16	2,158	.04
	MM-5	MB-5	.3125	.437	.344	1.875	.875	.625	1.250	5/16 24	14	2,784	.07
	MM-6	MB-6	.3750	.500	.406	1.938	1.000	.719	1.250	3/8 24	12	3,915	.11
	MM-7	MB-7	.4375	.562	.437	2.125	1.125	.812	1.375	7/16 20	14	4,218	.16
	MM-8	MB-8	.5000	.625	.500	2.438	1.312	.937	1.500	1/2 20	12	6,660	.25
	MM-10	MB-10	.6250	.750	.562	2.625	1.500	1.125	1.625	5/8 18	16	7,364	.38
	MM-12	MB-12	.7500	.875	.687	2.875	1.750	1.312	1.750	3/4 16	14	11,518	.60
*	MM-14	MB-14	.8750	.875	.765	3.375	2.000	1.375	2.000	7/8 14	7	18,476	.91
*	MM-14-1	MB-14-1	.8750	.875	.687	3.375	2.000	1.312	1.875	7/8 14	12	22,843	.91
3	MM-16	MB-16	1.0000	1.375	1.000	4.125	2.750	1.875	2.125	1 1/4 12	17	43,541	2.41
3	MM-16-1	MB-16-1	1.0000	1.375	1.000	4.125	2.750	1.875	2.125	1 1/4 ₂	17	43,541	2.13
3	MM-16-2	MB-16-2	1.0000	1.375	1.000	4.125	2.750	1.875	2.125	1 12	17	43,541	2.13

ROD END NO.		DIMENSIONS IN MILLIMETERS								a° Misalign. Angle	Ultimate Radial Static Load Capacity Newtons	Approx. Brg. Wt. Grams	
Right Hand	Left Hand	B + .038 - .013	W + .00 - .13	H ± .13	A ± .38	D ± .25	Ball Dia. Ref.	C + 1.57 - .79	Thread UNF-3A				
**	MM-2	MB-2	3.175	6.35	4.75	23.80	12.70	7.92	14.27	6 32 ₁	16	2,236	6
	MM-3	MB-3	4.826	7.92	6.35	31.75	15.88	11.10	19.05	10 32	13	5,197	13
	MM-4	MB-4	6.350	9.53	7.14	39.67	19.05	12.70	25.40	1/4 28	16	9,600	20
	MM-5	MB-5	7.938	11.10	8.74	47.63	22.23	15.88	31.75	5/16 24	14	12,385	33
	MM-6	MB-6	9.525	12.70	10.31	49.23	25.40	18.26	31.75	3/8 24	12	17,416	51
	MM-7	MB-7	11.113	14.27	11.10	53.98	28.58	20.62	34.93	7/16 20	14	18,759	73
	MM-8	MB-8	12.700	15.88	12.70	61.93	33.32	23.80	38.10	1/2 20	12	29,624	113
	MM-10	MB-10	15.875	19.05	14.27	66.68	38.10	28.58	41.28	5/8 18	16	32,752	173
	MM-12	MB-12	19.050	22.23	17.45	73.03	44.45	33.32	44.45	3/4 16	14	51,237	273
*	MM-14	MB-14	22.225	22.23	19.43	85.73	50.80	34.93	50.80	7/8 14	7	82,185	411
*	MM-14-1	MB-14-1	22.225	22.23	17.45	85.73	50.80	33.32	47.63	7/8 14	12	101,601	411
4	MM-16	MB-16	25.400	34.93	25.40	104.78	69.85	47.63	53.98	1 1/4 12	17	193,670	1,091
4	MM-16-1	MB-16-1	25.400	34.93	25.40	104.78	69.85	47.63	53.98	1 1/4 ₂	17	193,670	965
4	MM-16-2	MB-16-2	25.400	34.93	25.40	104.78	69.85	47.63	53.98	1 12	17	193,670	965

MW & MG SERIES FEMALE ROD ENDS

General Purpose - Precision (PTFE Liners Available)



Body - Carbon steel protective coated for corrosion resistance. No. 16 series standard body is alloy steel not heat treated.

Race - Carbon steel, protective coated for corrosion resistance.

Ball - Alloy steel, heat treated, hard chrome plated.

Notes - All sizes available with studs upon request.

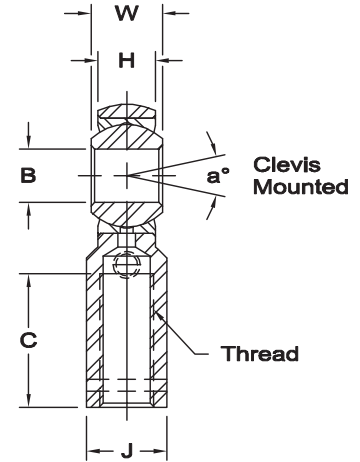
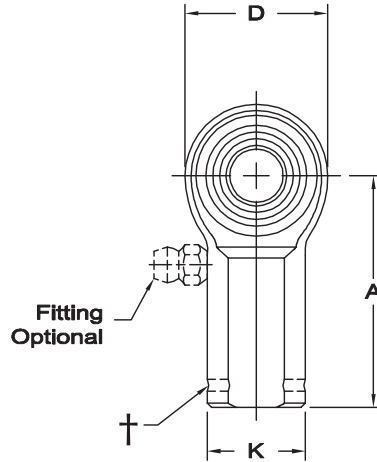

† Left hand units have identification groove near end of shank

1 Threads 6 32 UNC

2 Threads 1 14 UNS

3 Tolerance variation: "D" ± .020, "A" ± .020 "B" + .0035, .0005, "H" ± .010, "K" ± .015, "J" ± .015

4 Tolerance variation: "D" ± .51, "A" ± .51 "B" + .089, .013, "H" ±.25, "K" ± .38, "J" ± .38

** Grease fitting not available. Units are supplied without grease fittings. When a grease fitting is required, specify by adding suffix as designated.

Z Zerk type fitting

Ex: MW 6Z

F Flush type fitting

Ex: MW 6F

T PTFE liner

Ex: MW 6T

ROD END NO.		DIMENSIONS IN INCHES										a° Misalign. Angle	Ultimate Radial Static Load Capacity Lbs.	Approx. Brg. Wt. Lbs.	
Right Hand	Left Hand†	B + .0015 - .0005	W + .000 - .005	H ± .005	A ± .015	D ± .010	K ± .010	J ± .010	Ball Dia. Ref.	C + .062 - .031	Thread UNF-2B				
**	MW-2	MG-2	.1250	.250	.187	.812	.500	.312	.250	.312	.437	6 32 ₁	16	1,202	.02
	MW-3	MG-3	.1900	.312	.250	1.062	.625	.406	.312	.437	.562	10 32	13	1,531	.04
	MW-4	MG-4	.2500	.375	.281	1.312	.750	.469	.375	.500	.750	1/4 28	16	2,539	.06
	MW-5	MG-5	.3125	.437	.344	1.375	.875	.500	.437	.625	.750	5/16 24	14	3,133	.09
	MW-6	MG-6	.3750	.500	.406	1.625	1.000	.687	.562	.719	.937	3/8 24	12	3,915	.15
	MW-7	MG-7	.4375	.562	.437	1.812	1.125	.750	.625	.812	1.062	7/16 20	14	4,218	.20
	MW-8	MG-8	.5000	.625	.500	2.125	1.312	.875	.750	.937	1.187	1/2 20	12	6,660	.33
	MW-10	MG-10	.6250	.750	.562	2.500	1.500	1.000	.875	1.125	1.500	5/8 18	16	7,364	.48
	MW-12	MG-12	.7500	.875	.687	2.875	1.750	1.125	1.000	1.312	1.750	3/4 16	14	11,518	.72
*	MW-14	MG-14	.8750	.875	.765	3.375	2.000	1.300	1.125	1.375	1.875	7/8 14	7	18,476	1.03
*	MW-14-1	MG-14-1	.8750	.875	.687	3.500	2.000	1.312	1.187	1.312	1.812	7/8 14	12	22,843	1.03
3	MW-16	MG-16	1.0000	1.375	1.000	4.125	2.750	1.625	1.500	1.875	2.125	1 1/4 12	17	40,889	2.13
3	MW-16-1	MG-16-1	1.0000	1.375	1.000	4.125	2.750	1.625	1.500	1.875	2.125	1 1/4 ₂	17	43,541	2.41
3	MW-16-2	MG-16-2	1.0000	1.375	1.000	4.125	2.750	1.625	1.500	1.875	2.125	1 12	17	43,541	2.41

ROD END NO.		DIMENSIONS IN MILLIMETERS										a° Misalign. Angle	Ultimate Radial Static Load Capacity Newtons	Approx. Brg. Wt. Grams	
Right Hand	Left Hand†	B + .038 - .013	W + .00 - .13	H ± .13	A ± .38	D ± 25	K ± .25	J ± 25	Ball Dia. Ref.	C + 1.57 - .79	Thread UNF-2B				
**	MW-2	MG-2	3.175	6.35	4.75	20.62	12.70	7.92	6.35	7.92	11.10	6 32 ₁	16	5,344	9
	MW-3	MG-3	4.826	7.92	6.35	26.97	15.88	10.31	7.92	11.10	14.27	10 32	13	6,805	17
	MW-4	MG-4	6.350	9.53	7.14	33.32	19.05	11.91	9.53	12.70	19.05	1/4 28	16	11,297	27
	MW-5	MG-5	7.938	11.10	8.74	34.93	22.23	12.70	11.10	15.88	19.05	5/16 24	14	13,934	42
	MW-6	MG-6	9.525	12.70	10.31	41.28	25.40	17.45	14.27	18.26	23.80	3/8 24	12	17,416	69
	MW-7	MG-7	11.113	14.27	11.10	46.02	28.58	19.05	15.88	20.62	26.97	7/16 20	14	18,759	90
	MW-8	MG-8	12.700	15.88	12.70	53.98	33.32	22.23	19.05	23.80	30.15	1/2 20	12	29,624	149
	MW-10	MG-10	15.875	19.05	14.27	63.50	38.10	25.40	22.23	28.58	38.10	5/8 18	16	32,752	216
	MW-12	MG-12	19.050	22.23	17.45	73.03	44.45	28.58	25.40	33.32	44.45	3/4 16	14	51,237	328
*	MW-14	MG-14	22.225	22.23	19.43	85.73	50.80	33.02	28.58	34.93	47.63	7/8 14	7	82,185	467
*	MW-14-1	MG-14-1	22.225	22.23	17.45	88.90	50.80	33.32	30.15	33.32	46.02	7/8 14	12	101,601	467
4	MW-16	MG-16	25.400	34.93	25.40	104.78	69.85	41.28	38.10	47.63	53.98	1 1/4 12	17	193,670	964
4	MW-16-1	MG-16-1	25.400	34.93	25.40	104.78	69.85	41.28	38.10	47.63	53.98	1 1/4 ₂	17	193,670	1,093
4	MW-16-2	MG-16-2	25.400	34.93	25.40	104.78	69.85	41.28	38.10	47.63	53.98	1 12	17	193,670	1,093



KM & KB SERIES MALE ROD ENDS

General Purpose - Precision - Wear Resistant

Body - Carbon steel protective coated for corrosion resistance. No. 16 series standard body is alloy steel not heat treated.

Race - Alloy steel, heat treated, protective coated for corrosion resistance.

Ball - Alloy steel, heat treated, hard chrome plated.

Notes - All sizes available with studs upon request.

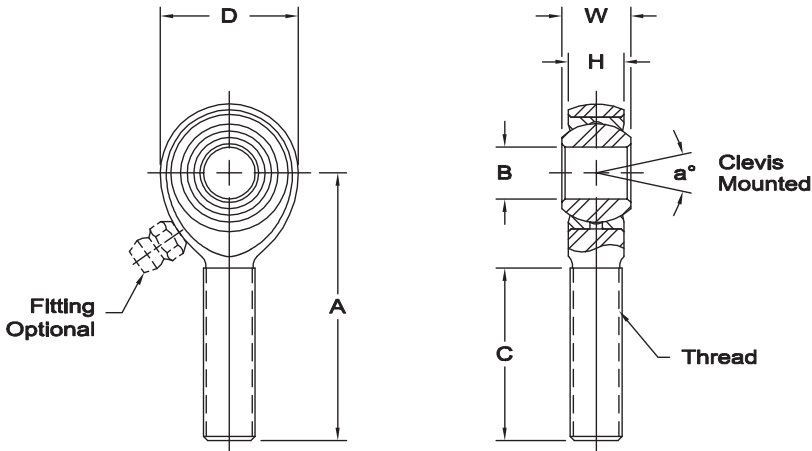

1 Tolerance variation: "D" ± .020, "A" ± .020, "B" + .0035, -.0005, "H" ± .010

2 Tolerance variation: "D" ± .51, "A" ± .51, "B" + .089, .013, "H" ± .25

3 Threads 1 14 UNS.

Units are supplied without grease fittings. When a grease fitting is required, specify by adding suffix as designated.

Z Zerk type fitting

Ex: KM 6Z

F Flush type fitting

Ex: KM 6F

Load ratings apply only to rod ends without grease fittings. For load ratings with fittings, please consult our engineering department.

ROD END NO.		DIMENSIONS IN INCHES								a° Misalign. Angle	Ultimate Radial Static Load Capacity Lbs.	Approx. Brg. Wt. Lbs.
Right Hand	Left Hand	B + .0015 - .0005	W + .000 - .005	H ± .005	A ± .015	D ± .010	Ball Dia. Ref.	C + .062 - .031	Thread UNF-3A			
KM-3	KB-3	.1900	.312	.250	1.250	.625	.437	.750	10 32	13	1,169	.03
KM-4	KB-4	.2500	.375	.281	1.562	.750	.500	1.000	1/4 28	16	2,158	.04
KM-5	KB-5	.3125	.437	.344	1.875	.875	.625	1.250	5/16 24	14	2,784	.07
KM-6	KB-6	.3750	.500	.406	1.938	1.000	.719	1.250	3/8 24	12	3,915	.11
KM-7	KB-7	.4375	.562	.437	2.125	1.125	.812	1.375	7/16 20	14	4,218	.16
KM-8	KB-8	.5000	.625	.500	2.438	1.312	.937	1.500	1/2 20	12	6,660	.25
KM-10	KB-10	.6250	.750	.562	2.625	1.500	1.125	1.625	5/8 18	16	7,364	.38
KM-12	KB-12	.7500	.875	.687	2.875	1.750	1.312	1.750	3/4 16	14	11,518	.60
* KM-14	KB-14	.8750	.875	.765	3.375	2.000	1.375	2.000	7/8 14	7	18,476	.91
1 KM-16	KB-16	1.0000	1.375	1.000	4.125	2.750	1.875	2.125	1 1/4 12	17	43,541	2.41
1 KM-16-1	KB-16-1	1.0000	1.375	1.000	4.125	2.750	1.875	2.125	1 1/4 ₃	17	43,541	2.13
1 KM-16-2	KB-16-2	1.0000	1.375	1.000	4.125	2.750	1.875	2.125	1 12	17	43,541	2.13

ROD END NO.		DIMENSIONS IN MILLIMETERS								a° Misalign. Angle	Ultimate Radial Static Load Capacity Newtons	Approx. Brg. Wt. Grams
Right Hand	Left Hand	B + .038 - .013	W + .00 - .13	H ± .13	A ± .38	D ± .25	Ball Dia. Ref.	C + 1.57 - .79	Thread UNF-3A			
KM-3	KB-3	4.826	7.92	6.35	31.75	15.88	11.10	19.05	10 32	13	5,197	13
KM-4	KB-4	6.350	9.53	7.14	39.67	19.05	12.70	25.40	1/4 28	16	9,600	20
KM-5	KB-5	7.938	11.10	8.74	47.63	22.23	15.88	31.75	5/16 24	14	12,385	33
KM-6	KB-6	9.525	12.70	10.31	49.23	25.40	18.26	31.75	3/8 24	12	17,416	51
KM-7	KB-7	11.113	14.27	11.10	53.98	28.58	20.62	34.93	7/16 20	14	18,759	73
KM-8	KB-8	12.700	15.88	12.70	61.93	33.32	23.80	38.10	1/2 20	12	29,624	113
KM-10	KB-10	15.875	19.05	14.27	66.68	38.10	28.58	41.28	5/8 18	16	32,752	173
KM-12	KB-12	19.050	22.23	17.45	73.03	44.45	33.32	44.45	3/4 16	14	51,237	273
* KM-14	KB-14	22.225	22.23	19.43	85.73	50.80	34.93	50.80	7/8 14	7	82,185	411
2 KM-16	KB-16	25.400	34.93	25.40	104.78	69.85	47.63	53.98	1 1/4 12	17	193,670	1,091
2 KM-16-1	KB-16-1	25.400	34.93	25.40	104.78	69.85	47.63	53.98	1 1/4 ₃	17	193,670	965
2 KM-16-2	KB-16-2	25.400	34.93	25.40	104.78	69.85	47.63	53.98	1 12	17	193,670	965

KW & KG SERIES FEMALE ROD ENDS

General Purpose - Precision - Wear Resistant



Body - Carbon steel protective coated for corrosion resistance. No. 16 series standard body is alloy steel not heat treated.

Race - Alloy steel, heat treated, protective coated for corrosion resistance.

Ball - Alloy steel, heat treated, hard chrome plated.

Notes - All sizes available with studs upon request.

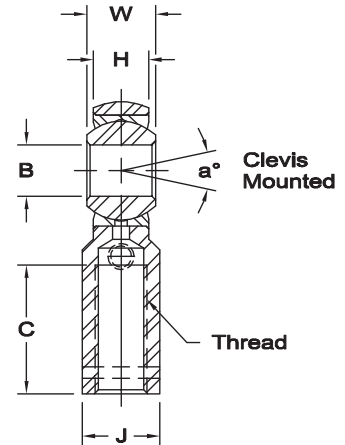
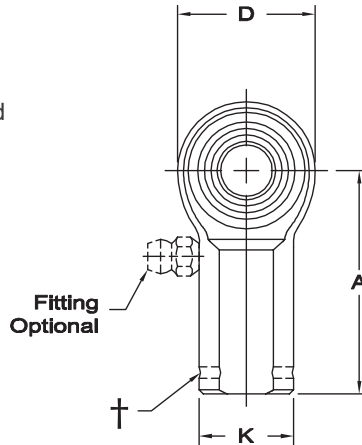

† Left hand units have identification groove near end of shank.

1 Tolerance variation: "D" ± .020, "A" ± .020 "B" + .0035, .0005, "H" ± .010, "K" ± .015, "J" ± .015

2 Tolerance variation: "D" ± .51, "A" ± .51 "B" + .089, .013, "H" ± .25, "K" ± .38, "J" ± .38

3 Threads 1 14 UNS

Units are supplied without grease fittings. When a grease fitting is required, specify by adding suffix as designated.

Z Zerk type fitting

Ex: KW 6Z

F Flush type fitting

Ex: KW 6F

ROD END NO.		DIMENSIONS IN INCHES										a° Misalign. Angle	Ultimate Radial Static Load Capacity Lbs.	Approx. Brg. Wt. Lbs.	
Right Hand	Left Hand†	B + .0015 - .0005	W + .000 - .005	H ± .005	A ± .015	D ± .010	K ± .010	J ± .010	Ball Dia. Ref.	C + .062 - .031	Thread UNF-2B				
	KW-3	KG-3	.1900	.312	.250	1.062	.625	.406	.312	.437	.562	10 32	13	1,531	.04
	KW-4	KG-4	.2500	.375	.281	1.312	.750	.469	.375	.500	.750	1/4 28	16	2,539	.06
	KW-5	KG-5	.3125	.437	.344	1.375	.875	.500	.437	.625	.750	5/16 24	14	3,133	.09
	KW-6	KG-6	.3750	.500	.406	1.625	1.000	.687	.562	.719	.937	3/8 24	12	3,915	.15
	KW-7	KG-7	.4375	.562	.437	1.812	1.125	.750	.625	.812	1.062	7/16 20	14	4,218	.20
	KW-8	KG-8	.5000	.625	.500	2.125	1.312	.875	.750	.937	1.187	1/2 20	12	6,660	.33
	KW-10	KG-10	.6250	.750	.562	2.500	1.500	1.000	.875	1.125	1.500	5/8 18	16	7,364	.48
	KW-12	KG-12	.7500	.875	.687	2.875	1.750	1.125	1.000	1.312	1.750	3/4 16	14	11,518	.72
*	KW-14	KG-14	.8750	.875	.765	3.375	2.000	1.300	1.125	1.375	1.875	7/8 14	7	18,476	1.03
1	KW-16	KG-16	1.0000	1.375	1.000	4.125	2.750	1.625	1.500	1.875	2.125	1 1/4 12	17	40,889	2.13
1	KW-16-1	KG-16-1	1.0000	1.375	1.000	4.125	2.750	1.625	1.500	1.875	2.125	1 14 ₃	17	43,541	2.41
1	KW-16-2	KG-16-2	1.0000	1.375	1.000	4.125	2.750	1.625	1.500	1.875	2.125	1 12	17	43,541	2.41

ROD END NO.		DIMENSIONS IN MILLIMETERS										a° Misalign. Angle	Ultimate Radial Static Load Capacity Newtons	Approx. Brg. Wt. Grams	
Right Hand	Left Hand†	B + .038 - .013	W + .00 - .13	H ± .13	A ± .38	D ± 25	K ± .25	J ± 25	Ball Dia. Ref.	C + 1.57 - .79	Thread UNF-2B				
	KW-3	KG-3	4.826	7.92	6.35	26.97	15.88	10.31	7.92	11.10	14.27	10 32	13	6,805	17
	KW-4	KG-4	6.350	9.53	7.14	33.32	19.05	11.91	9.53	12.70	19.05	1/4 28	16	11,297	27
	KW-5	KG-5	7.938	11.10	8.74	34.93	22.23	12.70	11.10	15.88	19.05	5/16 24	14	13,934	42
	KW-6	KG-6	9.525	12.70	10.31	41.28	25.40	17.45	14.27	18.26	23.80	3/8 24	12	17,416	69
	KW-7	KG-7	11.113	14.27	11.10	46.02	28.58	19.05	15.88	20.62	26.97	7/16 20	14	18,759	90
	KW-8	KG-8	12.700	15.88	12.70	53.98	33.32	22.23	19.05	23.80	30.15	1/2 20	12	29,624	149
	KW-10	KG-10	15.875	19.05	14.27	63.50	38.10	25.40	22.23	28.58	38.10	5/8 18	16	32,752	216
	KW-12	KG-12	19.050	22.23	17.45	73.03	44.45	28.58	25.40	33.32	44.45	3/4 16	14	51,237	328
*	KW-14	KG-14	22.225	22.23	19.43	85.73	50.80	33.02	28.58	34.93	47.63	7/8 14	7	82,185	467
2	KW-16	KG-16	25.400	34.93	25.40	104.78	69.85	41.28	38.10	47.63	53.98	1 1/4 12	17	181,874	964
2	KW-16-1	KG-16-1	25.400	34.93	25.40	104.78	69.85	41.28	38.10	47.63	53.98	1 14 ₃	17	193,670	1,093
2	KW-16-2	KG-16-2	25.400	34.93	25.40	104.78	69.85	41.28	38.10	47.63	53.98	1 12	17	193,670	1,093



LARGE BORE SERIES MALE ROD ENDS

General Purpose & High Strength – Precision – Wear Resistant (PTFE Liners Available)

ROD ENDS

1 1/4", 1 1/2" & 2" SIZES

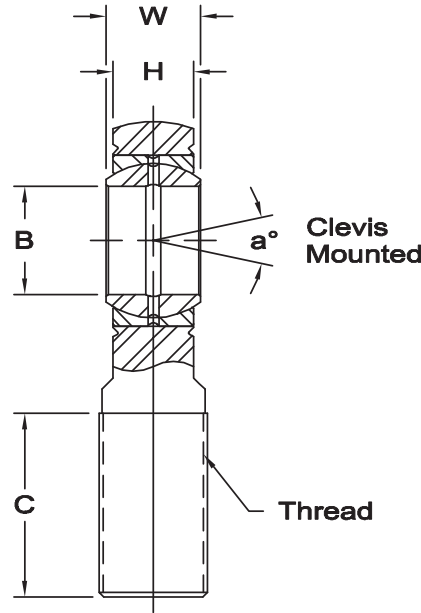
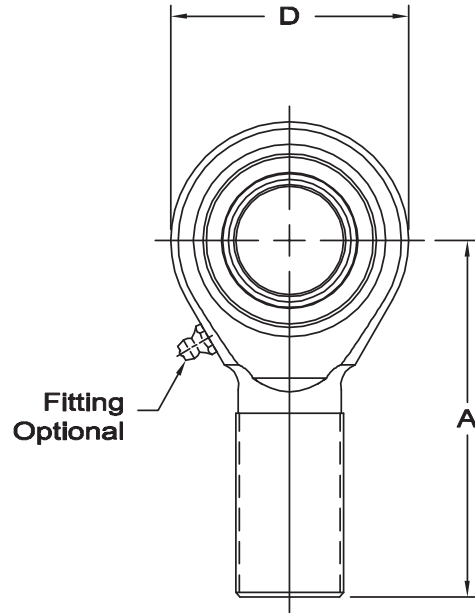

Body (K-Series) - Alloy steel, protective coated for corrosion resistance.

Body (A-Series) - Alloy steel, heat treated, protective coated for corrosion resistance.

Race - 52100 steel, heat treated, protective coated for corrosion resistance.

Ball - 52100 steel, heat treated, protective coated for corrosion resistance.

1 Tolerance variation: "H" ± .005
2 Threads 2 12 UN 3A

Units are supplied without grease fittings. When a grease fitting is required, specify by adding suffix as designated.

Z Zerk type fitting Ex: KM 24Z 1
F Flush type fitting Ex: KM 24F 1
T PTFE liner Ex: KM 24T 1

K-SERIES – BODY NON HEAT-TREATED

ROD END NO.		DIMENSIONS IN INCHES								a° Misalign. Angle	Ultimate Radial Static Load Capacity Lbs.	Approx. Brg. Wt. Lbs.	
Right Hand	Left Hand	B + .0000 - .0005	W + .000 - .005	H ± .020	A ± .040	D ± .030	Ball Dia. Ref.	C + .062 - .031	Thread UNF-3A				
1	KM-20-1	KB-20-1	1.2500	1.093	.937	4.125	2.750	1.795	2.125	1 1/4 12	7.0	44,500	2.41
	KM-24-1	KB-24-1	1.5000	1.312	1.125	5.375	3.500	2.155	3.000	1 1/2 12	6.5	64,770	4.75
	KM-32-1	KB-32-1	2.0000	1.750	1.500	8.000	5.000	2.875	4.500	2 1/2	6.0	153,528	14.25

A-SERIES/XAM-SERIES – BODY HEAT-TREATED

ROD END NO.		DIMENSIONS IN INCHES								a° Misalign. Angle	Ultimate Radial Static Load Capacity Lbs.	Approx. Brg. Wt. Lbs.	
Right Hand	Left Hand	B + .0000 - .0005	W + .000 - .005	H ± .020	A ± .040	D ± .030	Ball Dia. Ref.	C + .062 - .031	Thread UNF-3A				
1	AM-20-1	AB-20-1	1.2500	1.093	.937	4.125	2.750	1.795	2.125	1 1/4 12	7.0	79,728	2.41
	XAM-20-1	XAB-20-1	1.2500	1.093	.937	4.125	2.750	1.795	2.250	1 1/2 12	7.0	79,728	2.63
	AM-24-1	AB-24-1	1.5000	1.312	1.125	5.375	3.500	2.155	3.000	1 1/2 12	6.5	126,450	4.74
	XAM-24-1	XAB-24-1	1.5000	1.312	1.125	5.375	3.500	2.155	3.000	1 3/4 12	6.5	126,450	6.06
	AM-32-1	AB-32-1	2.0000	1.750	1.500	8.000	5.010	2.875	4.500	2 1/2	6.0	225,924	14.25

LARGE BORE SERIES FEMALE ROD ENDS

General Purpose & High Strength – Precision – Wear Resistant (PTFE Liners Available)



ROD ENDS 1 1/4", 1 1/2" & 2" SIZES



Body (K-Series) - Alloy steel, protective coated for corrosion resistance.

Body (A-Series) - Alloy steel, heat treated, protective coated for corrosion resistance.

Race - 52100 steel, heat treated, protective coated for corrosion resistance.

Ball - 52100 steel, heat treated, protective coated for corrosion resistance.

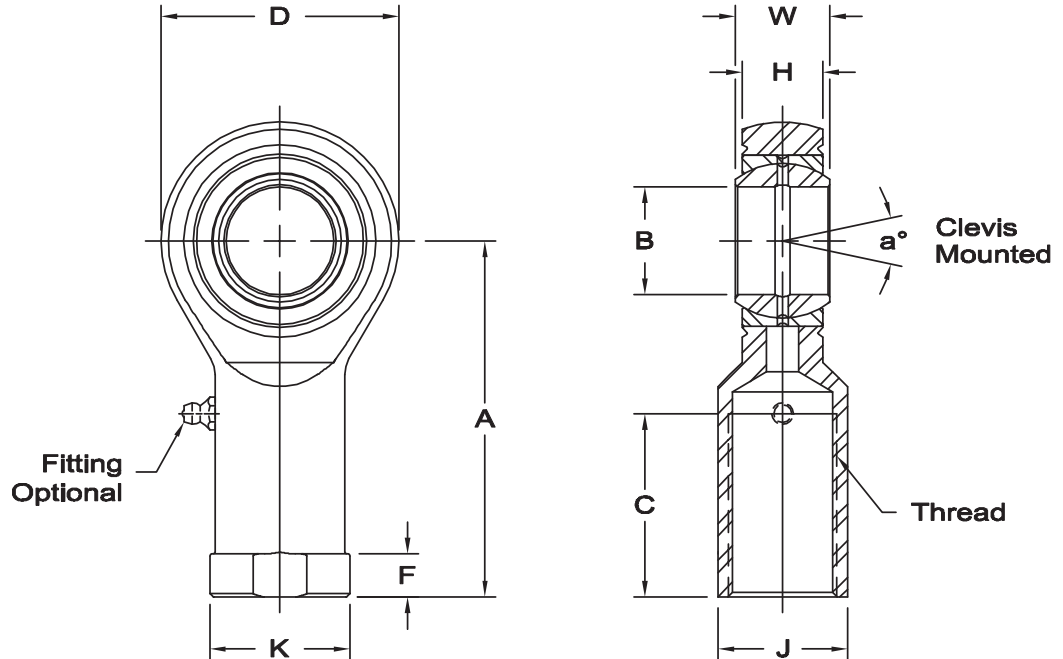

1 Tolerance variation: "H" ± .005, "K" ± .015, "J" ± .015, "F" ± .015
2 Threads 2 12 UN 2B

Units are supplied without grease fittings. When a grease fitting is required, specify by adding suffix as designated.

Z Zerk type fitting Ex: KW 24Z 1
F Flush type fitting Ex: KW 24F 1
T PTFE liner Ex: KW 24T 1

K-SERIES – BODY NON HEAT-TREATED

ROD END NO.		DIMENSIONS IN INCHES											a° Misalign. Angle	Ultimate Radial Static Load Capacity Lbs.	Approx. Brg. Wt. Lbs.
Right Hand	Left Hand	B +.0000 -.0005	W +.000 -.005	H ±.020	A ±.040	D ±.030	K ±.045	J ±.030	F ±.030	Ball Dia. Ref.	C +.062 -.031	Thread UNF-2B			
1	KW-20-1 KG-20-1	1.2500	1.093	.937	4.125	2.750	1.625	1.500	.500	1.795	2.125	1 1/4 12	7.0	44,500	2.125
	KW-24-1 KG-24-1	1.5000	1.312	1.125	5.375	3.500	2.250	2.000	.875	2.155	2.625	1 1/2 12	6.5	64,770	6.50
	KW-32-1 KG-32-1	2.0000	1.750	1.500	8.000	5.000	3.125	2.750	2.062	2.875	4.000	2 12 ₂	6.0	153,528	15.00

A-SERIES – BODY HEAT-TREATED

ROD END NO.		DIMENSIONS IN INCHES											a° Misalign. Angle	Ultimate Radial Static Load Capacity Lbs.	Approx. Brg. Wt. Lbs.
Right Hand	Left Hand	B +.0000 -.0005	W +.000 -.005	H ±.020	A ±.040	D ±.030	K ±.045	J ±.030	F ±.030	Ball Dia. Ref.	C +.062 -.031	Thread UNF-2B			
1	AW-20-1 AG-20-1	1.2500	1.093	.937	4.125	2.750	1.625	1.500	.500	1.795	2.125	1 1/4 12	7.0	79,728	2.13
	AW-24-1 AG-24-1	1.5000	1.312	1.125	5.375	3.500	2.250	2.000	.875	2.155	2.625	1 1/2 12	6.5	126,450	6.50
	AW-32-1 AG-32-1	2.0000	1.750	1.500	8.000	5.010	3.155	2.750	2.062	2.875	4.000	2 12 ₂	6.0	225,924	15.00



LARGE BORE SERIES MALE ROD ENDS

General Purpose & High Strength – Precision – PTFE Lined

ROD ENDS

1 1/4", 1 1/2" & 2" SIZES

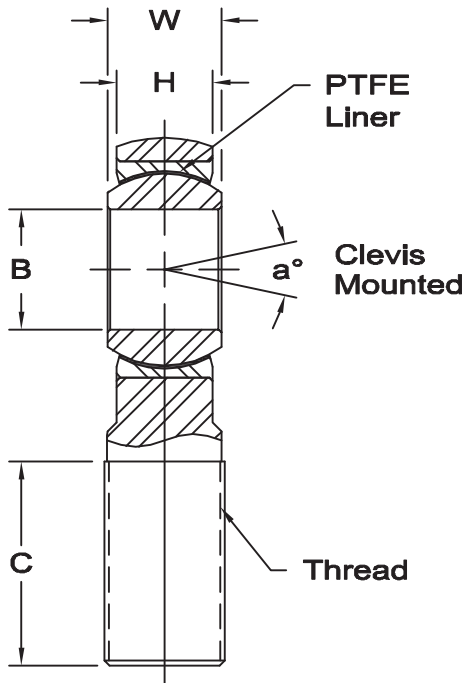
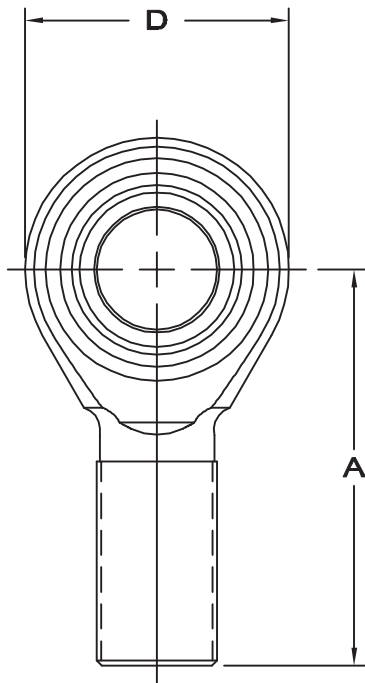

Body (M-Series) - Alloy steel, protective coated for corrosion resistance.

Body (A-Series) - Alloy steel, heat treated, protective coated for corrosion resistance.

Race - Carbon steel, PTFE lined.

Ball - Alloy steel, heat treated, hard chrome plated.

1 Threads 2 12 UN 3A

M-SERIES – BODY NON HEAT-TREATED

ROD END NO.		DIMENSIONS IN INCHES								a° Misalign. Angle	Ultimate Radial Static Load Capacity Lbs.	Approx. Brg. Wt. Lbs.
Right Hand	Left Hand	B + .0015 - .0005	W ± .005	H ± .020	A ± .040	D ± .030	Ball Dia. Ref.	C + .062 - .031	Thread UNF-3A			
MM-20T	MB-20T	1.2500	1.187	1.000	4.125	2.750	2.000	2.125	1 1/4 12	9.0	31,480	2.41
MM-24T	MB-24T	1.5000	1.375	1.125	5.375	3.500	2.312	3.000	1 1/2 12	8.75	66,264	4.75
MM-32T	MB-32T	2.0000	1.750	1.437	8.020	5.010	2.937	4.500	2 1/2 12	7.5	163,634	14.25

A-SERIES – BODY HEAT-TREATED

ROD END NO.		DIMENSIONS IN INCHES								a° Misalign. Angle	Ultimate Radial Static Load Capacity Lbs.	Approx. Brg. Wt. Lbs.
Right Hand	Left Hand	B + .0015 - .0005	W ± .005	H ± .020	A ± .040	D ± .030	Ball Dia. Ref.	C + .062 - .031	Thread UNF-3A			
AM-20T	AB-20T	1.2500	1.187	1.000	4.125	2.750	2.000	2.125	1 1/4 12	9.0	65,047	2.41
AM-24T	AB-24T	1.5000	1.375	1.125	5.375	3.500	2.312	3.000	1 1/2 12	8.75	115,610	4.75
AM-32T	AB-32T	2.0000	1.750	1.437	8.020	5.010	2.937	4.500	2 1/2 12	7.5	280,740	14.25

LARGE BORE SERIES FEMALE ROD ENDS

General Purpose & High Strength – Precision – PTFE Lined



ROD ENDS 1 1/4", 1 1/2" & 2" SIZES



Body (M-Series) - Alloy steel, protective coated for corrosion resistance.

Body (A-Series) - Alloy steel, heat treated, protective coated for corrosion resistance.

Race - Carbon steel, PTFE lined.

Ball - Alloy steel, heat treated, hard chrome plated.

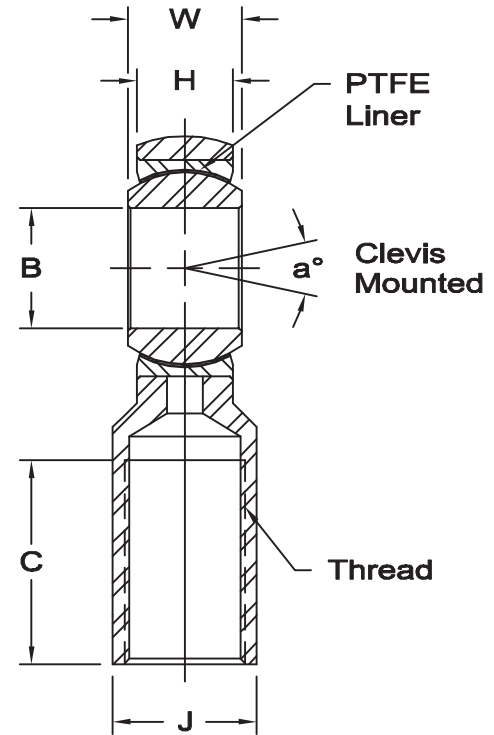
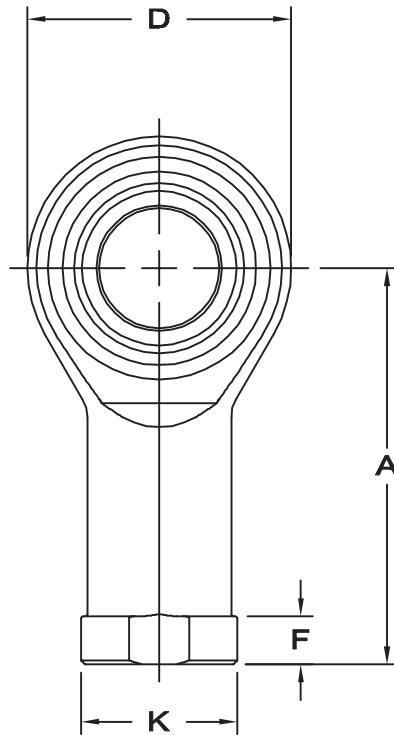

1Threads 2 12 UN 2B

M-SERIES – BODY NON HEAT-TREATED

ROD END NO.		DIMENSIONS IN INCHES											a° Misalign. Angle	Ultimate Radial Static Load Capacity Lbs.	Approx. Brg. Wt. Lbs.
Right Hand	Left Hand	B +.0015 -.0005	W ±.005	H ±.020	A ±.040	D ±.030	K ±.045	J ±.030	F ±.030	Ball Dia. Ref.	C +.062 -.031	Thread UNF-2B			
MW-20T	MG-20T	1.2500	1.187	1.000	4.125	2.750	1.625	1.500	.500	2.000	2.125	1 1/4 12	9.0	31,480	2.13
MW-24T	MG-24T	1.5000	1.375	1.125	5.375	3.500	2.250	2.000	.875	2.312	2.625	1 1/2 12	8.75	66,264	6.50
MW-32T	MG-32T	2.0000	1.750	1.437	8.020	5.010	3.155	2.750	2.062	2.937	4.000	2 12,	7.5	163,634	15.00

A-SERIES – BODY HEAT-TREATED

ROD END NO.		DIMENSIONS IN INCHES											a° Misalign. Angle	Ultimate Radial Static Load Capacity Lbs.	Approx. Brg. Wt. Lbs.
Right Hand	Left Hand	B +.0015 -.0005	W ±.005	H ±.020	A ±.040	D ±.030	K ±.045	J ±.030	F ±.030	Ball Dia. Ref.	C +.062 -.031	Thread UNF-2B			
AW-20T	AG-20T	1.2500	1.187	1.000	4.125	2.750	1.625	1.500	.500	2.000	2.125	1 1/4 12	9.0	65,047	2.13
AW-24T	AG-24T	1.5000	1.375	1.125	5.375	3.500	2.250	2.000	.875	2.312	2.625	1 1/2 12	8.75	115,610	6.50
AW-32T	AG-32T	2.0000	1.750	1.437	8.020	5.010	3.155	2.750	2.062	2.937	4.000	2 12,	7.5	280,740	15.00



CAM & CAB SERIES MALE ROD ENDS

High Strength – Economy Series

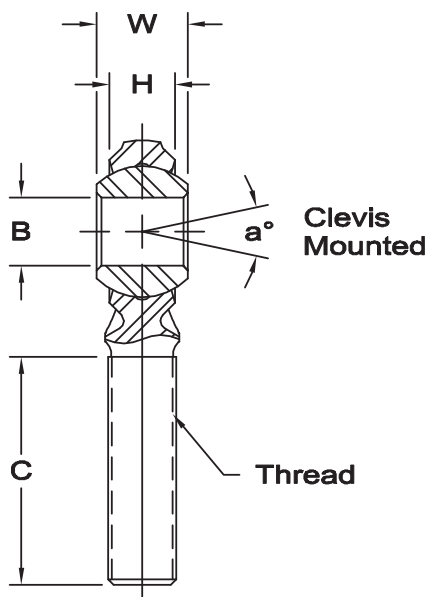
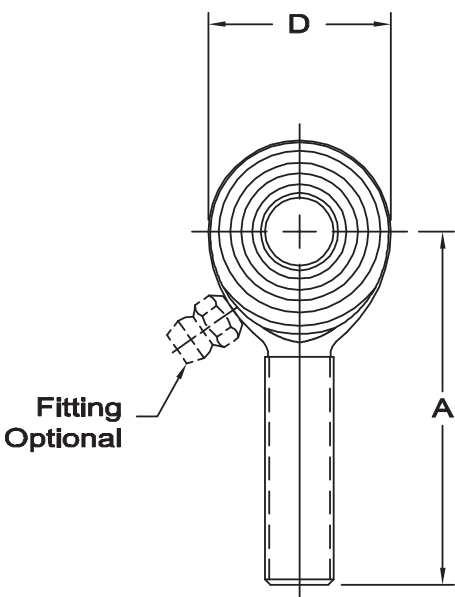

Body - Alloy steel, heat treated, protective coated for corrosion resistance.

Ball - Alloy steel, heat treated, hard chrome plated.

Units are supplied without grease fittings. When a grease fitting is required, specify by adding suffix as designated.

Z Zerk type fitting

Ex: CAM 6Z

F Flush type fitting

Ex: CAM 6F

Load ratings apply only to rod ends without grease fittings.

For load ratings with fittings, please consult our engineering department.

*Grease fitting not available on this size.

ROD END NO.		DIMENSIONS IN INCHES								a° Misalign. Angle	Ultimate Radial Static Load Capacity Lbs.	Approx. Brg. Wt. Lbs.
Right Hand	Left Hand	B + .0025 - .0005	W + .005	H Ref.	A ± .015	D Ref.	Ball Dia. Ref.	C + .062 - .031	Thread UNF-3A			
* CAM-5	CAB-5	.3125	.437	.312	1.875	.875	.625	1.250	5/16 24	22	6,684	.07
CAM-6	CAB-6	.3750	.500	.359	1.938	1.000	.719	1.250	3/8 24	22	9,088	.11
CAM-7	CAB-7	.4375	.562	.406	2.125	1.125	.812	1.375	7/16 20	21	11,445	.15
CAM-8	CAB-8	.5000	.625	.453	2.438	1.312	.937	1.500	1/2 20	20	15,479	.24
CAM-10	CAB-10	.6250	.750	.484	2.625	1.500	1.125	1.625	5/8 18	26	17,470	.36
CAM-12	CAB-12	.7500	.875	.593	2.875	1.750	1.312	1.750	3/4 16	24	24,471	.57

ROD END NO.		DIMENSIONS IN MILLIMETERS								a° Misalign. Angle	Ultimate Radial Static Load Capacity Newtons	Approx. Brg. Wt. Grams
Right Hand	Left Hand	B + .064 - .013	W + .13	H Ref.	A + .38	D Ref.	Ball Dia. Ref.	C + 1.57 - .79	Thread UNF-3A			
* CAM-5	CAB-5	7.938	11.10	7.92	47.63	22.23	15.88	31.75	5/16 24	22	30,531	32
CAM-6	CAB-6	9.525	12.70	9.12	49.23	25.40	18.26	31.75	3/8 24	22	40,423	50
CAM-7	CAB-7	11.113	14.27	10.31	53.98	28.58	20.62	34.93	7/16 20	21	50,907	68
CAM-8	CAB-8	12.700	15.88	11.50	61.93	33.32	23.80	38.10	1/2 20	20	68,851	109
CAM-10	CAB-10	15.875	19.05	12.29	66.68	38.10	28.58	41.28	5/8 18	26	77,707	163
CAM-12	CAB-12	19.050	22.23	15.06	73.03	44.45	33.32	44.45	3/4 16	24	108,847	259

VCAM & VCAB SERIES MALE ROD ENDS

High Strength – Self Lubricating – Economy Series



Body - Alloy steel, heat treated, protective coated for corrosion resistance.

Ball - Alloy steel, heat treated, hard chrome plated.

Bushing - Steel Backed, PTFE Composite

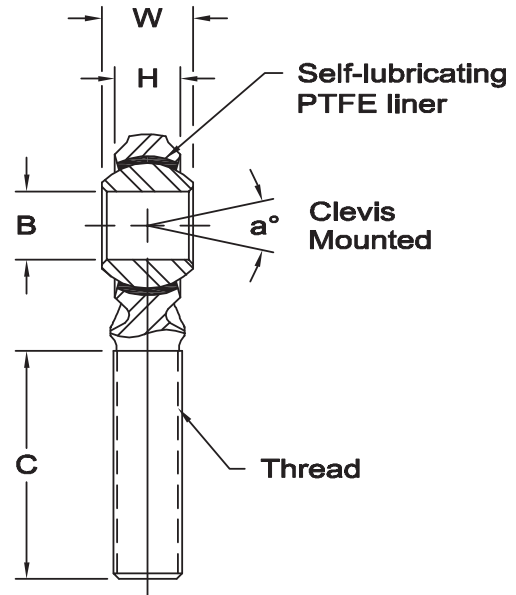
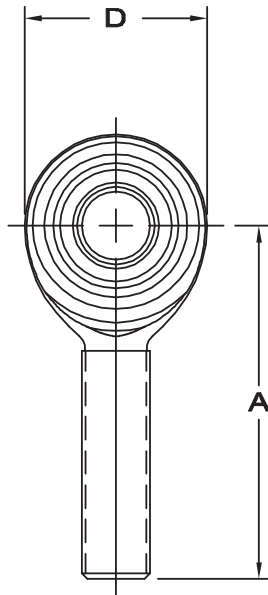

ROD END NO.		DIMENSIONS IN INCHES								a° Misalign. Angle	Ultimate Radial Static Load Capacity Lbs.	Approx. Brg. Wt. Lbs.
Right Hand	Left Hand	B + .0025 - .0005	W + .005	H Ref.	A ± .015	D Ref.	Ball Dia. Ref.	C + .062 - .031	Thread UNF-3A			
VCAM-5	VCAB-5	.3125	.437	.312	1.875	.875	.593	1.250	5/16 24	18	5,032	.07
VCAM-6	VCAB-6	.3750	.500	.359	1.938	1.000	.687	1.250	3/8 24	18	6,533	.11
VCAM-7	VCAB-7	.4375	.562	.406	2.125	1.125	.781	1.375	7/16 20	17	8,054	.15
VCAM-8	VCAB-8	.5000	.625	.453	2.438	1.312	.875	1.500	1/2 20	16	13,425	.24
VCAM-10	VCAB-10	.6250	.750	.484	2.625	1.500	1.062	1.625	5/8 18	22	14,755	.36
VCAM-12	VCAB-12	.7500	.875	.593	2.875	1.750	1.250	1.750	3/4 16	20	21,150	.57

ROD END NO.		DIMENSIONS IN MILLIMETERS								a° Misalign. Angle	Ultimate Radial Static Load Capacity Newtons	Approx. Brg. Wt. Grams
Right Hand	Left Hand	B + .064 - .013	W + .13	H Ref.	A + .38	D Ref.	Ball Dia. Ref.	C + 1.57 - .79	Thread UNF-3A			
VCAM-5	VCAB-5	7.938	11.10	7.92	47.63	22.23	15.06	31.75	5/16 24	18	22,382	32
VCAM-6	VCAB-6	9.525	12.70	9.12	49.23	25.40	17.45	31.75	3/8 24	18	29,059	50
VCAM-7	VCAB-7	11.113	14.27	10.31	53.98	28.58	19.84	34.93	7/16 20	17	35,824	68
VCAM-8	VCAB-8	12.700	15.88	11.50	61.93	33.32	22.23	38.10	1/2 20	16	59,714	109
VCAM-10	VCAB-10	15.875	19.05	12.29	66.68	38.10	26.97	41.28	5/8 18	22	65,630	163
VCAM-12	VCAB-12	19.050	22.23	15.06	73.03	44.45	31.75	44.45	3/4 16	20	94,075	259



AM & AB SERIES MALE ROD ENDS

High Strength Alloy – Precision (PTFE Liners Available)

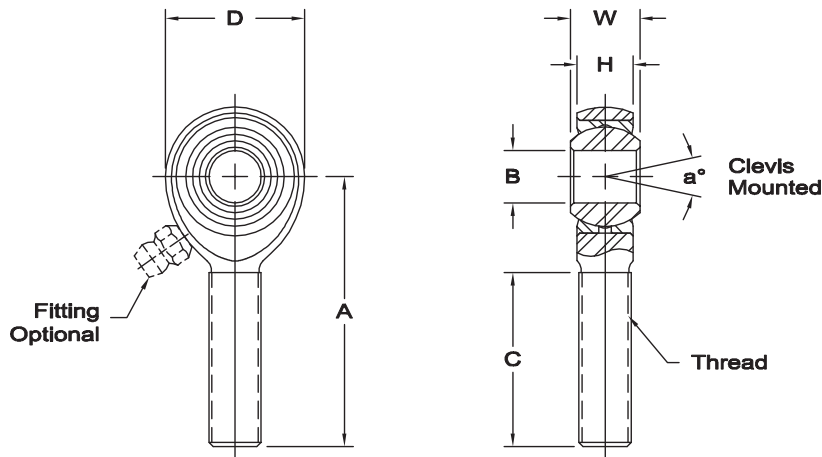

Body - Alloy steel, heat treated, protective coated for corrosion resistance.

Race - Alloy steel, heat treated, protective coated for corrosion resistance (Carbon steel with PTFE Liners).

Ball - Alloy steel, heat treated, hard chrome plated.



- 1 Tolerance variation: "D" ± .020, "A" ± .020, "B" + .0035, .0005, "H" ± .010
- 2 Tolerance variation: "D" ± .51, "A" ± .51, "B" + .089, .013, "H" + .25
- 3 Threads 1 14 UNS.

Units are supplied without grease fittings. When a grease fitting is required, specify by adding suffix as designated.

- Z Zerk type fitting Ex: AM 6Z
- F Flush type fitting Ex: AM 6F
- T PTFE liner Ex: AM 6T

Load ratings apply only to rod ends without grease fittings. For load ratings with fittings, please consult our engineering department.

ROD END NO.		DIMENSIONS IN INCHES								a° Misalign. Angle	Ultimate Radial Static Load Capacity Lbs.	Approx. Brg. Wt. Lbs.
Right Hand	Left Hand	B + .0015 - .0005	W + .000 - .005	H ± .005	A ± .010	D ± .010	Ball Dia. Ref.	C + .062 - .031	Thread UNF-3A			
AM-3	AB-3	.1900	.312	.250	1.250	.625	.437	.750	10 32	13	2,851	.03
AM-4	AB-4	.2500	.375	.281	1.562	.750	.500	1.000	1/4 28	16	5,260	.04
AM-5	AB-5	.3125	.437	.344	1.875	.875	.625	1.250	5/16 24	14	7,639	.07
AM-6	AB-6	.3750	.500	.406	1.938	1.000	.719	1.250	3/8 24	12	9,544	.11
AM-7	AB-7	.4375	.562	.437	2.125	1.125	.812	1.375	7/16 20	14	10,285	.16
AM-8	AB-8	.5000	.625	.500	2.438	1.312	.937	1.500	1/2 20	12	16,238	.25
AM-10	AB-10	.6250	.750	.562	2.625	1.500	1.125	1.625	5/8 18	16	17,955	.38
AM-12	AB-12	.7500	.875	.687	2.875	1.750	1.312	1.750	3/4 16	14	28,081	.60
AM-12-20	AB-12-20	.7500	.875	.687	2.875	1.750	1.312	1.750	7/8 14	14	28,081	.72
AM-14	AB-14	.8750	.875	.765	3.375	2.000	1.375	2.000	7/8 14	7	45,051	.91
* AM-14-1	AB-14-1	.8750	.875	.687	3.375	2.000	1.312	1.875	7/8 14	12	55,692	.91
1 AM-16	AB-16	1.0000	1.375	1.000	4.125	2.750	1.875	2.125	1 1/4 12	17	76,200	2.41
1 AM-16-1	AB-16-1	1.0000	1.375	1.000	4.125	2.750	1.875	2.125	1 1/4 ₃	17	76,200	2.13
1 AM-16-2	AB-16-2	1.0000	1.375	1.000	4.125	2.750	1.875	2.125	1 12	17	76,200	2.13

ROD END NO.		DIMENSIONS IN MILLIMETERS								a° Misalign. Angle	Ultimate Radial Static Load Capacity Newtons	Approx. Brg. Wt. Grams
Right Hand	Left Hand	B + .038 - .013	W + .00 - .13	H ± .13	A ± .25	D ± .25	Ball Dia. Ref.	C + 1.57 - .79	Thread UNF-3A			
AM-3	AB-3	4.826	7.92	6.35	31.75	15.88	11.10	19.05	10 32	13	12,679	13
AM-4	AB-4	6.350	9.53	7.14	39.67	19.05	12.70	25.40	1/4 28	16	23,397	20
AM-5	AB-5	7.938	11.10	8.74	47.63	22.23	15.88	31.75	5/16 24	14	33,978	33
AM-6	AB-6	9.525	12.70	10.31	49.23	25.40	18.26	31.75	3/8 24	12	42,450	51
AM-7	AB-7	11.113	14.27	11.10	53.98	28.58	20.62	34.93	7/16 20	14	45,745	73
AM-8	AB-8	12.700	15.88	12.70	61.93	33.32	23.80	38.10	1/2 20	12	72,231	113
AM-10	AB-10	15.875	19.05	14.27	66.68	38.10	28.58	41.28	5/8 18	16	79,861	173
AM-12	AB-12	19.050	22.23	17.45	73.03	44.45	33.32	44.45	3/4 16	14	124,910	273
AM-12-20	AB-12-20	19.050	22.23	17.45	73.03	44.45	33.32	44.45	7/8 14	14	124,910	273
AM-14	AB-14	22.225	22.23	19.43	85.73	50.80	34.93	50.80	7/8 14	7	200,387	411
* AM-14-1	AB-14-1	22.225	22.23	17.45	85.73	50.80	33.32	47.63	7/8 14	12	247,718	411
2 AM-16	AB-16	25.400	34.93	25.40	104.78	69.85	47.63	53.98	1 1/4 12	17	338,937	1,091
2 AM-16-1	AB-16-1	25.400	34.93	25.40	104.78	69.85	47.63	53.98	1 1/4 ₃	17	338,937	965
2 AM-16-2	AB-16-2	25.400	34.93	25.40	104.78	69.85	47.63	53.98	1 12	17	338,937	965

AW & AG SERIES FEMALE ROD ENDS

High Strength Alloy – Precision (PTFE Liners Available)



Body - Alloy steel, heat treated, protective coated for corrosion resistance.

Race - Alloy steel, heat treated, protective coated for corrosion resistance (Carbon steel with PTFE Liners).

Ball - Alloy steel, heat treated, hard chrome plated.

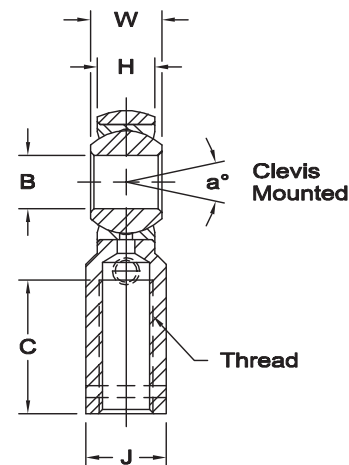
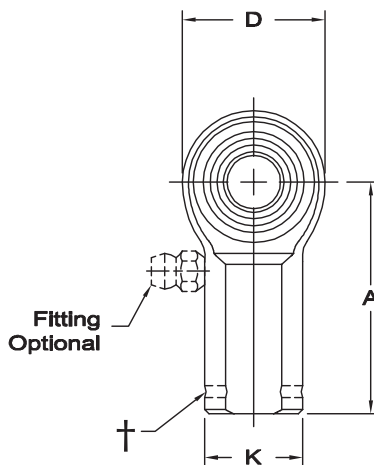

† Left hand units have identification groove near end of shank

1 Tolerance variation: "D" ± .020, "A" + .020 "B" + .0035, .0005, "H" ± .010, "K" ± .015, "J" ± .015

2 Tolerance variation: "D" ± .51, "A" + .51 "B" + .089, .013, "H" ± .25, "K" ± .38, "J" + .38

3 Threads 1 14 UNS

4 Notes 1 and 2 both have UNF 2B threads.

Units are supplied without grease fittings. When a grease fitting is required, specify by adding suffix as designated.

- Z Zerk type fitting Ex: AW 6Z
- F Flush type fitting Ex: AW 6F
- T PTFE liner Ex: AW 6T

ROD END NO.		DIMENSIONS IN INCHES										a° Misalign. Angle	Ultimate Radial Static Load Capacity Lbs.	Approx. Brg. Wt. Lbs.
Right Hand	Left Hand†	B + .0015 - .0005	W + .000 - .005	H ± .005	A ± .010	D ± .010	K ± .010	J ± .010	Ball Dia. Ref.	C + .062 - .031	Thread UNF-3B			
AW-3	AG-3	.1900	.312	.250	1.062	.625	.406	.312	.437	.562	10 32	13	3,733	.04
AW-4	AG-4	.2500	.375	.281	1.312	.750	.469	.375	.500	.750	1/4 28	16	6,190	.06
AW-5	AG-5	.3125	.437	.344	1.375	.875	.500	.437	.625	.750	5/16 24	14	7,639	.09
AW-6	AG-6	.3750	.500	.406	1.625	1.000	.687	.562	.719	.937	3/8 24	12	9,544	.15
AW-7	AG-7	.4375	.562	.437	1.812	1.125	.750	.625	.812	1.062	7/16 20	14	10,285	.20
AW-8	AG-8	.5000	.625	.500	2.125	1.312	.875	.750	.937	1.187	1/2 20	12	16,238	.33
AW-10	AG-10	.6250	.750	.562	2.500	1.500	1.000	.875	1.125	1.500	5/8 18	16	17,955	.48
AW-12	AG-12	.7500	.875	.687	2.875	1.750	1.125	1.000	1.312	1.750	3/4 16	14	28,081	.72
* AW-14	AG-14	.8750	.875	.765	3.375	2.000	1.300	1.125	1.375	1.875	7/8 14	7	45,051	1.03
1 AW-16	AG-16	1.0000	1.375	1.000	4.125	2.750	1.625	1.500	1.875	2.125	1 1/4 12	17	76,200	2.13
1 AW-16-1	AG-16-1	1.0000	1.375	1.000	4.125	2.750	1.625	1.500	1.875	2.125	1 14 ₃	17	76,200	2.41
1 AW-16-2	AG-16-2	1.0000	1.375	1.000	4.125	2.750	1.625	1.500	1.875	2.125	1 12	17	76,200	2.41

ROD END NO.		DIMENSIONS IN MILLIMETERS										a° Misalign. Angle	Ultimate Radial Static Load Capacity Newtons	Approx. Brg. Wt. Grams
Right Hand	Left Hand†	B + .038 - .013	W + .00 - .13	H ± .13	A ± .25	D ± .25	K ± .25	J ± .25	Ball Dia. Ref.	C + 1.57 - .79	Thread UNF-3B			
AW-3	AG-3	4.826	7.92	6.35	26.97	15.88	10.31	7.92	11.10	14.27	10 32	13	16,602	17
AW-4	AG-4	6.350	9.53	7.14	33.32	19.05	11.91	9.53	12.70	19.05	1/4 28	16	27,535	27
AW-5	AG-5	7.938	11.10	8.74	34.93	22.23	12.70	11.10	15.88	19.05	5/16 24	14	33,978	42
AW-6	AG-6	9.525	12.70	10.31	41.28	25.40	17.45	14.27	18.26	23.80	3/8 24	12	42,450	69
AW-7	AG-7	11.113	14.27	11.10	46.02	28.58	19.05	15.88	20.62	26.97	7/16 20	14	45,745	90
AW-8	AG-8	12.700	15.88	12.70	53.98	33.32	22.23	19.05	23.80	30.15	1/2 20	12	72,231	149
AW-10	AG-10	15.875	19.05	14.27	63.50	38.10	25.40	22.23	28.58	38.10	5/8 18	16	79,861	216
AW-12	AG-12	19.050	22.23	17.45	73.03	44.45	28.58	25.40	33.32	44.45	3/4 16	14	124,910	328
* AW-14	AG-14	22.225	22.23	19.43	85.73	50.80	33.02	28.58	34.93	47.63	7/8 14	7	200,387	467
2 AW-16	AG-16	25.400	34.93	25.40	104.78	69.85	41.28	38.10	47.63	53.98	1 1/4 12	17	338,937	964
2 AW-16-1	AG-16-1	25.400	34.93	25.40	104.78	69.85	41.28	38.10	47.63	53.98	1 14 ₃	17	338,937	1,093
2 AW-16-2	AG-16-2	25.400	34.93	25.40	104.78	69.85	41.28	38.10	47.63	53.98	1 12	17	338,937	1,093



CM-ET & CB-ET SERIES STAINLESS STEEL MALE ROD ENDS

Corrosion Resistant – Precision – Self Lubricating

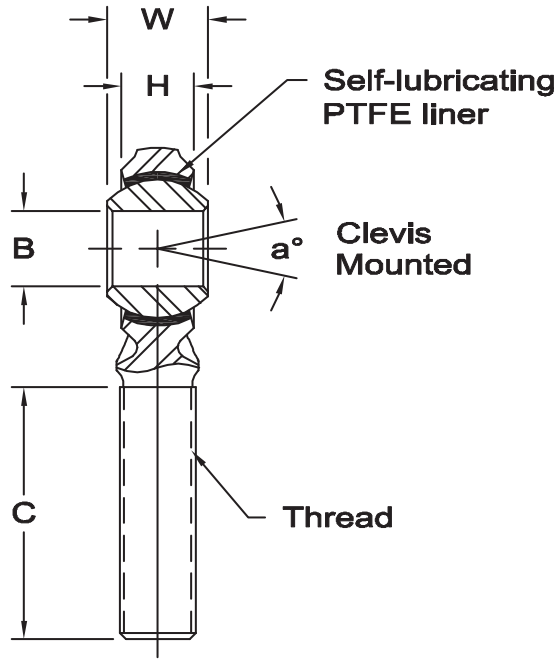
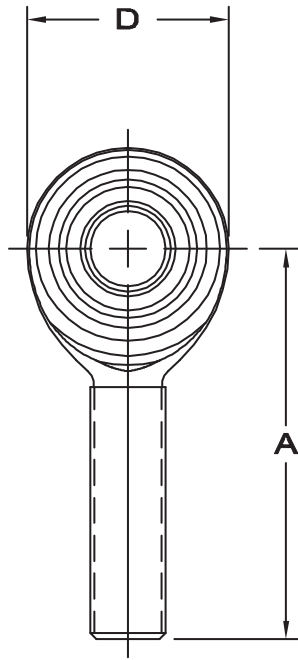

Body - 17-4 PH stainless steel (AMS 5342) heat treated.

Ball - 440 C stainless steel (AMS 5630), heat treated, hard chrome plated.

Bushing - 17-4 PH stainless steel, heat treated, PTFE lined.

(1) Manufacturer's Option: 2A

ROD END NO.		DIMENSIONS IN INCHES								a° Misalign. Angle	Ultimate Radial Static Load Capacity Lbs.	Approx. Brg. Wt. Lbs.
Right Hand	Left Hand	B + .0015 - .0005	W + .000 - .005	H Ref.	A ± .015	D Ref.	Ball Dia. Ref.	C + .062 - .031	Thread UNF-3A (1)			
CM-5ET	CB-5ET	.3125	.437	.312	1.875	.875	.593	1.250	5/16 24	18	6,451	.07
CM-6ET	CB-6ET	.3750	.500	.359	1.938	1.000	.687	1.250	3/8 24	18	8,627	.11
CM-7ET	CB-7ET	.4375	.562	.406	2.125	1.125	.781	1.375	7/16 20	17	9,370	.15
CM-8ET	CB-8ET	.5000	.625	.453	2.438	1.312	.875	1.500	1/2 20	16	15,130	.24
CM-10ET	CB-10ET	.6250	.750	.484	2.625	1.500	1.062	1.625	5/8 18	22	16,922	.36
CM-12ET	CB-12ET	.7500	.875	.593	2.875	1.750	1.250	1.750	3/4 16	20	25,549	.57

ROD END NO.		DIMENSIONS IN MILLIMETERS								a° Misalign. Angle	Ultimate Radial Static Load Capacity Newtons	Approx. Brg. Wt. Grams
Right Hand	Left Hand	B + .038 - .013	W + .00 - .13	H Ref.	A + .38	D Ref.	Ball Dia. Ref.	C + 1.57 - .79	Thread UNF-3A			
CM-5ET	CB-5ET	7.938	11.10	7.92	47.63	22.23	15.06	31.75	5/16 24	18	28,693	32
CM-6ET	CB-6ET	9.525	12.70	9.12	49.23	25.40	17.45	31.75	3/8 24	18	38,371	50
CM-7ET	CB-7ET	11.113	14.27	10.31	53.98	28.58	19.84	34.93	7/16 20	17	41,676	68
CM-8ET	CB-8ET	12.700	15.88	11.50	61.93	33.32	22.23	38.10	1/2 20	16	67,299	109
CM-10ET	CB-10ET	15.875	19.05	12.29	66.68	38.10	26.97	41.28	5/8 18	22	75,271	163
CM-12ET	CB-12ET	19.050	22.23	15.06	73.03	44.45	31.75	44.45	3/4 16	20	113,642	259

CW-ET & CG-ET SERIES STAINLESS STEEL FEMALE ROD ENDS

Corrosion Resistant – Precision – Self Lubricating



Body - 17-4 PH stainless steel (AMS 5342) heat treated.

Ball - 440 C stainless steel (AMS 5630), heat treated, hard chrome plated.

Bushing - 17-4 PH stainless steel, heat treated, PTFE lined.

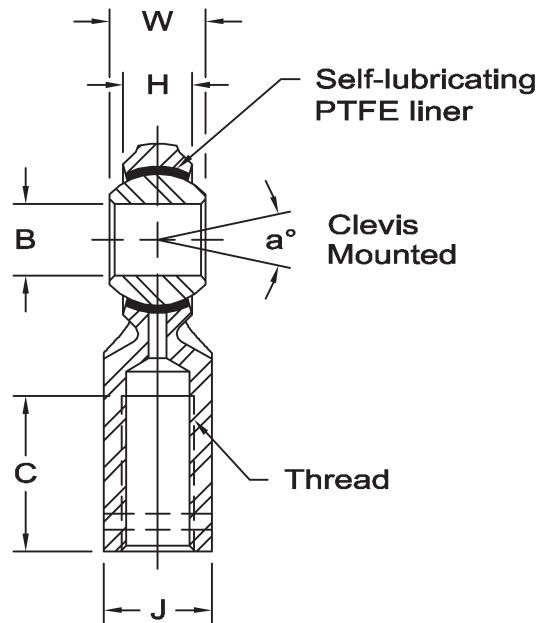
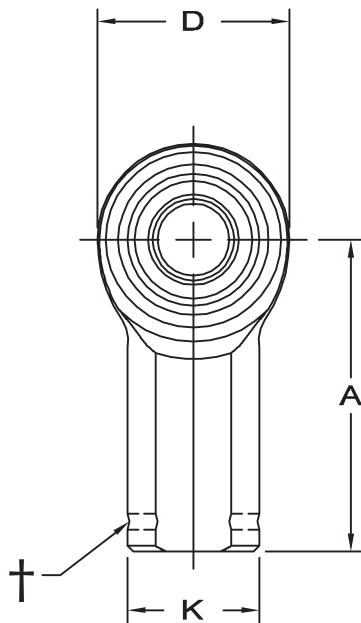

† Left hand units have identification groove near end of shank

ROD END NO.		DIMENSIONS IN INCHES										a° Misalign. Angle	Ultimate Radial Static Load Capacity Lbs.	Approx. Brg. Wt. Lbs.
Right Hand	Left Hand†	B + .0015 - .0005	W + .000 - .005	H Ref.	A ± .015	D Ref.	K ± .010	J ± .010	Ball Dia. Ref.	C + .062 - .031	Thread UNF-2B			
CW-5ET	CG-5ET	.3125	.437	.312	1.375	.875	.500	.437	.593	.687	5/16 24	18	6,451	.08
CW-6ET	CG-6ET	.3750	.500	.359	1.625	1.000	.687	.562	.687	.812	3/8 24	18	8,627	.13
CW-7ET	CG-7ET	.4375	.562	.406	1.812	1.125	.750	.625	.781	.937	7/16 20	17	9,370	.18
CW-8ET	CG-8ET	.5000	.625	.453	2.125	1.312	.875	.750	.875	1.062	1/2 20	16	15,130	.29
CW-10ET	CG-10ET	.6250	.750	.484	2.500	1.500	1.000	.875	1.062	1.375	5/8 18	22	16,922	.43
CW-12ET	CG-12ET	.7500	.875	.593	2.875	1.750	1.125	1.000	1.250	1.562	3/4 16	20	25,549	.65

ROD END NO.		DIMENSIONS IN MILLIMETERS										a° Misalign. Angle	Ultimate Radial Static Load Capacity Newtons	Approx. Brg. Wt. Grams
Right Hand	Left Hand †	B + .038 - .013	W + .00 - .13	H Ref.	A ± .38	D Ref.	K ± .25	J ± .25	Ball Dia. Ref.	C + 1.57 - .79	Thread UNF-2B			
CW-5ET	CG-5ET	7.938	11.10	7.92	34.93	22.23	12.70	11.10	15.06	17.45	5/16 24	18	28,693	36
CW-6ET	CG-6ET	9.525	12.70	9.12	41.28	25.40	17.45	14.27	17.45	20.62	3/8 24	18	38,371	59
CW-7ET	CG-7ET	11.113	14.27	10.31	46.02	28.58	19.05	15.88	19.84	23.80	7/16 20	17	41,676	82
CW-8ET	CG-8ET	12.700	15.88	11.50	53.98	33.32	22.23	19.05	22.23	26.97	1/2 20	16	67,299	132
CW-10ET	CG-10ET	15.875	19.05	12.29	63.50	38.10	25.40	22.23	26.97	34.93	5/8 18	22	75,271	195
CW-12ET	CG-12ET	19.050	22.23	15.06	73.03	44.45	28.58	25.40	31.75	39.67	3/4 16	20	113,642	295



SM & SB SERIES MALE ROD ENDS

Corrosion Resistant – Precision (PTFE Liners Available)

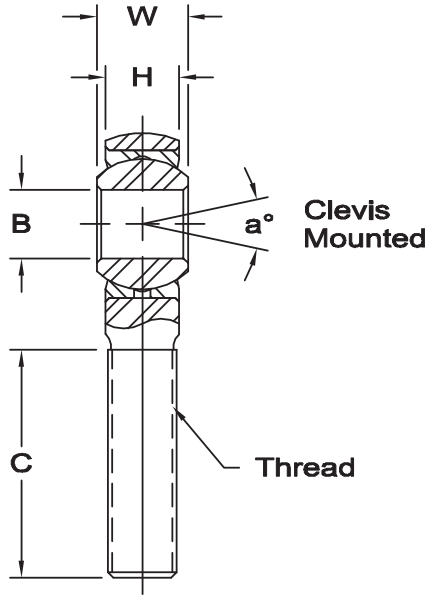
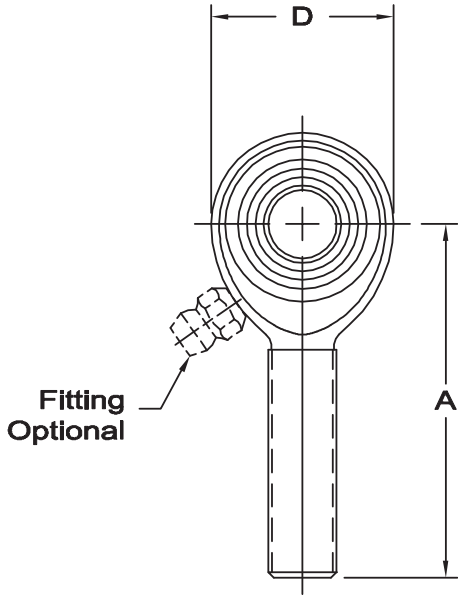

Body - Carbon steel, Electroless nickel plated.

Race - Stainless steel, heat treated.

Ball - Alloy steel, heat treated, hard chrome plated.

Notes - All sizes available with studs upon request.

Load ratings apply only to rod ends without grease fittings. For load ratings with fittings, please consult our engineering department.

Units are supplied without grease fittings. When a grease fitting is required, specify by adding suffix as designated.

- Z Zerk type fitting
- F Flush type fitting
- T PTFE liner

- Ex: SM 6Z
- Ex: SM 6F
- Ex: SM 6T

ROD END NO.		DIMENSIONS IN INCHES								a° Misalign. Angle	Ultimate Radial Static Load Capacity Lbs.	Approx. Brg. Wt. Lbs.
Right Hand	Left Hand	B + .0015 - .0005	W + .000 - .005	H ± .005	A ± .015	D ± .010	Ball Dia. Ref.	C + .062 - .031	Thread UNF-3A			
SM-3	SB-3	.1900	.312	.250	1.250	.625	.437	.750	10 32	13	1,169	.03
SM-4	SB-4	.2500	.375	.281	1.562	.750	.500	1.000	1/4 28	16	2,158	.04
SM-5	SB-5	.3125	.437	.344	1.875	.875	.625	1.250	5/16 24	14	2,784	.07
SM-6	SB-6	.3750	.500	.406	1.938	1.000	.719	1.250	3/8 24	12	3,915	.11
SM-7	SB-7	.4375	.562	.437	2.125	1.125	.812	1.375	7/16 20	14	4,218	.16
SM-8	SB-8	.5000	.625	.500	2.438	1.312	.937	1.500	1/2 20	12	6,660	.25
SM-10	SB-10	.6250	.750	.562	2.625	1.500	1.125	1.625	5/8 18	16	7,364	.38
SM-12	SB-12	.7500	.875	.687	2.875	1.750	1.312	1.750	3/4 16	14	11,518	.60

ROD END NO.		DIMENSIONS IN MILLIMETERS								a° Misalign. Angle	Ultimate Radial Static Load Capacity Newtons	Approx. Brg. Wt. Grams
Right Hand	Left Hand	B + .038 - .013	W + .00 - .13	H ± .13	A + .38	D ± .25	Ball Dia. Ref.	C + 1.57 - .79	Thread UNF-3A			
SM-3	SB-3	4.826	7.92	6.35	31.75	15.88	11.10	19.05	10 32	13	5,197	13
SM-4	SB-4	6.350	9.53	7.14	39.67	19.05	12.70	25.40	1/4 28	16	9,600	20
SM-5	SB-5	7.938	11.10	8.74	47.63	22.23	15.88	31.75	5/16 24	14	12,385	33
SM-6	SB-6	9.525	12.70	10.31	49.23	25.40	18.26	31.75	3/8 24	12	17,416	51
SM-7	SB-7	11.113	14.27	11.10	53.98	28.58	20.62	34.93	7/16 20	14	18,759	73
SM-8	SB-8	12.700	15.88	12.70	61.93	33.32	23.80	38.10	1/2 20	12	29,624	113
SM-10	SB-10	15.875	19.05	14.27	66.68	38.10	28.58	41.28	5/8 18	16	32,752	173
SM-12	SB-12	19.050	22.23	17.45	73.03	44.45	33.32	44.45	3/4 16	14	51,237	273

SW & SG SERIES FEMALE ROD ENDS

Corrosion Resistant – Precision (PTFE Liners Available)



Body - Carbon steel,
Electroless nickel
plated.

Race - Stainless steel,
heat treated.

Ball - Alloy steel, heat
treated, hard chrome
plated.

Notes - All sizes
available with studs
upon request.

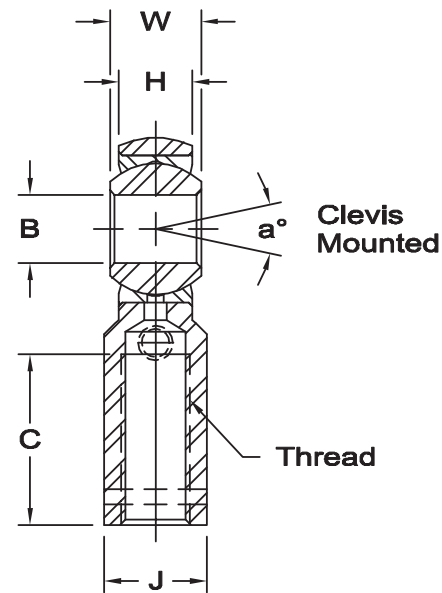
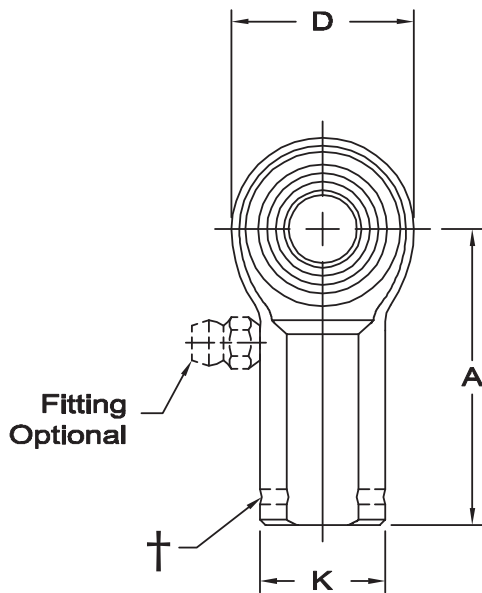

† Left hand units have identification groove near end of shank.

Units are supplied without grease fittings. When a grease fitting is required, specify by adding suffix as designated.

Z Zerk type fitting Ex: SW 6Z
F Flush type fitting Ex: SW 6F
T PTFE liner Ex: SW 6T

ROD END NO.		DIMENSIONS IN INCHES										a° Misalign. Angle	Ultimate Radial Static Load Capacity Lbs.	Approx. Brg. Wt. Lbs.
Right Hand	Left Hand†	B +.0015 -.0005	W +.000 -.005	H ±.005	A ±.015	D ±.010	K ±.010	J ±.010	Ball Dia. Ref.	C +.062 -.031	Thread UNF-2B			
SW-3	SG-3	.1900	.312	.250	1.062	.625	.406	.312	.437	.562	10 32	13	1,531	.04
SW-4	SG-4	.2500	.375	.281	1.312	.750	.469	.375	.500	.750	1/4 28	16	2,539	.06
SW-5	SG-5	.3125	.437	.344	1.375	.875	.500	.437	.625	.750	5/16 24	14	3,133	.09
SW-6	SG-6	.3750	.500	.406	1.625	1.000	.687	.562	.719	.937	3/8 24	12	3,915	.15
SW-7	SG-7	.4375	.562	.437	1.812	1.125	.750	.625	.812	1.062	7/16 20	14	4,218	.20
SW-8	SG-8	.5000	.625	.500	2.125	1.312	.875	.750	.937	1.187	1/2 20	12	6,660	.33
SW-10	SG-10	.6250	.750	.562	2.500	1.500	1.000	.875	1.125	1.500	5/8 18	16	7,364	.48
SW-12	SG-12	.7500	.875	.687	2.875	1.750	1.125	1.000	1.312	1.750	3/4 16	14	11,518	.72

ROD END NO.		DIMENSIONS IN MILLIMETERS										a° Misalign. Angle	Ultimate Radial Static Load Capacity Newtons	Approx. Brg. Wt. Grams
Right Hand	Left Hand†	B +.038 -.013	W +.00 -.13	H ±.13	A ±.38	D ±.25	K ±.25	J ±.25	Ball Dia. Ref.	C + 1.57 -.79	Thread UNF-2B			
SW-3	SG-3	4.826	7.92	6.35	26.97	15.88	10.31	7.92	11.10	14.27	10 32	13	6,805	17
SW-4	SG-4	6.350	9.53	7.14	33.32	19.05	11.91	9.53	12.70	19.05	1/4 28	16	11,297	27
SW-5	SG-5	7.938	11.10	8.74	34.93	22.23	12.70	11.10	15.88	19.05	5/16 24	14	13,934	42
SW-6	SG-6	9.525	12.70	10.31	41.28	25.40	17.45	14.27	18.26	23.80	3/8 24	12	17,416	69
SW-7	SG-7	11.113	14.27	11.10	46.02	28.58	19.05	15.88	20.62	26.97	7/16 20	14	18,759	90
SW-8	SG-8	12.700	15.88	12.70	53.98	33.32	22.23	19.05	23.80	30.15	1/2 20	12	29,624	149
SW-10	SG-10	15.875	19.05	14.27	63.50	38.10	25.40	22.23	28.58	38.10	5/8 18	16	32,752	216
SW-12	SG-12	19.050	22.23	17.45	73.03	44.45	28.58	25.40	33.32	44.45	3/4 16	14	51,237	328



SM-E & SB-E SERIES STAINLESS STEEL MALE ROD ENDS

Corrosion Resistant – Precision (PTFE Liners Available)



Body - 17-4 PH stainless steel (AMS 5643), heat treated.

Race - 17-4 PH stainless steel (AMS 5643), heat treated.

Ball - 440 C stainless steel (AMS 5630), heat treated, hard chrome plated.

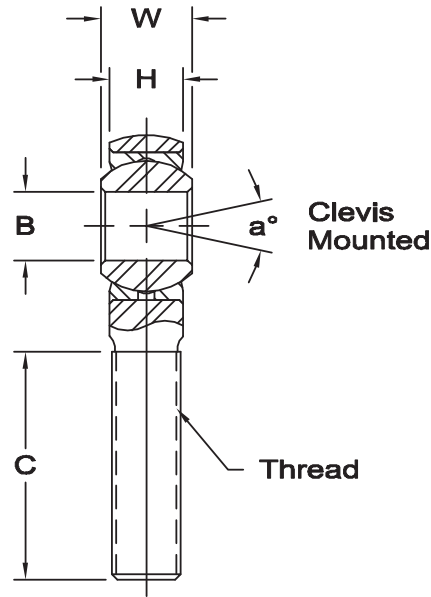
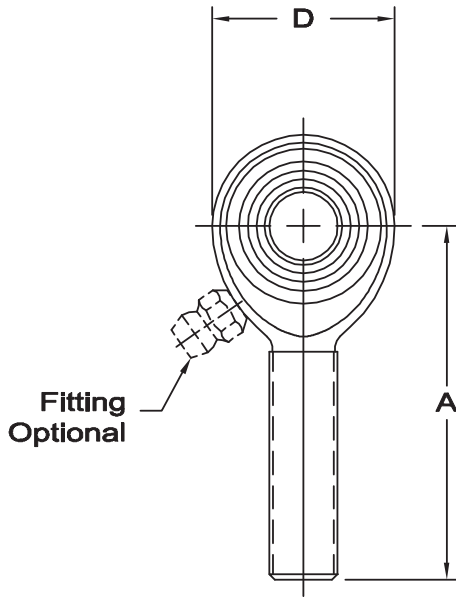

1 Tolerance variation: "D" ± .020, "A" ± .020, "H" ± .010
 2 Tolerance variation: "D" ± .51, "A" ± .51, "H" ± .25

Units are supplied without grease fittings. When a grease fitting is required, specify by adding suffix as designated.

- Z Zerk type fitting Ex: SM 6EZ
- F Flush type fitting Ex: SM 6EF
- T PTFE liner Ex: SM 6ET

Load ratings apply only to rod ends without grease fittings. For load ratings with fittings, please consult our engineering department.

ROD END NO.		DIMENSIONS IN INCHES								a° Misalign. Angle	Ultimate Radial Static Load Capacity Lbs.	Approx. Brg. Wt. Lbs.
Right Hand	Left Hand	B + .0015 - .0005	W + .000 - .005	H ± .005	A ± .015	D ± .010	Ball Dia. Ref.	C + .062 - .031	Thread UNF-3A			
SM-3E	SB-3E	.1900	.312	.250	1.250	.625	.437	.750	10 32	13	2,199	.03
SM-4E	SB-4E	.2500	.375	.281	1.562	.750	.500	1.000	1/4 28	16	4,058	.04
SM-5E	SB-5E	.3125	.437	.344	1.875	.875	.625	1.250	5/16 24	14	5,929	.07
SM-6E	SB-6E	.3750	.500	.406	1.938	1.000	.719	1.250	3/8 24	12	7,363	.11
SM-7E	SB-7E	.4375	.562	.437	2.125	1.125	.812	1.375	7/16 20	14	7,934	.16
SM-8E	SB-8E	.5000	.625	.500	2.438	1.312	.937	1.500	1/2 20	12	12,527	.25
SM-10E	SB-10E	.6250	.750	.562	2.625	1.500	1.125	1.625	5/8 18	16	13,851	.38
SM-12E	SB-12E	.7500	.875	.687	2.875	1.750	1.312	1.750	3/4 16	14	21,664	.60
1 SM-16E	SB-16E	1.000	1.375	1.000	4.125	2.750	1.875	2.125	1 1/4 12	17	72,947	2.41

ROD END NO.		DIMENSIONS IN MILLIMETERS								a° Misalign. Angle	Ultimate Radial Static Load Capacity Newtons	Approx. Brg. Wt. Grams
Right Hand	Left Hand	B + .038 - .013	W + .00 - .13	H ± .13	A ± .38	D ± .25	Ball Dia. Ref.	C + 1.57 - .79	Thread UNF-3A			
SM-3E	SB-3E	4.826	7.92	6.35	31.75	15.88	11.10	19.05	10 32	13	9,781	13
SM-4E	SB-4E	6.350	9.53	7.14	39.67	19.05	12.70	25.40	1/4 28	16	18,050	20
SM-5E	SB-5E	7.938	11.10	8.74	47.63	22.23	15.88	31.75	5/16 24	14	26,372	33
SM-6E	SB-6E	9.525	12.70	10.31	49.23	25.40	18.26	31.75	3/8 24	12	32,751	51
SM-7E	SB-7E	11.113	14.27	11.10	53.98	28.58	20.62	34.93	7/16 20	14	35,290	73
SM-8E	SB-8E	12.700	15.88	12.70	61.93	33.32	23.80	38.10	1/2 20	12	55,720	113
SM-10E	SB-10E	15.875	19.05	14.27	66.68	38.10	28.58	41.28	5/8 18	16	61,609	173
SM-12E	SB-12E	19.050	22.23	17.45	73.03	44.45	33.32	44.45	3/4 16	14	96,361	273
2 SM-16E	SB-16E	25.400	34.93	25.40	104.78	69.85	47.63	53.98	1 1/4 12	17	324,468	1,091

SW-E & SG-E SERIES STAINLESS STEEL FEMALE ROD ENDS

Corrosion Resistant – Precision (PTFE Liners Available)



Body - 17-4 PH stainless steel (AMS 5643), heat treated.

Race - 17-4 PH stainless steel (AMS 5643), heat treated.

Ball - 440 C stainless steel (AMS 5630), heat treated, hard chrome plated.

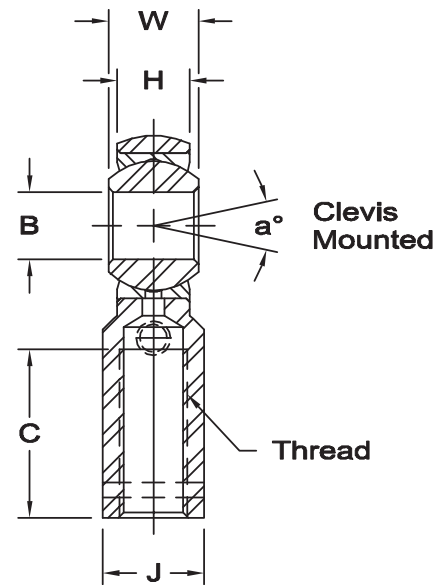
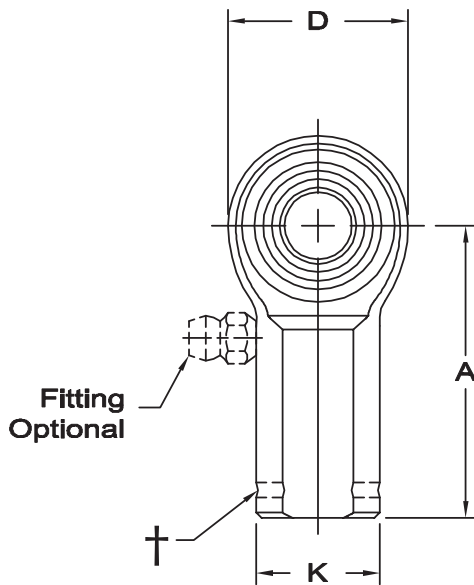

- † Left hand units have identification groove near end of shank
- 1 Tolerance variation: "D" ± .020, "A" ± .020, "H" ± .010, "J" ± .015, "K" ± .015
- 2 Tolerance variation: "D" ± .51, "A" ± .51, "H" ± .25, "J" ± .38, "K" ± .38
- 3 Notes 1 and 2 both have UNF 2B threads.

Units are supplied without grease fittings. When a grease fitting is required, specify by adding suffix as designated.
 Z Zerk type fitting Ex: SW 6EZ
 F Flush type fitting Ex: SW 6EF
 T PTFE liner Ex: SW 6ET

ROD END NO.		DIMENSIONS IN INCHES										a° Misalign. Angle	Ultimate Radial Static Load Capacity Lbs.	Approx. Brg. Wt. Lbs.
Right Hand	Left Hand†	B + .0015 - .0005	W + .000 - .005	H ± .005	A ± .015	D ± .010	K ± .010	J ± .010	Ball Dia. Ref.	C + .062 - .031	Thread UNF-3B			
SW-3E	SG-3E	.1900	.312	.250	1.062	.625	.406	.312	.437	.562	10 32	13	2,895	.04
SW-4E	SG-4E	.2500	.375	.281	1.312	.750	.469	.375	.500	.750	1/4 28	16	4,795	.06
SW-5E	SG-5E	.3125	.437	.344	1.375	.875	.500	.437	.625	.750	5/16 24	14	5,929	.09
SW-6E	SG-6E	.3750	.500	.406	1.625	1.000	.687	.562	.719	.937	3/8 24	12	7,363	.15
SW-7E	SG-7E	.4375	.562	.437	1.812	1.125	.750	.625	.812	1.062	7/16 20	14	7,934	.20
SW-8E	SG-8E	.5000	.625	.500	2.125	1.312	.875	.750	.937	1.187	1/2 20	12	12,527	.33
SW-10E	SG-10E	.6250	.750	.562	2.500	1.500	1.000	.875	1.125	1.500	5/8 18	16	13,851	.48
SW-12E	SG-12E	.7500	.875	.687	2.875	1.750	1.125	1.000	1.312	1.750	3/4 16	14	21,664	.72
1 SW-16E	SG-16E	1.0000	1.375	1.000	4.125	2.750	1.625	1.500	1.875	2.125	1 1/4 12	17	61,333	2.13

ROD END NO.		DIMENSIONS IN MILLIMETERS										a° Misalign. Angle	Ultimate Radial Static Load Capacity Newtons	Approx. Brg. Wt. Grams
Right Hand	Left Hand†	B + .038 - .013	W + .00 - .13	H ± .13	A ± .38	D ± .25	K ± .25	J ± .25	Ball Dia. Ref.	C + 1.57 - .79	Thread UNF-3B			
SW-3E	SG-3E	4.826	7.92	6.35	26.97	15.88	10.31	7.92	11.10	14.27	10 32	13	12,877	17
SW-4E	SG-4E	6.350	9.53	7.14	33.32	19.05	11.91	9.53	12.70	19.05	1/4 28	16	21,328	27
SW-5E	SG-5E	7.938	11.10	8.74	34.93	22.23	12.70	11.10	15.88	19.05	5/16 24	14	26,372	42
SW-6E	SG-6E	9.525	12.70	10.31	41.28	25.40	17.45	14.27	18.26	23.80	3/8 24	12	32,751	69
SW-7E	SG-7E	11.113	14.27	11.10	46.02	28.58	19.05	15.88	20.62	26.97	7/16 20	14	35,290	90
SW-8E	SG-8E	12.700	15.88	12.70	53.98	33.32	22.23	19.05	23.80	30.15	1/2 20	12	55,720	149
SW-10E	SG-10E	15.875	19.05	14.27	63.50	38.10	25.40	22.23	28.58	38.10	5/8 18	16	61,609	216
SW-12E	SG-12E	19.050	22.23	17.45	73.03	44.45	28.58	25.40	33.32	44.45	3/4 16	14	96,361	328
2 SW-16E	SG-16E	25.400	34.93	25.40	104.78	69.85	41.28	38.10	47.63	53.98	1 1/4 12	17	272,809	964



ROD END STUDS

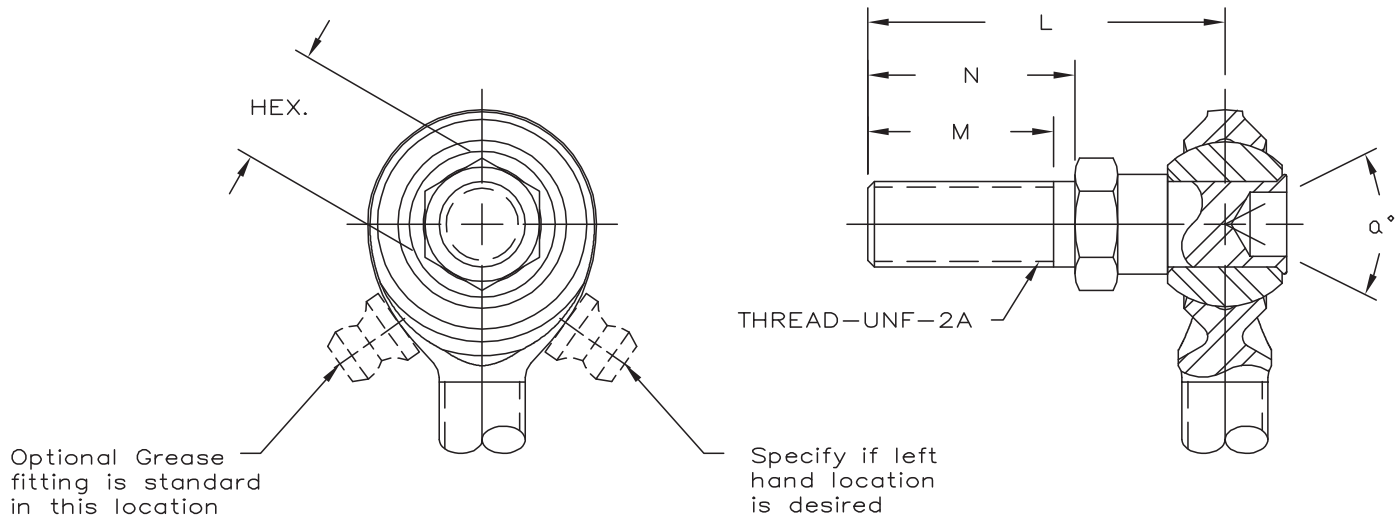

NOTES:

1. Stud configuration is shown as a 2-piece male, but is also available in 2-piece female, most 3-piece male and female configurations, and the AIB, MIB, and SIB spherical bearing configurations. Studs are specifically not available in the HXAM and COM series.
2. Grease fittings are not available on the CM-3S, CM-4S, CM-5S, or CW-3S rod ends. Units are supplied without grease fittings. When grease fittings are required, specify by adding suffix Z or F. (ex.: CM-8SZ)
3. The standard grease fitting location (right hand location) is configured with the stud facing away from you while holding the rod end. If fitting must be oriented on the opposite side of the rod end, specify the left hand location.
4. The ultimate radial static load capacity is based on the shear strength of the stud.
5. Thread UNC-2A
6. Stud sizes 3 through 12 are normally stocked, size 2 and 16 are available on special order. Rod ends with studs installed are normally only stocked in the CM/CB series male rod ends, and CW/CG female rod ends. Studs are installed in rod ends of other series on a special order basis.

STUD SIZE	DIMENSIONS IN INCHES					CM/CW Series Total Misalign. Angle	VCM/VCW, CM/CW-ET Series Total Misalign. Angle	3 - Piece Total Misalign. Angle	Ultimate Radial Static Load Capacity Lbs.
	L ±.015	N ±.010	M Ref.	Hex Size Ref.	Thread UNF-2A				
2	.875	.500	.437	.250	.1380 32	N/A	N/A	47	100
3	1.000	.500	.437	.312	.1900 32	45	N/A	40	240
4	1.031	.562	.500	.375	.2500 28	43	N/A	34	442
5	1.219	.687	.593	.438	.3125 24	46	38	39	715
6	1.562	.906	.812	.500	.3750 24	45	38	36	1,014
7	1.750	1.062	.937	.562	.4375 20	44	38	39	1,269
8	2.000	1.125	1.000	.625	.5000 20	48	38	42	1,668
10	2.500	1.500	1.375	.750	.6250 18	54	45	45	1,943
12	3.000	1.812	1.625	.875	.7500 16	50	42	40	2,841
16	3.562	2.000	1.750	1.250	1.0000 12	N/A	N/A	42	8,178

5

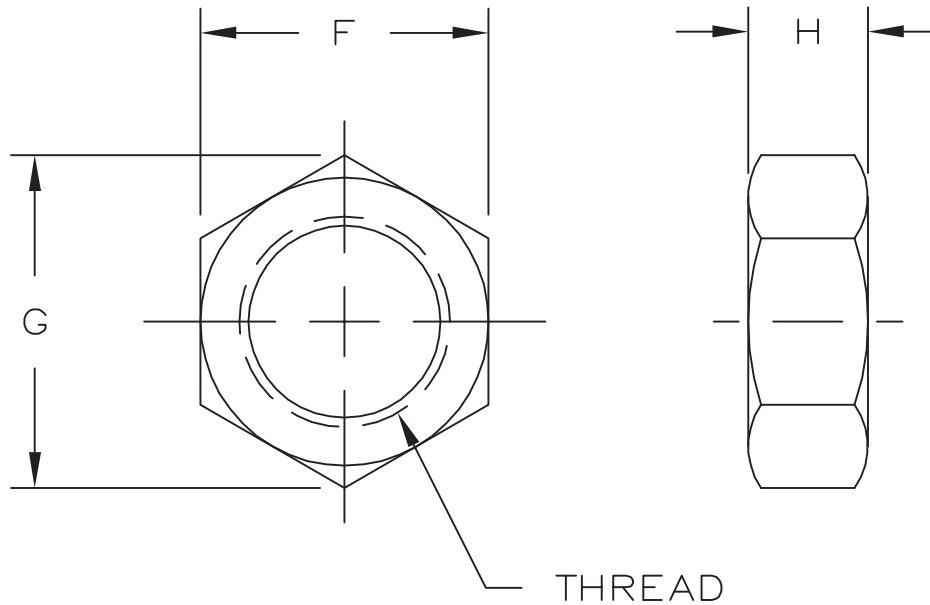

NOTES:

1. Right hand threaded jam nuts are zinc plated clear and left hand threaded jam nuts are zinc plated yellow.

JAM NUT NO.		DIMENSIONS IN INCHES			
Right Hand Thread	Left Hand Thread	Thread UNF-2B	F Ref.	G Ref.	H Ref.
JNR-0332	JNL-0332	.1900 32	.375	.417	.125
JNR-0428	JNL-0428	.2500 28	.438	.505	.156
JNR-0524	JNL-0524	.3125 24	.500	.577	.188
JNR-0624	JNL-0624	.3750 24	.562	.650	.219
JNR-0720	JNL-0720	.4375 20	.688	.794	.250
JNR-0820	JNL-0820	.5000 20	.750	.866	.312
JNR-1018	JNL-1018	.6250 18	.938	1.083	.375
JNR-1216	JNL-1216	.7500 16	1.125	1.299	.422
JNR-1414	JNL-1414	.8750 14	1.312	1.516	.484
JNR-1612	JNL-1612	1.0000 12	1.500	1.732	.547
JNR-1614	JNL-1614	1.0000 14	1.500	1.732	.547
JNR-2012	JNL-2012	1.2500 12	1.875	2.165	.719
JNR-2412	JNL-2412	1.5000 12	2.250	2.598	.844
JNR-3212	JNL-3212	2.0000 12	3.125	3.608	1.094

JAM NUT NO.		DIMENSIONS IN MILLIMETERS			
Right Hand Thread	Left Hand Thread	Thread -6H	F Ref.	G Ref.	H Ref.
JNR-M5	JNL-M5	M5X0.8	8.00	9.24	2.70
JNR-M6	JNL-M6	M6X1.0	10.00	11.55	3.20
JNRF-M8	JNLF-M8	M8X1.0	13.00	15.01	4.00
JNR-M8	JNL-M8	M8X1.25	13.00	15.01	4.00
JNRF-M10	JNLF-M10	M10X1.25	16.00	18.48	5.00
JNR-M10	JNL-M10	M10X1.5	16.00	18.48	5.00
JNRF-M12	JNLF-M12	M12X1.25	18.00	20.78	6.00
JNR-M12	JNL-M12	M12X1.75	18.00	20.78	6.00
JNRF-M14	JNLF-M14	M14X1.5	21.00	24.25	7.00
JNR-M14	JNL-M14	M14X2.0	21.00	24.25	7.00
JNRF-M16	JNLF-M16	M16X1.5	24.00	27.71	8.00
JNR-M16	JNL-M16	M16X2.0	24.00	27.71	8.00
JNRF-M20	JNLF-M20	M20X1.5	30.00	34.64	10.00
JNR-M20	JNL-M20	M20X2.5	30.00	34.64	10.00
JNR-M25	JNL-M25	M24X2.0	36.00	41.57	12.00
JNR-M30	JNL-M30	M30X2.0	46.00	53.12	15.00



ROD END LINKAGES

Adjustable or Fixed Centers

Beyond rod ends and spherical bearings for installation into customer components, Aurora Bearing also manufactures linkages on a special order basis. Linkages can be combined with male or female rod ends and the appropriate connector, resulting in linkages with adjustable centers, or the appropriate rod end or spherical insert can be incorporated into a fixed length linkage. Linkages are not normally stocked, and minimum order quantities are required. Virtually all Aurora products, in inch or metric series, can be incorporated in these custom engineered products. Contact Aurora sales for further information.

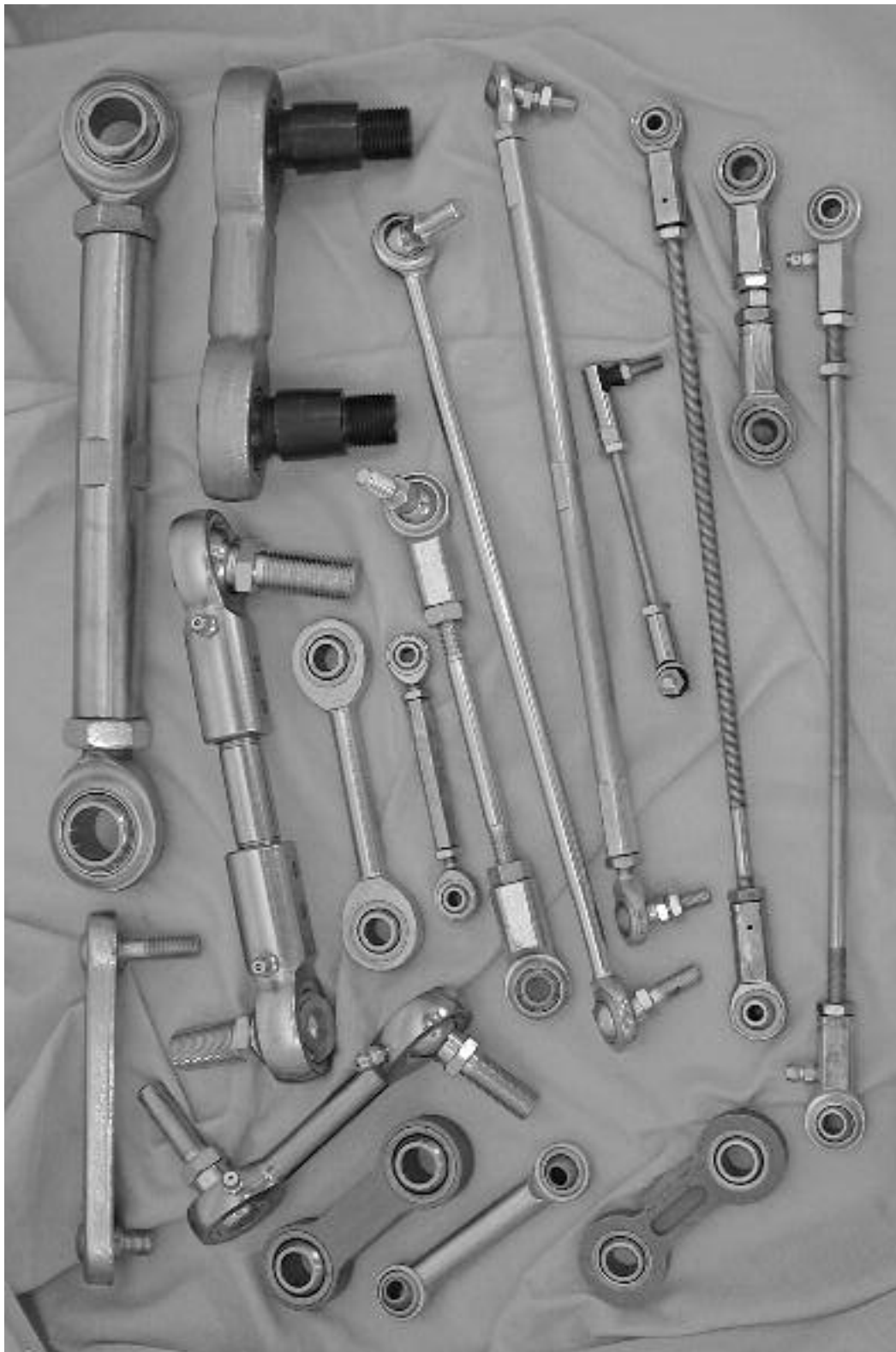

METRIC ROD ENDS

General Purpose – Economy



CM-M & CB-M SERIES MALE ROD ENDS

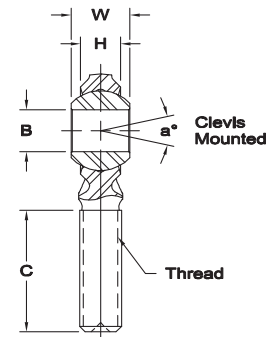
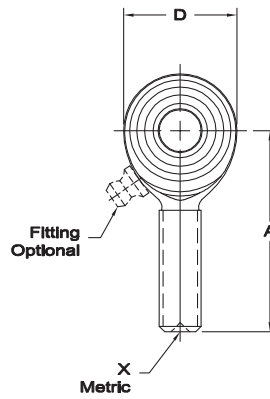

Z Zerk type fitting CM M10Z
(Not available for 3, 5, 6, & 8).

Body - Carbon steel, protective coated for corrosion resistance.

Ball - Alloy steel, heat treated, hard chrome plated.

CW-M & CG-M SERIES FEMALE ROD ENDS

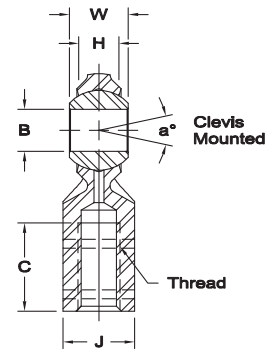
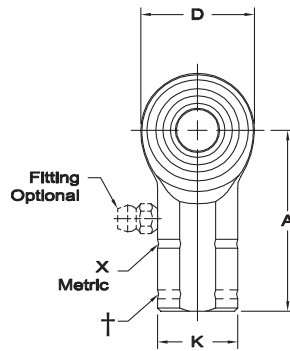

Z Zerk type fitting CW M10Z
(Not available for 3 & 5)

* X Designates metric threads.

†Left hand units have identification groove near end of shank.

MALE

ROD END NO.		DIMENSIONS IN MILLIMETERS								a° Mismatch Angle**			Ultimate Radial Static Load Capacity	Approx. Brg. Wt. Grams	
Right Hand	Left Hand	B + .065 - .013	W ± .13	H Ref.	A ± .40	D Ref.	Ball Dia. Ref.	C ± 1.00	Thread	a ₁	a ₂	a ₃	Newtons		
*	CM-M3	CB-M3	3	6	4.25	27	12.50	7.93	15	M3 X 0.5	23	34			71
*	CM-M5	CB-M5	5	8	5.75	33	16.00	11.10	20	M5 X 0.8	22	30	64	5,168	12
	CM-M6	CB-M6	6	9	6.25	36	19.00	12.70	22	M6 X 1.0	23	31	65	7,296	18
	CM-M8	CB-M8	8	12	8.00	42	22.25	15.88	25	M8 X 1.25	28	38	59	13,591	31
	CM-M10	CB-M10	10	14	9.50	48	27.00	19.05	29	M10 X 1.5	26	35	57	21,024	68
	CM-M12	CB-M12	12	16	10.75	54	30.00	22.23	33	M12 X 1.75	27	34	57	25,819	78
*	CM-M14	CB-M14	14	19	12.25	60	34.75	25.40	36	M14 X 2.0	30	39	55	35,214	118
	CM-M16	CB-M16	16	21	12.75	66	38.00	28.58	40	M16 X 2.0	33	42	59	37,391	173
*	CM-M18	CB-M18	18	23	14.75	72	42.00	31.75	44	M18 X 1.5	30	37	56	47,903	260
	CM-M20	CB-M20	20	25	16.25	78	46.00	34.93	47	M20 X 1.5	29	36	55	57,101	290

FEMALE

ROD END NO.		DIMENSIONS IN MILLIMETERS									a° Mismatch Angle**			Ultimate Radial Static Load Capacity	Approx. Brg. Wt. Grams		
Right Hand	Left Hand†	B + .065 - .013	W ± .13	H Ref.	A ± .40	D Ref.	K ± .25	J ± .25	Ball Dia. Ref.	C ± 1.00	Thread	a ₁	a ₂	a ₃	Newtons		
*	CW-M3	CG-M3	3	6	4.25	21	12.50	8	7	7.93	10	M3 X 0.5	23	34			71
*	CW-M5	CG-M5	5	8	5.75	27	16.00	11	9	11.10	14	M5 X 0.8	22	30	64	8,247	18
	CW-M6	CG-M6	6	9	6.25	30	19.00	13	11	12.70	14	M6 X 1.0	23	31	65	11,895	25
	CW-M8	CG-M8	8	12	8.00	36	22.25	16	14	15.88	17	M8 X 1.25	28	38	59	15,190	40
	CW-M10	CG-M10	10	14	9.50	43	27.00	19	17	19.05	21	M10 X 1.5	26	35	57	22,750	80
	CW-M12	CG-M12	12	16	10.75	50	30.00	22	19	22.23	24	M12 X 1.75	27	34	57	25,819	95
*	CW-M14	CG-M14	14	19	12.25	57	34.75	25	22	25.40	27	M14 X 2.0	30	39	55	35,214	160
	CW-M16	CG-M16	16	21	12.75	64	38.00	27	22	28.58	33	M16 X 2.0	33	42	59	37,391	215
*	CW-M18	CG-M18	18	23	14.75	71	42.00	31	27	31.75	36	M18 X 1.5	30	37	56	47,903	300
	CW-M20	CG-M20	20	25	16.25	77	46.00	34	30	34.93	40	M20 X 1.5	29	36	55	57,101	350



MM-M & MB-M SERIES MALE ROD ENDS - METRIC

General Purpose – Precision (PTFE Liners Available)

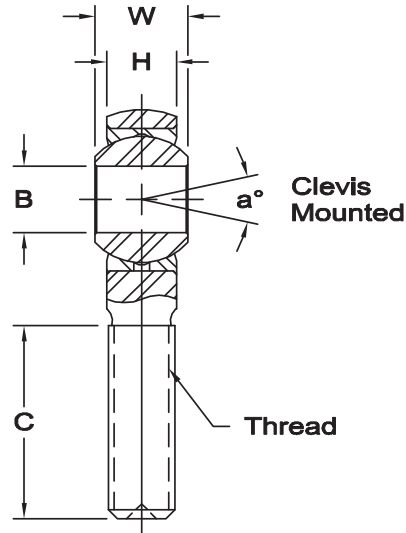
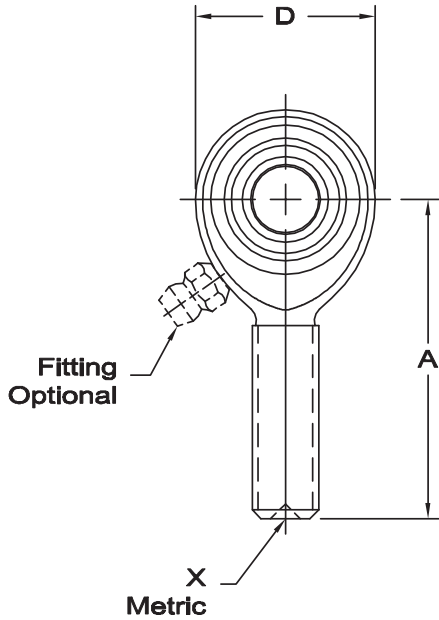

Body - Carbon steel, protective coated for corrosion resistance.

Race - Carbon steel, protective coated for corrosion resistance.

Ball - Alloy steel, heat treated, hard chrome plated.

X Designates metric threads.
1 Tolerance variation: "D" ± .51, "A" ± .51

‡ Grease fitting not available on this size. Units are supplied without grease fittings. When a grease fitting is required, specify by adding suffix as designated.

- Z Zerk type fitting Ex: MM M10Z
- F Flush type fitting Ex: MM M10F
- T PTFE Liner Ex: MM M10T

Load ratings apply only to rod ends without grease fittings. For load ratings with fittings, please consult our engineering department.

ROD END NO.		DIMENSIONS IN MILLIMETERS								a°			Ultimate Radial Static Load Capacity Newtons	Approx. Brg. Wt. Grams	
Right Hand	Left Hand	B +.065 -.013	W ±.13	H ±.13	A ±.40	D ±.38	Ball Dia. Ref.	C ± 1.00	Thread	Misalign. Angle**					
										a ₁	a ₂	a ₃			
* ‡	MM-M3	MB-M3	3	6	4.75	27	12.50	7.93	15	M3 X 0.5	13	25	62	1,775	7
	MM-M5	MB-M5	5	8	6.25	33	16.00	11.10	20	M5 X 0.8	14	24	58	5,168	13
	MM-M6	MB-M6	6	9	7.00	36	19.00	12.70	22	M6 X 1.0	13	23	57	7,296	18
	MMF-M8	MBF-M8	8	12	8.75	42	22.25	15.88	25	M8 X 1.0	18	31	53	13,591	31
	MM-M8	MB-M8	8	12	8.75	42	22.25	15.88	25	M8 X 1.25	18	31	53	13,591	31
	MMF-M10	MBF-M10	10	14	10.50	48	27.00	19.05	29	M10 X 1.25	17	28	50	20,603	68
	MM-M10	MB-M10	10	14	10.50	48	27.00	19.05	29	M10 X 1.5	17	28	50	20,603	68
	MMF-M12	MBF-M12	12	16	12.00	54	30.00	22.23	33	M12 X 1.25	17	27	49	18,215	78
	MM-M12	MB-M12	12	16	12.00	54	30.00	22.23	33	M12 X 1.75	17	27	49	18,215	78
	MMF-M14	MBF-M14	14	19	13.50	60	34.75	25.40	36	M14 X 1.5	21	33	49	29,840	118
	MM-M14	MB-M14	14	19	13.50	60	34.75	25.40	36	M14 X 2.0	21	33	49	29,840	118
	MMF-M16	MBF-M16	16	21	14.25	66	38.00	28.58	40	M16 X 1.5	23	35	52	32,223	173
	MM-M16	MB-M16	16	21	14.25	66	38.00	28.58	40	M16 X 2.0	23	35	52	32,223	173
* ‡	MM-M18	MB-M18	18	23	16.25	72	42.00	31.75	44	M18 X 1.5	21	31	49	41,303	260
	MMF-M20	MBF-M20	20	25	18.00	78	46.00	34.93	47	M20 X 1.5	20	29	48	50,952	290
* ‡	MM-M20	MB-M20	20	25	18.00	78	46.00	34.93	47	M20 X 2.5	20	29	48	50,952	290
* ‡	MM-M22	MB-M22	22	28	19.50	86	50.00	38.10	51	M22 X 1.5	22	33	48	56,238	315
	MM-M25	MB-M25	25	31	22.00	95	60.00	42.86	57	M24 X 2.0	19	31	47	104,435	500
1* ‡	MM-M30	MB-M30	30	37	25.40	104.78	69.85	50.80	60	M30 X 2.0	21	33	47	147,238	1,090

MW-M & MG-M SERIES FEMALE ROD ENDS - METRIC

General Purpose – Precision (PTFE Liners Available)



Body - Carbon steel, protective coated for corrosion resistance.

Race - Carbon steel, protective coated for corrosion resistance.

Ball - Alloy steel, heat treated, hard chrome plated.

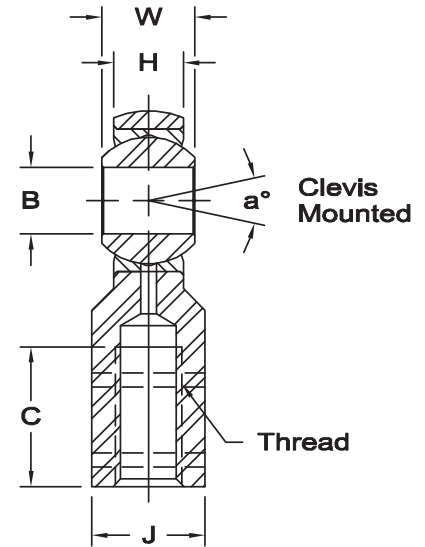
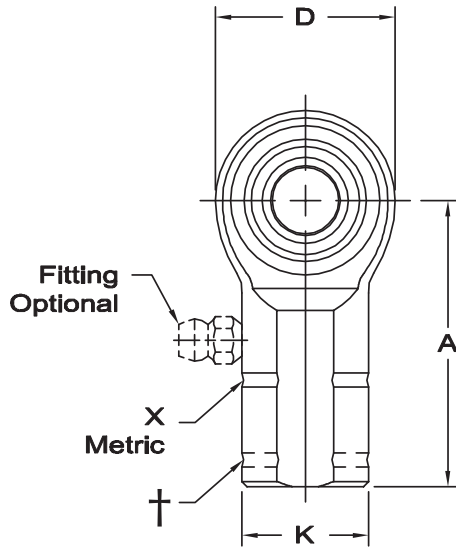

X Designates metric threads.

† Left hand units have identification groove.

1 Tolerance variation: "D" ± .51, "A" ± .51

‡ Grease fitting not available on this size. Units are supplied without grease fittings. When a grease fitting is required, specify by adding suffix as designated.

Z Zerk type fitting Ex: MW M10Z

F Flush type fitting Ex: MW M10F

T PTFE Liner Ex: MW M10T

ROD END NO.		DIMENSIONS IN MILLIMETERS										a°			Ultimate Radial Static Load Capacity Newtons	Approx. Brg. Wt. Grams	
Right Hand	Left Hand†	B + .065 - .013	W ± .13	H ± .13	A ± .40	D ± .38	K ± .25	J ± .25	Ball Dia. Ref.	C ± 1.00	Thread	Misalign. Angle**					
					a ₁	a ₂	a ₃										
* ‡	MW-M3	‡MG-M3	3	6	4.75	21	12.50	8	7	7.93	10	M3 X 0.5	13	25	62	4,972	10
	MW-M5	MG-M5	5	8	6.25	27	16.00	11	9	11.10	14	M5 X 0.8	14	24	58	7,090	17
	MW-M6	MG-M6	6	9	7.00	30	19.00	13	11	12.70	14	M6 X 1.0	13	23	57	10,573	25
	MWF-M8	MGF-M8	8	12	8.75	36	22.25	16	14	15.88	17	M8 X 1.0	18	31	53	14,072	40
	MW-M8	MG-M8	8	12	8.75	36	22.25	16	14	15.88	17	M8 X 1.25	18	31	53	14,072	40
	MWF-M10	MGF-M10	10	14	10.50	43	27.00	19	17	19.05	21	M10 X 1.25	17	28	50	20,603	80
	MW-M10	MG-M10	10	14	10.50	43	27.00	19	17	19.05	21	M10 X 1.5	17	28	50	20,603	80
	MWF-M12	MGF-M12	12	16	12.00	50	30.00	22	19	22.23	24	M12 X 1.25	17	27	49	18,215	95
	MW-M12	MG-M12	12	16	12.00	50	30.00	22	19	22.23	24	M12 X 1.5	17	27	49	18,215	95
	MWF-M14	MGF-M14	14	19	13.50	57	34.75	25	22	25.40	27	M14 X 1.75	21	33	49	29,840	160
	MW-M14	MG-M14	14	19	13.50	57	34.75	25	22	25.40	27	M14 X 2.0	21	33	49	29,840	160
	MWF-M16	MGF-M16	16	21	14.25	64	38.00	27	22	28.58	33	M16 X 1.5	23	35	52	32,223	215
	MW-M16	MG-M16	16	21	14.25	64	38.00	27	22	28.58	33	M16 X 2.0	23	35	52	32,223	215
*	MW-M18	MG-M18	18	23	16.25	71	42.00	31	27	31.75	36	M18 X 1.5	21	31	49	41,303	300
	MWF-M20	MGF-M20	20	25	18.00	77	46.00	34	30	34.93	40	M20 X 1.5	20	29	48	50,952	350
*	MW-M20	MG-M20	20	25	18.00	77	46.00	34	30	34.93	40	M20 X 2.5	20	29	48	50,952	350
*	MW-M22	MG-M22	22	28	19.50	86	50.00	37	32	38.10	43	M22 X 1.5	22	33	48	56,238	390
	MW-M25	MG-M25	25	31	22.00	95	60.00	42	36	42.86	48	M24 X 2.0	19	31	47	104,435	700
1 *	MW-M30	MG-M30	30	37	25.40	104.78	69.85	41.25	38.10	50.80	54	M30 X 2.0	21	33	47	147,238	970



KM-M & KB-M SERIES MALE ROD ENDS - METRIC

Wear Resistant – Precision

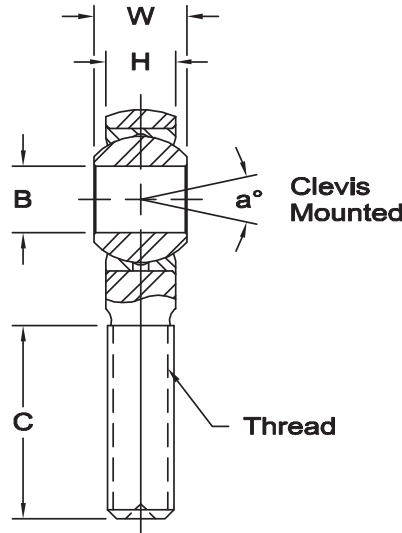
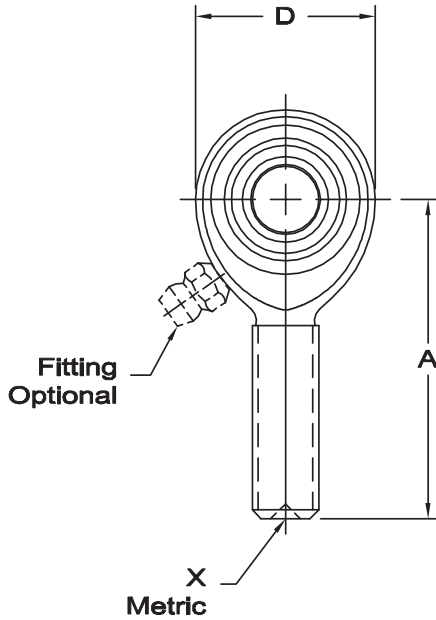

Body - Carbon steel, protective coated for corrosion resistance.

Race - Alloy steel, heat treated, protective coated for corrosion resistance.

Ball - Alloy steel, heat treated, hard chrome plated.

X Designates metric threads.
1 Tolerance variation: "D" ± .51, "A" ± .51

‡ Grease fitting not available on this size. Units are supplied without grease fittings. When a grease fitting is required, specify by adding suffix as designated.

Z Zerk type fitting Ex: KM M10Z
F Flush type fitting Ex: KM M10F

Load ratings apply only to rod ends without grease fittings. For load ratings with fittings, please consult our engineering department.

ROD END NO.		DIMENSIONS IN MILLIMETERS								a°			Ultimate Radial Static Load Capacity Newtons	Approx. Brg. Wt. Grams	
Right Hand	Left Hand	B +.065 -.013	W ± .13	H ± .13	A ± .40	D ± .38	Ball Dia. Ref.	C ± 1.00	Thread	Misalign. Angle**					
										a ₁	a ₂	a ₃			
* ‡	KM-M3	‡KB-M3	3	6	4.75	27	12.50	7.93	15	M3 X 0.5	13	25	62	1,775	7
	KM-M5	KB-M5	5	8	6.25	33	16.00	11.10	20	M5 X 0.8	14	24	58	5,168	13
	KM-M6	KB-M6	6	9	7.00	36	19.00	12.70	22	M6 X 1.0	13	23	57	7,296	18
	KMF-M8	KBF-M8	8	12	8.75	42	22.25	15.88	25	M8 X 1.0	18	31	53	13,591	31
	KM-M8	KB-M8	8	12	8.75	42	22.25	15.88	25	M8 X 1.25	18	31	53	13,591	31
	KMF-M10	KBF-M10	10	14	10.50	48	27.00	19.05	29	M10 X 1.25	17	28	50	20,603	68
	KM-M10	KB-M10	10	14	10.50	48	27.00	19.05	29	M10 X 1.5	17	28	50	20,603	68
	KMF-M12	KBF-M12	12	16	12.00	54	30.00	22.23	33	M12 X 1.25	17	27	49	18,215	78
	KM-M12	KB-M12	12	16	12.00	54	30.00	22.23	33	M12 X 1.75	17	27	49	18,215	78
	KMF-M14	KBF-M14	14	19	13.50	60	34.75	25.40	36	M14 X 1.5	21	33	49	29,840	118
* ‡	KM-M14	KB-M14	14	19	13.50	60	34.75	25.40	36	M14 X 2.0	21	33	49	29,840	118
	KMF-M16	KBF-M16	16	21	14.25	66	38.00	28.58	40	M16 X 1.5	23	35	52	32,223	173
	KM-M16	KB-M16	16	21	14.25	66	38.00	28.58	40	M16 X 2.0	23	35	52	32,223	173
* ‡	KM-M18	KB-M18	18	23	16.25	72	42.00	31.75	44	M18 X 1.5	21	31	49	41,303	260
	KMF-M20	KBF-M20	20	25	18.00	78	46.00	34.93	47	M20 X 1.5	20	29	48	50,952	290
* ‡	KM-M20	KB-M20	20	25	18.00	78	46.00	34.93	47	M20 X 2.5	20	29	48	50,952	290
* ‡	KM-M22	KB-M22	22	28	19.50	86	50.00	38.10	51	M22 X 1.5	22	33	48	56,238	315
* ‡	KM-M25	KB-M25	25	31	22.00	95	60.00	42.86	57	M24 X 2.0	19	31	47	104,435	500
1 * ‡	KM-M30	KB-M30	30	37	25.40	104.78	69.85	50.80	60	M30 X 2.0	21	33	47	147,238	1,090

KW-M & KG-M SERIES FEMALE ROD ENDS - METRIC

Wear Resistant – Precision



Body - Carbon steel, protective coated for corrosion resistance.

Race - Alloy steel, heat treated, protective coated for corrosion resistance.

Ball - Alloy steel, heat treated, hard chrome plated.

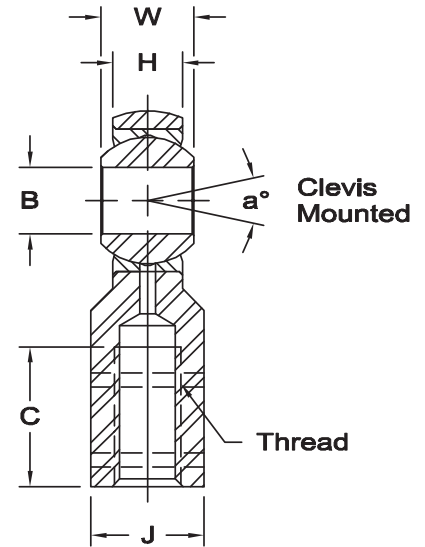
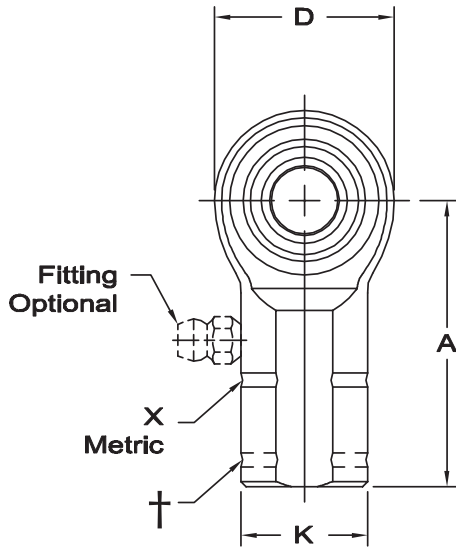

X Designates metric threads.

† Left hand units have identification groove.

1 Tolerance variation: "D" ± .51, "A" ± .51

‡ Grease fitting not available on this size. Units are supplied without grease fittings. When a grease fitting is required, specify by adding suffix as designated.

Z Zerk type fitting Ex: KW M10Z

F Flush type fitting Ex: KW M10F

ROD END NO.		DIMENSIONS IN MILLIMETERS											a°			Ultimate Radial Static Load Capacity Newtons	Approx. Brg. Wt. Grams
Right Hand	Left Hand†	B +.065 -.013	W ± .13	H ± .13	A ± .40	D ± .38	K ± .25	J ± .25	Ball Dia. Ref.	C ± 1.00	Thread	Misalign. Angle**					
												a ₁	a ₃	a _i			
*	‡KW-M3	‡KG-M3	3	6	4.75	21	12.50	8	7	7.93	10	M3 X 0.5	13	25	62	4,972	10
	KW-M5	KG-M5	5	8	6.25	27	16.00	11	9	11.10	14	M5 X 0.8	14	24	58	7,090	17
	KW-M6	KG-M6	6	9	7.00	30	19.00	13	11	12.70	14	M6 X 1.0	13	23	57	10,573	25
	KWF-M8	KGF-M8	8	12	8.75	36	22.25	16	14	15.88	17	M8 X 1.0	18	31	53	14,072	40
	KW-M8	KG-M8	8	12	8.75	36	22.25	16	14	15.88	17	M8 X 1.25	18	31	53	14,072	40
	KWF-M10	KGF-M10	10	14	10.50	43	27.00	19	17	19.05	21	M10 X 1.25	17	28	50	20,603	80
	KW-M10	KG-M10	10	14	10.50	43	27.00	19	17	19.05	21	M10 X 1.5	17	28	50	20,603	80
	KWF-M12	KGF-M12	12	16	12.00	50	30.00	22	19	22.23	24	M12 X 1.25	17	27	49	18,215	95
	KW-M12	KG-M12	12	16	12.00	50	30.00	22	19	22.23	24	M12 X 1.75	17	27	49	18,215	95
	KWF-M14	KGF-M14	14	19	13.50	57	34.75	25	22	25.40	27	M14 X 1.5	21	33	49	29,840	160
*	KW-M14	KG-M14	14	19	13.50	57	34.75	25	22	25.40	27	M14 X 2.0	21	33	49	29,840	160
	KWF-M16	KGF-M16	16	21	14.25	64	38.00	27	22	28.58	33	M16 X 1.5	23	35	52	32,223	215
	KW-M16	KG-M16	16	21	14.25	64	38.00	27	22	28.58	33	M16 X 2.0	23	35	52	32,223	215
*	KW-M18	KG-M18	18	23	16.25	71	42.00	31	27	31.75	36	M18 X 1.5	21	31	49	41,303	300
	KWF-M20	KGF-M20	20	25	18.00	77	46.00	34	30	34.93	40	M20 X 1.5	20	29	48	50,952	350
*	KW-M20	KG-M20	20	25	18.00	77	46.00	34	30	34.93	40	M20 X 2.5	20	29	48	50,952	350
*	KW-M22	KG-M22	22	28	19.50	86	50.00	37	32	38.10	43	M22 X 1.5	22	33	48	56,238	390
*	KW-M25	KG-M25	25	31	22.00	95	60.00	42	36	42.86	48	M24 X 2.0	19	31	47	104,435	700
1	* KW-M30	KG-M30	30	37	25.40	104.78	69.85	41.25	38.10	50.80	54	M30 X 2.0	21	33	47	147,238	970



AM-M & AB-M SERIES MALE ROD ENDS - METRIC

High Strength Alloy – Precision – (PTFE Liners Available)

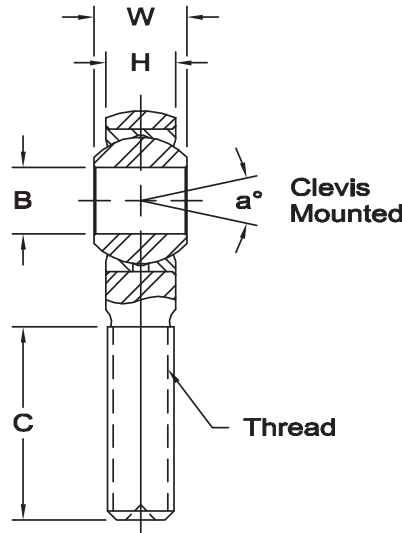
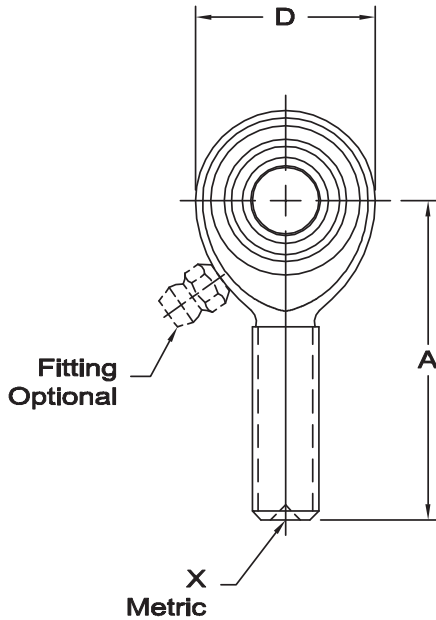

Body - Alloy steel, heat treated, protective coated for corrosion resistance.

Race - Alloy steel, heat treated, protective coated for corrosion resistance.

Ball - Alloy steel, heat treated, hard chrome plated.

X Designates metric threads.
 1 Tolerance variation: "D" ± .51, "A" ± .51

‡ Grease fitting not available on this size. Units are supplied without grease fittings. When a grease fitting is required, specify by adding suffix as designated.

Z Zerk type fitting Ex: AM M10Z
 F Flush type fitting Ex: AM M10F
 T PTFE Liner Ex: AM M10T

ROD END NO.		DIMENSIONS IN MILLIMETERS								a°			Ultimate Radial Static Load Capacity Newtons	Approx. Brg. Wt. Grams	
Right Hand	Left Hand	B +.065 -.013	W ±.13	H ±.13	A ±.40	D ±.38	Ball Dia. Ref.	C ± 1.00	Thread	Misalign. Angle**					
										a ₁	a ₃	a ₁			
* ‡	AM-M3	AB-M3	3	6	4.75	27	12.50	7.93	15	M3 X 0.5	13	25	62	4,344	7
	AM-M5	AB-M5	5	8	6.25	33	16.00	11.10	20	M5 X 0.8	14	24	58	12,611	13
	AM-M6	AB-M6	6	9	7.00	36	19.00	12.70	22	M6 X 1.0	13	23	57	17,720	18
	AMF-M8	ABF-M8	8	12	8.75	42	22.25	15.88	25	M8 X 1.0	18	31	53	33,135	31
	AM-M8	AB-M8	8	12	8.75	42	22.25	15.88	25	M8 X 1.25	18	31	53	33,135	31
	AMF-M10	ABF-M10	10	14	10.50	48	27.00	19.05	29	M10 X 1.25	17	28	50	50,227	68
	AM-M10	AB-M10	10	14	10.50	48	27.00	19.05	29	M10 X 1.5	17	28	50	50,227	68
	AMF-M12	ABF-M12	12	16	12.00	54	30.00	22.23	33	M12 X 1.25	17	27	49	44,490	78
	AM-M12	AB-M12	12	16	12.00	54	30.00	22.23	33	M12 X 1.75	17	27	49	44,490	78
	AMF-M14	ABF-M14	14	19	13.50	60	34.75	25.40	36	M14 X 1.5	21	33	49	71,741	118
* ‡	AM-M14	AB-M14	14	19	13.50	60	34.75	25.40	36	M14 X 2.0	21	33	49	71,741	118
	AMF-M16	ABF-M16	16	21	14.25	66	38.00	28.58	40	M16 X 1.5	23	35	52	76,291	173
* ‡	AM-M16	AB-M16	16	21	14.25	66	38.00	28.58	40	M16 X 2.0	23	35	52	76,291	173
* ‡	AM-M18	AB-M18	18	23	16.25	72	42.00	31.75	44	M18 X 1.5	21	31	49	100,738	260
	AMF-M20	ABF-M20	20	25	18.00	78	46.00	34.93	47	M20 X 1.5	20	29	48	120,212	290
* ‡	AM-M20	AB-M20	20	25	18.00	78	46.00	34.93	47	M20 X 2.5	20	29	48	120,212	290
* ‡	AM-M22	AB-M22	22	28	19.50	86	50.00	38.10	51	M22 X 1.5	22	33	48	137,099	315
* ‡	AM-M25	AB-M25	25	31	22.00	95	60.00	42.86	57	M24 X 2.0	19	31	47	251,780	500
1* ‡	AM-M30	AB-M30	30	37	25.40	104.78	69.85	50.80	60	M30 X 2.0	21	33	47	289,331	1,090

AW-M & AG-M SERIES FEMALE ROD ENDS - METRIC

High Strength Alloy – Precision – (PTFE Liners Available)



Body - Alloy steel, heat treated, protective coated for corrosion resistance.

Race - Alloy steel, heat treated, protective coated for corrosion resistance.

Ball - Alloy steel, heat treated, hard chrome plated.

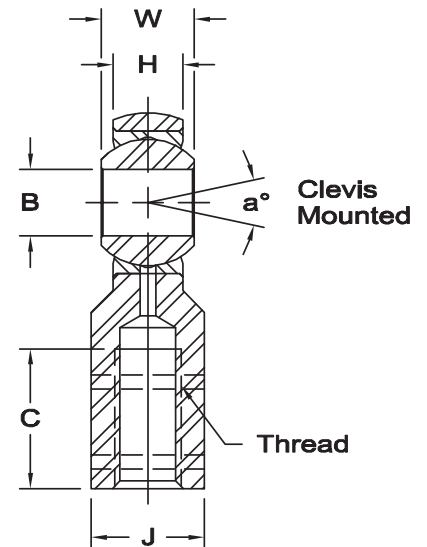
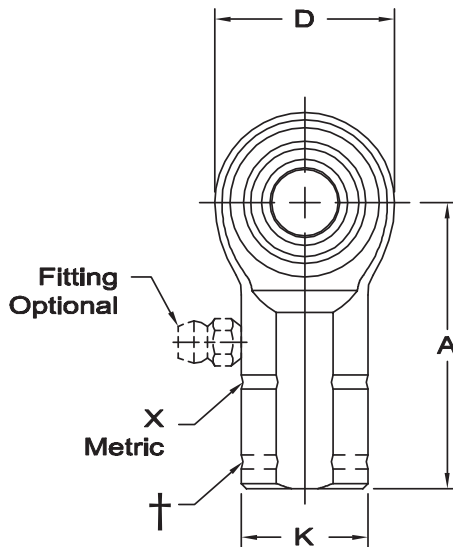

† Left hand units have identification groove near end of shank

X Designates metric threads.

1 Tolerance variation: "D" ± .51, "A" ± .51

‡ Grease fitting not available on this size. Units are supplied without grease fittings. When a grease fitting is required, specify by adding suffix as designated.

Z Zerk type fitting

F Flush type fitting

T PTFE Liner

Ex: AW M10Z

Ex: AW M10F

Ex: AW M10T

ROD END NO.		DIMENSIONS IN MILLIMETERS											a°			Ultimate Radial Static Load Capacity Newtons	Approx. Brg. Wt. Grams
Right Hand	Left Hand	B + .065 - .013	W ± .13	H ± .13	A ± .40	D ± .38	K ± .25	J ± .25	Ball Dia. Ref.	C ± 1.00	Thread	Misalign. Angle**					
												a ₁	a ₂	a ₃			
*	‡AW-M3	‡AG-M3	3	6	4.75	21	12.50	8	7	7.93	10	M3 X 0.5	13	25	62	11,346	10
	AW-M5	AG-M5	5	8	6.25	27	16.00	11	9	11.10	14	M5 X 0.8	14	24	58	16,396	17
	AW-M6	AG-M6	6	9	7.00	30	19.00	13	11	12.70	14	M6 X 1.0	13	23	57	25,781	25
	AWF-M8	AGF-M8	8	12	8.75	36	22.25	16	14	15.88	17	M8 X 1.0	18	31	53	33,203	40
	AW-M8	AG-M8	8	12	8.75	36	22.25	16	14	15.88	17	M8 X 1.25	18	31	53	33,203	40
	AWF-M10	AGF-M10	10	14	10.50	43	27.00	19	17	19.05	21	M10 X 1.25	17	28	50	50,227	80
	AW-M10	AG-M10	10	14	10.50	43	27.00	19	17	19.05	21	M10 X 1.5	17	28	50	50,227	80
	AWF-M12	AGF-M12	12	16	12.00	50	30.00	22	19	22.23	24	M12 X 1.25	17	27	49	44,490	95
	AW-M12	AG-M12	12	16	12.00	50	30.00	22	19	22.23	24	M12 X 1.75	17	27	49	44,490	95
	AWF-M14	AGF-M14	14	19	13.50	57	34.75	25	22	25.40	27	M14 X 1.5	21	33	49	71,741	160
*	AW-M14	AG-M14	14	19	13.50	57	34.75	25	22	25.40	27	M14 X 2.0	21	33	49	71,741	160
	AWF-M16	AGF-M16	16	21	14.25	64	38.00	27	22	28.58	33	M16 X 1.5	23	35	52	76,291	215
*	AW-M16	AG-M16	16	21	14.25	64	38.00	27	22	28.58	33	M16 X 2.0	23	35	52	76,291	215
*	AW-M18	AG-M18	18	23	16.25	71	42.00	31	27	31.75	36	M18 X 1.5	21	31	49	100,738	300
	AWF-M20	AGF-M20	20	25	18.00	77	46.00	34	30	34.93	40	M20 X 1.5	20	29	48	120,212	350
*	AW-M20	AG-M20	20	25	18.00	77	46.00	34	30	34.93	40	M20 X 2.5	20	29	48	120,212	350
*	AW-M22	AG-M22	22	28	19.50	86	50.00	37	32	38.10	43	M22 X 1.5	22	33	48	137,099	390
*	AW-M25	AG-M25	25	31	22.00	95	60.00	42	36	42.86	48	M24 X 2.0	19	31	47	251,780	700
1	* AW-M30	AG-M30	30	37	25.40	104.78	69.85	41.25	38.10	50.80	54	M30 X 2.0	21	33	47	289,331	970



COM-M SERIES SPHERICAL BEARINGS - METRIC

(PTFE Liners Available)¹

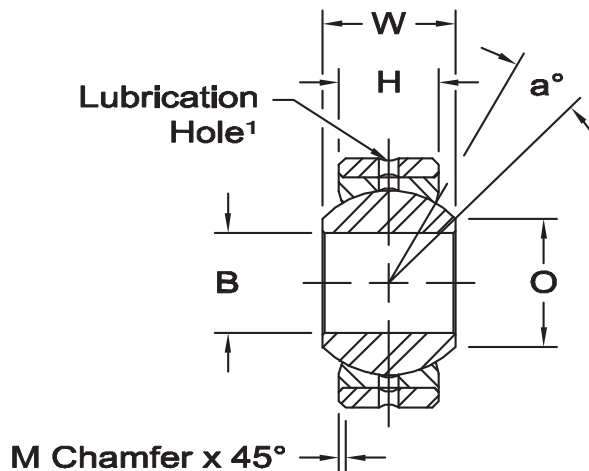
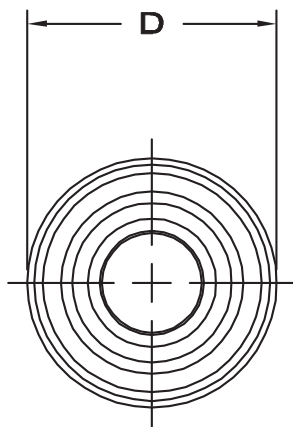

Outer Member -
Carbon steel, protective coated for corrosion resistance.

Race - Carbon steel, I.D. protective coated for corrosion resistance.

Ball - Alloy steel, heat treated, hard chrome plated.

¹ PTFE Liners use suffix T Ex: COM M10T. PTFE lined parts do not have lubrication groove in race.

² Based upon maximum permanent set of .5% of ball O.D.

BEARING NO.	DIMENSIONS IN MILLIMETERS							a° Misalign. Angle	Radial Static Limit Load Capacity Newtons ²	Approx. Brg. Wt. Grams
	B +.065 -.013	D +.000 -.018	H ±.13	W ±.13	O Flat Dia Ref.	M Chamfer Ref.	Ball Dia Ref.			
* COM-M3	3	12	4.50	6	5.19	.5	7.93	13.5	14,758	4
* COM-M5	5	16	6.00	8	7.68	.5	11.10	12.5	27,555	9
COM-M6	6	18	6.75	9	8.93	.5	12.70	12.5	35,459	13
COM-M8	8	22	9.00	12	10.35	.8	15.88	14.0	59,121	24
COM-M10	10	26	10.50	14	12.88	.8	19.05	13.5	82,744	40
COM-M12	12	30	12.00	16	15.39	.8	22.23	13.0	112,829	80
COM-M14	14	34	13.50	19	16.86	1.0	25.40	16.0	141,845	110
COM-M16	16	38	15.00	21	19.34	1.0	28.58	15.0	177,343	130
* COM-M18	18	42	16.50	23	21.89	1.0	31.75	15.0	216,714	170
COM-M20	20	46	18.00	25	24.35	1.0	34.93	14.5	260,086	230
* COM-M22	22	50	20.00	28	25.84	1.5	38.10	15.0	315,216	280
* COM-M25	25	56	22.00	31	29.60	1.5	42.86	15.0	390,056	390
* COM-M30	30	66	25.00	37	34.81	1.5	50.80	17.0	525,360	610

COM & HCOM SERIES SPHERICAL BEARINGS

(PTFE Liners Available)¹

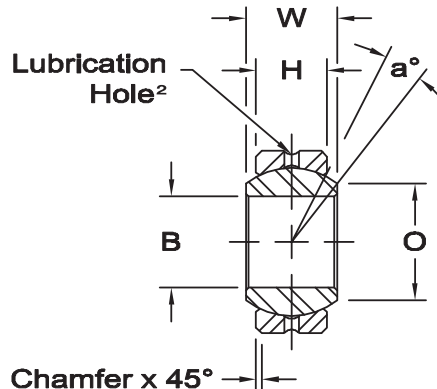
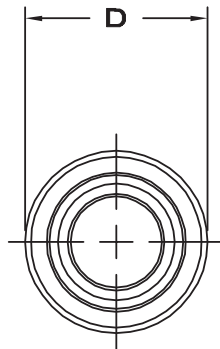

Race - Carbon steel,
I.D. protective coated for
corrosion resistance.

Ball - Alloy steel, heat
treated, hard chrome
plated.

* Bore tolerance on these items is as follows
INCH: +.0025, .0005; METRIC: +.064, .013

¹ PTFE Liners use suffix T Ex: COM 10T

² PTFE Lined parts have no lubrication groove in race.
Hole manufactures option.

BEARING NO.	DIMENSIONS IN INCHES							a° Misalign. Angle	Radial Static Limit Load Capacity Lbs.	Approx. Brg. Wt. Lbs.
	B +.0015 -.0005	D +.0000 -.0007	H ±.005	W ±.005	O Flat Dia Ref.	M Chamfer Ref.	Ball Dia Ref.			
COM-3	.1900	.5625	.218	.281	.293	.015	.406	11	3,250	.01
COM-4	.2500	.6562	.250	.343	.364	.022	.500	13.5	4,950	.02
COM-5	.3125	.7500	.281	.375	.419	.032	.562	12	6,475	.03
COM-6	.3750	.8125	.312	.406	.516	.032	.656	10	8,400	.04
COM-7	.4375	.9062	.343	.437	.530	.032	.687	8	9,453	.05
COM-8	.5000	1.0000	.390	.500	.640	.032	.813	9.5	13,250	.07
COM-9	.5625	1.0937	.437	.562	.710	.032	.906	9.5	16,630	.09
COM-10	.6250	1.1875	.500	.625	.780	.032	1.000	8.5	21,280	.11
COM-12	.7500	1.4375	.593	.750	.920	.044	1.187	9	31,920	.20
COM-14	.8750	1.5625	.703	.875	.980	.044	1.312	9.5	41,960	.26
*COM-16	1.0000	1.7500	.797	1.000	1.118	.044	1.500	10	55,200	.39
*HCOM-16	1.0000	2.0000	.781	1.000	1.360	.032	1.687	9	70,820	.55
*HCOM-19	1.1875	2.3750	.937	1.187	1.610	.032	2.000	8.5	100,730	.90
*HCOM-20	1.2500	2.3750	.937	1.187	1.610	.032	2.000	8.5	100,730	.90
*HCOM-24	1.5000	2.7500	1.094	1.375	1.860	.032	2.312	8.5	135,950	1.36
*HCOM-28	1.7500	3.1250	1.250	1.562	2.110	.044	2.625	8	176,370	1.95
*HCOM-32	2.0000	3.5000	1.375	1.750	2.360	.044	2.937	8.5	217,060	2.65

BEARING NO.	DIMENSIONS IN MILLIMETERS							a° Misalign. Angle	Radial Static Limit Load Capacity Newtons	Approx. Brg. Wt. Grams
	B +.038 -.013	D +.000 -.018	H ±.13	W ±.13	O Flat Dia Ref.	M Chamfer Ref.	Ball Dia Ref.			
COM-3	4.826	14.29	5.54	7.14	7.44	.38	10.31	11	14,464	6
COM-4	6.350	16.67	6.35	8.71	9.25	.56	12.70	13.5	22,015	10
COM-5	7.938	19.05	7.14	9.53	10.64	.81	14.27	12	28,800	14
COM-6	9.525	20.64	7.92	10.31	13.11	.81	16.66	10	37,361	17
COM-7	11.113	23.02	8.71	11.10	13.46	.81	17.45	8	42,048	21
COM-8	12.700	25.40	9.91	12.70	16.26	.81	20.65	9.5	58,934	29
COM-9	14.288	27.78	11.10	14.27	18.03	.81	23.01	9.5	73,967	39
COM-10	15.875	30.16	12.70	15.88	19.81	.81	25.40	8.5	94,658	50
COM-12	19.050	36.51	15.06	19.05	23.37	1.12	30.15	9	141,982	93
COM-14	22.225	39.69	17.86	22.23	24.89	1.12	33.32	9.5	186,639	119
*COM-16	25.400	44.45	20.24	25.40	28.40	1.12	38.10	10	245,534	175
*HCOM-16	25.400	50.80	19.84	25.40	34.54	.81	42.85	9	315,010	251
*HCOM-19	30.163	60.33	23.80	30.15	40.89	.81	50.80	8.5	448,049	406
*HCOM-20	31.750	60.33	23.80	30.15	40.89	.81	50.80	8.5	448,049	406
*HCOM-24	38.100	69.85	27.79	34.93	47.24	.81	58.72	8.5	604,710	616
*HCOM-28	44.450	79.38	31.75	39.67	53.59	1.12	66.68	8	784,495	884
*HCOM-32	50.800	88.90	34.93	44.45	59.94	1.12	74.60	8.5	965,485	1,198



COM-KH & HCOM-KH SERIES SPHERICAL BEARINGS

(PTFE Liners Available)¹

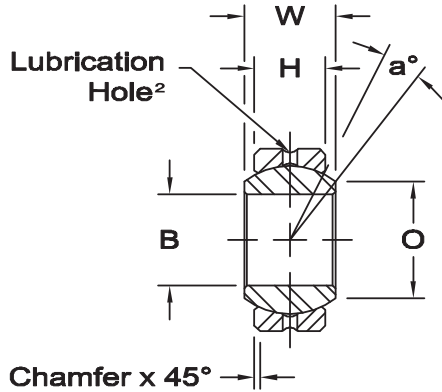
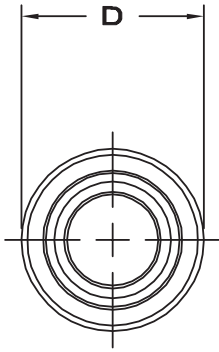

Race - Alloy steel, heat treated, I.D. protective coated for corrosion resistance.

Ball - Alloy steel, heat treated, hard chrome plated.



M Chamfer x 45°

† Bore tolerance on these items is as follows
INCH: +.0025, .0005; METRIC: +.064, .013

¹ PTFE Liners use suffix T Ex: COM 6TKH
² PTFE Lined parts have no lubrication groove in race.
Hole manufactures option.

BEARING NO.	DIMENSIONS IN INCHES							a° Misalign. Angle	Radial Static Limit Load Capacity Lbs.	Approx. Brg. Wt. Lbs.
	B +.0015 -.0005	D +.0000 -.0007	H ±.005	W ±.005	O Flat Dia Ref.	M Chamfer Ref.	Ball Dia Ref.			
* COM-3KH	.1900	.5625	.218	.281	.293	.015	.406	11	4,875	.01
* COM-4KH	.2500	.6562	.250	.343	.364	.022	.500	13.5	7,425	.02
* COM-5KH	.3125	.7500	.281	.375	.419	.032	.562	12	9,713	.03
COM-6KH	.3750	.8125	.312	.406	.516	.032	.656	10	12,600	.04
* COM-7KH	.4375	.9062	.343	.437	.530	.032	.687	8	14,180	.05
* COM-8KH	.5000	1.0000	.390	.500	.640	.032	.813	9.5	19,875	.07
* COM-9KH	.5625	1.0937	.437	.562	.710	.032	.906	9.5	24,945	.09
COM-10KH	.6250	1.1875	.500	.625	.780	.032	1.000	8.5	31,920	.11
COM-12KH	.7500	1.4375	.593	.750	.920	.044	1.187	9	47,880	.20
* COM-14KH	.8750	1.5625	.703	.875	.980	.044	1.312	9.5	62,940	.26
* †COM-16KH	1.0000	1.7500	.797	1.000	1.118	.044	1.500	10	82,800	.39
* †HCOM-16KH	1.0000	2.0000	.781	1.000	1.360	.032	1.687	9	106,230	.55
* †HCOM-19KH	1.1875	2.3750	.937	1.187	1.610	.032	2.000	8.5	151,095	.90
* †HCOM-20KH	1.2500	2.3750	.937	1.187	1.610	.032	2.000	8.5	151,095	.90
* †HCOM-24KH	1.5000	2.7500	1.094	1.375	1.860	.032	2.312	8.5	203,925	1.36
* †HCOM-28KH	1.7500	3.1250	1.250	1.562	2.110	.044	2.625	8	264,555	1.95
* †HCOM-32KH	2.0000	3.5000	1.375	1.750	2.360	.044	2.937	8.5	325,590	2.65

BEARING NO.	DIMENSIONS IN MILLIMETERS							a° Misalign. Angle	Radial Static Limit Load Capacity Newtons	Approx. Brg. Wt. Grams
	B +.038 -.013	D +.000 -.018	H ±.13	W ±.13	O Flat Dia Ref.	M Chamfer Ref.	Ball Dia Ref.			
* COM-3KH	4.826	14.29	5.54	7.14	7.44	.38	10.31	11	21,701	6
* COM-4KH	6.350	16.67	6.35	8.71	9.25	.56	12.70	13.5	33,027	10
* COM-5KH	7.938	19.05	7.14	9.53	10.64	.81	14.27	12	43,206	14
COM-6KH	9.525	20.64	7.92	10.31	13.11	.81	16.66	10	56,042	17
* COM-7KH	11.113	23.02	8.71	11.10	13.46	.81	17.45	8	63,073	21
* COM-8KH	12.700	25.40	9.91	12.70	16.26	.81	20.65	9.5	88,402	29
* COM-9KH	14.288	27.78	11.10	14.27	18.03	.81	23.01	9.5	110,956	39
COM-10KH	15.875	30.16	12.70	15.88	19.81	.81	25.40	8.5	141,992	50
COM-12KH	19.050	36.51	15.06	19.05	23.37	1.12	30.15	9	212,988	93
* COM-14KH	22.225	39.69	17.86	22.23	24.89	1.12	33.32	9.5	279,963	119
* †COM-16KH	25.400	44.45	20.24	25.40	28.40	1.12	38.10	10	368,306	175
* †HCOM-16KH	25.400	50.80	19.84	25.40	34.54	.81	42.85	9	472,515	251
* †HCOM-19KH	30.163	60.33	23.80	30.15	40.89	.81	50.80	8.5	672,078	406
* †HCOM-20KH	31.750	60.33	23.80	30.15	40.89	.81	50.80	8.5	672,078	406
* †HCOM-24KH	38.100	69.85	27.79	34.93	47.24	.81	58.72	8.5	907,061	616
* †HCOM-28KH	44.450	79.38	31.75	39.67	53.59	1.12	66.68	8	1,176,747	884
* †HCOM-32KH	50.800	88.90	34.93	44.45	59.94	1.12	74.60	8.5	1,448,228	1,198

COM-E SERIES SPHERICAL BEARINGS

(PTFE Liners Available)¹

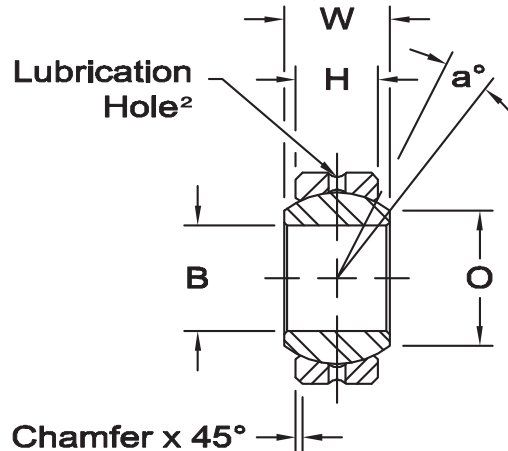
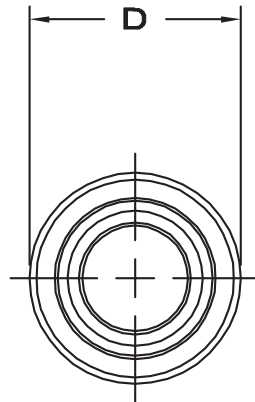

Race - 17 4 PH stainless steel (AMS 5643), heat treated.

Ball - 440 C stainless steel (AMS 5630), heat treated, chrome plated.

¹ PTFE Liners use suffix T Ex: COM 6ET

² PTFE Lined parts have no lubrication groove in race. Hole manufactures option.

BEARING NO.	DIMENSIONS IN INCHES							a° Misalign. Angle	Radial Static Limit Load Capacity Lbs.	Approx. Brg. Wt. Lbs.
	B +.0015 -.0005	D +.0000 -.0007	H ±.005	W ±.005	O Flat Dia Ref.	M Chamfer Ref.	Ball Dia Ref.			
COM-3E	.1900	.5625	.218	.281	.293	.015	.406	11	4,875	.01
COM-4E	.2500	.6562	.250	.343	.364	.022	.500	13.5	7,425	.02
COM-5E	.3125	.7500	.281	.375	.419	.032	.562	12	9,713	.03
COM-6E	.3750	.8125	.312	.406	.475	.032	.625	10	12,600	.04
COM-7E	.4375	.9062	.343	.437	.530	.032	.687	8	14,180	.05
COM-8E	.5000	1.0000	.390	.500	.600	.032	.781	9.5	19,875	.07
COM-9E	.5625	1.0937	.437	.562	.670	.032	.875	9.5	24,945	.09
COM-10E	.6250	1.1875	.500	.625	.739	.032	1.000	8.5	28,438	.11
COM-12E	.7500	1.4375	.593	.750	.920	.044	1.187	9	47,880	.20
COM-14E	.8750	1.5625	.703	.875	.980	.044	1.312	9.5	62,940	.26
COM-16E	1.0000	1.7500	.797	1.000	1.118	.044	1.500	10	82,800	.39

BEARING NO.	DIMENSIONS IN MILLIMETERS							a° Misalign. Angle	Radial Static Limit Load Capacity Newtons	Approx. Brg. Wt. Grams
	B +.038 -.013	D +.000 -.018	H ±.13	W ±.13	O Flat Dia Ref.	M Chamfer Ref.	Ball Dia Ref.			
COM-3E	4.826	14.29	5.54	7.14	7.44	.38	10.31	11	21,701	6
COM-4E	6.350	16.67	6.35	8.71	9.25	.56	12.70	13.5	33,027	10
COM-5E	7.938	19.05	7.14	9.53	10.64	.81	14.27	12	43,206	14
COM-6E	9.525	20.64	7.92	10.31	12.06	.81	15.88	10	56,042	17
COM-7E	11.113	23.02	8.71	11.10	13.46	.81	17.45	8	63,073	21
COM-8E	12.700	25.40	9.91	12.70	15.24	.81	19.84	9.5	88,402	29
COM-9E	14.288	27.78	11.10	14.27	17.02	.81	22.23	9.5	110,956	39
COM-10E	15.875	30.16	12.70	15.88	18.77	.81	25.40	8.5	126,492	50
COM-12E	19.050	36.51	15.06	19.05	23.37	1.12	30.15	9	212,988	93
COM-14E	22.225	39.69	17.86	22.23	24.89	1.12	33.32	9.5	279,963	119
COM-16E	25.400	44.45	20.24	25.40	28.40	1.12	38.10	10	368,306	175



LCOM SERIES LARGE SIZE SPHERICAL BEARINGS

(PTFE Liners Available)¹

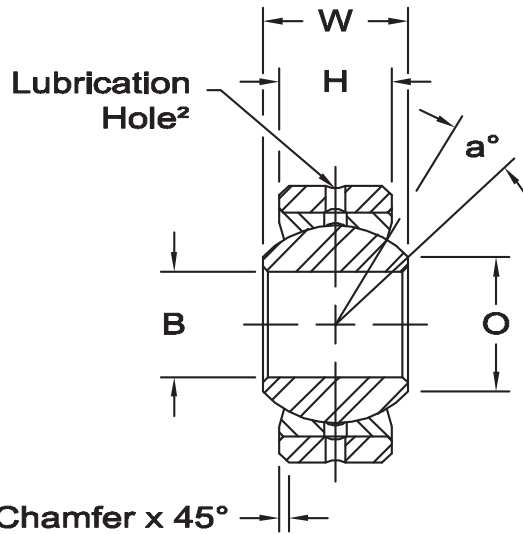
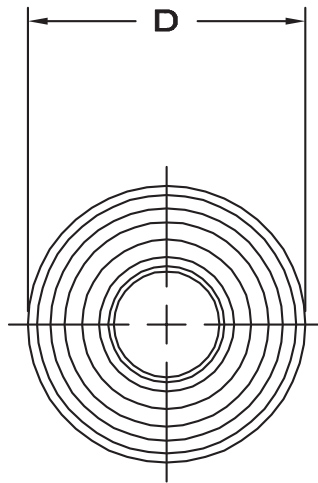

Outer Member - Carbon steel, protective coated for corrosion resistance.

Race - Carbon steel, exposed surfaces after installation protective coated for corrosion resistance.

Ball - Alloy steel, heat treated, hard chrome plated.

¹ PTFE Liners use suffix T Ex: LCOM 6T

² PTFE Lined parts have no lubrication groove in race.

BEARING NO.	DIMENSIONS IN INCHES							a° Misalign. Angle	Radial Static Limit Load Capacity Lbs.	Approx. Brg. Wt. Lbs.
	B +.0015 -.0005	D +.0000 -.0007	H ±.005	W ±.005	O Flat Dia Ref.	M Chamfer Ref.	Ball Dia Ref.			
LCOM-3	.1900	.6250	.187	.281	.293	.016	.406	16	3,037	.02
LCOM-4	.2500	.7500	.281	.375	.331	.016	.500	14	5,620	.04
LCOM-5	.3125	.8750	.313	.437	.448	.016	.625	14	7,825	.05
LCOM-6	.3750	1.0000	.375	.500	.516	.016	.719	12	10,785	.08
LCOM-7	.4375	1.1875	.437	.562	.586	.032	.812	11	14,194	.12
LCOM-8	.5000	1.3125	.531	.687	.637	.044	.937	12	19,902	.18
LCOM-10	.6250	1.5625	.687	.875	.802	.044	1.187	12	32,619	.33
LCOM-12	.7500	2.2500	.937	1.250	1.038	.044	1.625	15	60,905	.97
LCOM-12-1	.7500	1.8750	.687	.875	.978	.044	1.312	10	36,054	.52
LCOM-16	1.0000	2.3750	.875	1.125	1.345	.062	1.750	10	61,250	.94
LCOM-19	1.1875	2.6250	1.000	1.250	1.562	.085	2.000	8.5	80,000	1.27
LCOM-24	1.5000	3.2500	1.250	1.500	2.000	.085	2.500	7	125,000	2.38
LCOM-30	1.8750	4.0000	1.313	1.625	2.521	.125	3.000	7	157,560	3.75

BEARING NO.	DIMENSIONS IN MILLIMETERS							a° Misalign. Angle	Radial Static Limit Load Capacity Newtons	Approx. Brg. Wt. Grams
	B +.038 -.013	D +.000 -.018	H ±.13	W ±.13	O Flat Dia Ref.	M Chamfer Ref.	Ball Dia Ref.			
LCOM-3	4.826	15.88	4.75	7.14	7.44	.41	10.31	16	13,509	9
LCOM-4	6.350	19.05	7.14	9.53	8.41	.41	12.70	14	24,998	18
LCOM-5	7.938	22.23	7.95	11.10	11.38	.41	15.88	14	34,806	22
LCOM-6	9.525	25.40	9.53	12.70	13.11	.41	18.26	12	47,972	36
LCOM-7	11.113	30.16	11.10	14.27	14.88	.81	20.62	11	63,135	54
LCOM-8	12.700	33.34	13.49	17.45	16.18	1.12	23.80	12	88,524	82
LCOM-10	15.875	39.69	17.45	22.23	20.37	1.12	30.15	12	145,089	150
LCOM-12	19.050	57.15	23.80	31.75	26.37	1.12	41.28	15	270,905	440
LCOM-12-1	19.050	47.63	17.45	22.23	24.84	1.12	33.32	10	160,368	236
LCOM-16	25.400	60.33	22.23	28.56	34.16	1.57	44.45	10	272,440	426
LCOM-19	30.163	66.68	25.40	31.75	39.67	2.16	50.80	8.5	355,840	576
LCOM-24	38.100	82.55	31.75	38.10	50.80	2.16	63.50	7	556,000	1,080
LCOM-30	47.625	101.60	33.35	41.28	64.03	3.18	76.20	7	700,826	1,701

AIB, SIB, AND MIB SERIES

Spherical Bearings (PTFE Liners Available)¹

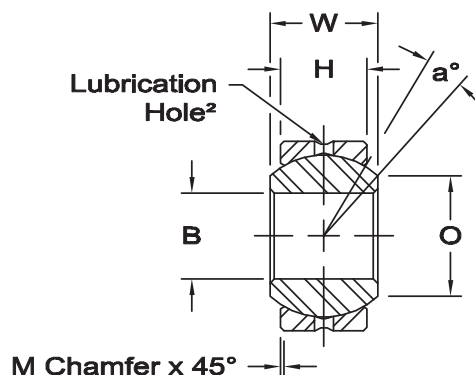
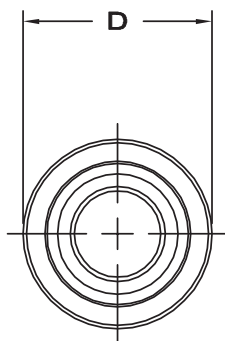

Series	Ball	Race
MIB	Alloy steel, heat treated, hard chrome plated.	Carbon steel, I.D. protective coated for corrosion resistance, oil coated.
AIB	Alloy steel, heat treated, hard chrome plated.	Alloy steel, heat treated, I.D. protective coated for corrosion resistance, oil coated.
SIB	Alloy steel, heat treated, hard chrome plated.	Stainless steel, heat treated, oil coated.

*Bore Tolerance on these items is as follows
INCH: +.0035, .0005; METRIC: +.089, .013

1 PTFE Liners use suffix T Ex: AIB 6T
2 PTFE Lined parts have no lubrication groove in race. Hole manufactures option.

BEARING NO.	DIMENSIONS IN INCHES								a° Misalign. Angle	Radial Static Limit Load Capacity Lbs.		Approx. Brg. Wt. Lbs.	
	B	D	H	W	O	M	Ball Dia. Ref.	MIB		AIB-SIB			
	+ .0015 - .0005	+ .0000 - .0007	± .005	+ .000 - .005	Flat Dia. Ref.	Chamfer Ref.							
AIB-3	SIB-3	MIB-3	.1900	.5312	.250	.312	.307	.020	.437	10.5	4,370	6,555	.02
AIB-4	SIB-4	MIB-4	.2500	.6094	.281	.375	.331	.020	.500	14.5	5,620	8,430	.02
AIB-5	SIB-5	MIB-5	.3125	.7500	.344	.437	.448	.020	.625	11.0	8,600	12,900	.04
AIB-6	SIB-6	MIB-6	.3750	.8437	.406	.500	.516	.020	.719	9.5	11,677	17,516	.06
AIB-7	SIB-7	MIB-7	.4375	1.0000	.437	.562	.587	.020	.812	11.0	14,194	21,291	.08
AIB-8	SIB-8	MIB-8	.5000	1.0937	.500	.625	.699	.020	.937	9.5	18,740	28,110	.11
AIB-10	SIB-10	MIB-10	.6250	1.3125	.562	.750	.839	.030	1.125	12.0	25,290	37,935	.17
AIB-12	SIB-12	MIB-12	.7500	1.5000	.687	.875	.978	.030	1.312	10.0	32,448	48,672	.25
AIB-14	SIB-14	MIB-14	.8750	1.6250	.750	.875	1.061	.035	1.375	6.0	39,653	58,653	.35
AIB-16*	SIB-16*	MIB-16*	1.0000	2.1250	1.000	1.375	1.275	.060	1.875	15.0	60,000	90,000	.79

BEARING NO.	DIMENSIONS IN MILLIMETERS								a° Misalign. Angle	Radial Static Limit Load Capacity Newtons		Approx. Brg. Wt. Grams	
	B	D	H	W	O	M	Ball Dia. Ref.	MIB		AIB-SIB			
	+ .038 - .013	+ .000 - .013	± .13	+ .00 - .13	Flat Dia. Ref.	Chamfer Ref.							
AIB-3	SIB-3	MIB-3	4.826	13.49	6.35	7.92	7.79	.50	11.10	10.5	19,438	29,157	7
AIB-4	SIB-4	MIB-4	6.350	15.47	7.13	9.52	8.40	.50	12.70	14.5	24,998	37,497	10
AIB-5	SIB-5	MIB-5	7.938	19.05	8.73	11.10	11.37	.50	15.87	11.0	38,253	57,379	18
AIB-6	SIB-6	MIB-6	9.525	21.43	10.31	12.70	13.10	.50	18.26	9.5	51,939	77,911	27
AIB-7	SIB-7	MIB-7	11.113	25.40	11.10	14.27	14.91	.50	20.62	11.0	63,135	94,702	36
AIB-8	SIB-8	MIB-8	12.700	27.78	12.70	15.87	17.75	.50	23.80	9.5	83,356	125,033	50
AIB-10	SIB-10	MIB-10	15.875	33.33	14.27	19.05	21.31	.76	28.57	12.0	112,490	168,735	75
AIB-12	SIB-12	MIB-12	19.050	38.10	17.45	22.23	24.84	.76	33.32	10.0	144,329	216,493	114
AIB-14	SIB-14	MIB-14	22.225	41.28	19.05	22.23	26.95	.89	34.93	6.0	176,637	260,889	159
AIB-16*	SIB-16*	MIB-16*	25.400	53.97	25.40	34.92	32.38	1.52	47.62	15.0	266,880	400,320	358



SPHERICAL PLAIN BEARINGS

Inch – Open & Sealed



GEZ..ES
OPEN

GEZ..ES-2RS
SEALED

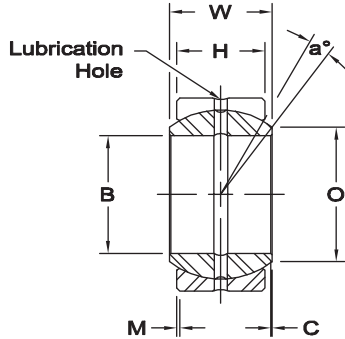
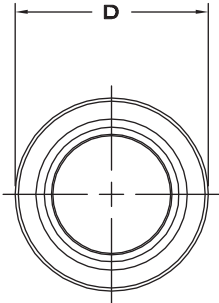

GEZ..ES
OPEN

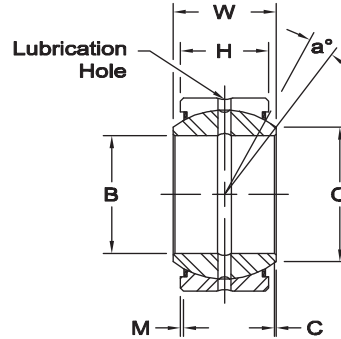

GEZ..ES-2RS
SEALED

Race - 52100 steel, heat treated, protective coated for corrosion resistance.

Ball - 52100 steel, heat treated, protective coated for corrosion resistance.

RADIAL STATIC LOAD CAPACITY

These loads are the maximum safe operating loads for stationary applications, and assumes a sufficiently rigid housing and shaft. The radial static load capacity provides a 1.5 factor of safety against static fracture.

LUBRICATION

Bearings should only be used as delivered for static applications. For dynamic applications, a lithium-based grease with EP and MOS_2 additives is especially suitable. Lubricants of this type are recommended for operating temperatures between $-40^{\circ}F$ and $+250^{\circ}F$ ($-40^{\circ}C$ and $+121^{\circ}C$). For operating temperatures outside of this range, consult lubricant manufacturer.

Bearings should be adequately lubricated before installation, and relubricated at suitable intervals based on application demands. Demand factors include load and load direction, misalignment angle and frequency, ambient temperature and contamination level.

BEARING NO.		DIMENSIONS IN INCHES										a° Misalign. Angle	Radial Static Limit Load Capacity Lbs.	Approx. Brg. Wt. Lbs.	
OPEN	SEALED	B Bore Dia.		D Race Dia.		W Ball Width		H Race Width		O Flat Dia.	C Ball Cmfr.				M Race Cmfr.
		Max.	Min.	Max.	Min.	Max.	Min.	Max.	Min.	Min.	Min.				Min.
GEZ008ES		.5000	.4995	.8750	.8745	.437	.432	.375	.365	.555	.006	.024	6	9,217	.05
GEZ010ES		.6250	.6245	1.0625	1.0620	.547	.542	.469	.459	.720	.006	.024	6	14,635	.08
GEZ012ES	GEZ012ES-2RS	.7500	.7495	1.2500	1.2495	.656	.651	.562	.552	.858	.012	.024	6	21,356	.12
GEZ014ES	GEZ014ES-2RS	.8750	.8745	1.4375	1.4370	.765	.760	.656	.646	1.000	.012	.024	6	28,550	.19
GEZ016ES	GEZ016ES-2RS	1.0000	.9995	1.6250	1.6245	.875	.870	.750	.740	1.087	.012	.024	6	37,317	.27
GEZ020ES	GEZ020ES-2RS	1.2500	1.2495	2.0000	1.9995	1.093	1.088	.937	.925	1.417	.024	.024	6	58,448	.51
GEZ022ES	GEZ022ES-2RS	1.3750	1.3745	2.1875	2.1870	1.187	1.182	1.031	1.019	1.515	.024	.039	6	69,688	.77
GEZ024ES	GEZ024ES-2RS	1.5000	1.4995	2.4375	2.4370	1.312	1.307	1.125	1.113	1.622	.024	.039	6	84,300	.93
GEZ028ES	GEZ028ES-2RS	1.7500	1.7495	2.8125	2.8120	1.531	1.526	1.312	1.300	1.996	.024	.039	6	114,648	1.41
GEZ032ES	GEZ032ES-2RS	2.0000	1.9995	3.1875	3.1869	1.750	1.745	1.500	1.484	2.280	.024	.039	6	150,616	2.06
GEZ036ES	GEZ036ES-2RS	2.2500	2.2494	3.5625	3.5619	1.969	1.963	1.687	1.671	2.555	.024	.039	6	191,080	2.93
GEZ040ES	GEZ040ES-2RS	2.5000	2.4994	3.9375	3.9369	2.187	2.181	1.875	1.859	2.886	.039	.039	6	238,288	4.08
GEZ044ES	GEZ044ES-2RS	2.7500	2.7494	4.3750	4.3744	2.406	2.400	2.062	2.046	3.114	.039	.039	6	281,000	5.34
GEZ048ES	GEZ048ES-2RS	3.0000	2.9994	4.7500	4.7493	2.625	2.619	2.250	2.230	3.417	.039	.039	6	337,200	6.83
GEZ052ES	GEZ052ES-2RS	3.2500	3.2492	5.1250	5.1243	2.844	2.836	2.437	2.417	3.720	.039	.039	6	395,648	8.42
GEZ056ES	GEZ056ES-2RS	3.5000	3.4992	5.5000	5.4993	3.062	3.054	2.625	2.605	4.000	.039	.039	6	458,595	10.56
GEZ060ES	GEZ060ES-2RS	3.7500	3.7492	5.8750	5.8743	3.281	3.273	2.812	2.792	4.280	.039	.039	6	530,528	12.74
GEZ064ES	GEZ064ES-2RS	4.0000	3.9992	6.2500	6.2490	3.500	3.492	3.000	2.980	4.559	.039	.039	6	595,720	15.41
GEZ068ES	GEZ068ES-2RS	4.2500	4.2492	6.6250	6.6240	3.719	3.711	3.187	3.167	4.835	.039	.039	6	674,400	18.54
GEZ072ES	GEZ072ES-2RS	4.5000	4.4992	7.0000	6.9990	3.937	3.929	3.375	3.355	5.142	.039	.039	6	764,320	21.58
GEZ076ES	GEZ076ES-2RS	4.7500	4.7490	7.3750	7.3738	4.156	4.148	3.562	3.542	5.417	.039	.039	6	843,000	25.35
GEZ080ES	GEZ080ES-2RS	5.0000	4.9990	7.7500	7.7488	4.375	4.365	3.750	3.730	5.720	.039	.039	6	932,920	29.76
GEZ096ES	GEZ096ES-2RS	6.0000	5.9990	8.7500	8.7488	4.750	4.740	4.125	4.105	6.622	.039	.039	5	1,168,960	38.58

SPHERICAL PLAIN BEARINGS

Metric – Open & Sealed



GE..ES
OPEN

GE..ES-2RS
SEALED



Race - 52100 steel, heat treated, protective coated for corrosion resistance.

Ball - 52100 steel, heat treated, protective coated for corrosion resistance.

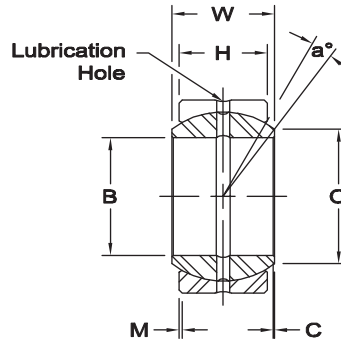
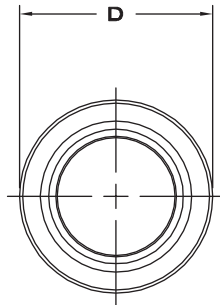

GE..ES
OPEN

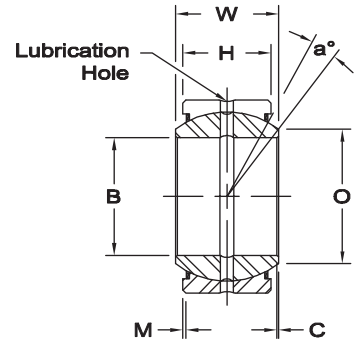

GE..ES-2RS
SEALED

RADIAL STATIC LOAD CAPACITY

These loads are the maximum safe operating loads for stationary applications, and assumes a sufficiently rigid housing and shaft. The radial static load capacity provides a 1.5 factor of safety against static fracture

LUBRICATION

Bearings should only be used as delivered for static applications. For dynamic applications, a lithium-based grease with EP and MOS_2 additives is especially suitable. Lubricants of this type are recommended for operating temperatures between $-40^\circ F$ and $+250^\circ F$ ($-40^\circ C$ and $+121^\circ C$). For operating temperatures outside of this range, consult lubricant manufacturer.

Bearings should be adequately lubricated before installation, and relubricated at suitable intervals based on application demands. Demand factors include load and load direction, misalignment angle and frequency, ambient temperature and contamination level.

* GE 12E only available without lube grooves and holes.

** Double fracture

BEARING NO.		DIMENSIONS IN MILLIMETERS											a° Misalign. Angle	Radial Static Limit Load Capacity kN	Approx. Brg. Wt. Grams		
OPEN	SEALED	B Bore Dia.		D Race Dia.		W Ball Width		H Race Width		O Flat Dia.	C Ball Cmfr.	M Race Cmfr.					
		Max.	Min.	Max.	Min.	Max.	Min.	Max.	Min.	Min.	Min.	Min.					
*	GE12E			12.000	11.992	22.000	21.991	10.00	9.88	7.00	6.76	15	0.3	0.3	10	53	15
	GE15ES	GE15ES-2RS		15.000	14.992	26.000	25.991	12.00	11.88	9.00	8.76	18	0.3	0.3	8	84	27
	GE17ES	GE17ES-2RS		17.000	16.992	30.000	29.991	14.00	13.88	10.00	9.76	20	0.3	0.3	10	106	41
	GE20ES	GE20ES-2RS		20.000	19.990	35.000	34.989	16.00	15.88	12.00	11.76	24	0.3	0.3	9	146	66
	GE25ES	GE25ES-2RS		25.000	24.990	42.000	41.989	20.00	19.88	16.00	15.76	29	0.6	0.6	7	240	119
	GE30ES	GE30ES-2RS		30.000	29.990	47.000	46.989	22.00	21.88	18.00	17.76	34	0.6	0.6	6	310	153
	GE35ES	GE35ES-2RS		35.000	34.988	55.000	54.987	25.00	24.88	20.00	19.70	39	0.6	1.0	6	399	233
	GE40ES	GE40ES-2RS		40.000	39.988	62.000	61.987	28.00	27.88	22.00	21.70	45	0.6	1.0	7	495	306
	GE45ES	GE45ES-2RS		45.000	44.988	68.000	67.987	32.00	31.88	25.00	24.70	50	0.6	1.0	7	637	427
	GE50ES	GE50ES-2RS		50.000	49.988	75.000	74.987	35.00	34.88	28.00	27.70	55	0.6	1.0	6	780	546
	GE60ES	GE60ES-2RS		60.000	59.985	90.000	89.985	44.00	43.85	36.00	35.60	66	1.0	1.0	6	1,220	1,040
	GE70ES	GE70ES-2RS		70.000	69.985	105.000	104.985	49.00	48.85	40.00	39.60	77	1.0	1.0	6	1,560	1,550
	GE80ES	GE80ES-2RS		80.000	79.985	120.000	119.985	55.00	54.85	45.00	44.60	88	1.0	1.0	6	2,000	2,310
	GE90ES	GE90ES-2RS		90.000	89.980	130.000	129.982	60.00	59.80	50.00	49.50	98	1.0	1.0	5	2,440	2,750
	GE100ES	GE100ES-2RS		100.000	99.980	150.000	149.982	70.00	69.80	55.00	54.50	109	1.0	1.0	7	3,030	4,450
	GE110ES	GE110ES-2RS		110.000	109.980	160.000	159.975	70.00	69.80	55.00	54.50	120	1.0	1.0	6	3,270	4,820
	GE120ES	GE120ES-2RS		120.000	119.980	180.000	179.975	85.00	84.80	70.00	69.50	135	1.0	1.0	6	4,750	8,050
	GE140ES	GE140ES-2RS		140.000	139.975	210.000	209.970	90.00	89.75	70.00	69.40	155	1.0	1.0	7	5,355	11,020
**	GE160ES	GE160ES-2RS		160.000	159.975	230.000	229.970	105.00	104.75	80.00	79.40	170	1.0	1.0	8	6,800	14,010



SPHERICAL PLAIN BEARINGS

Inch – Sealed – PTFE Lined

GEZ..ET-2RS SEALED

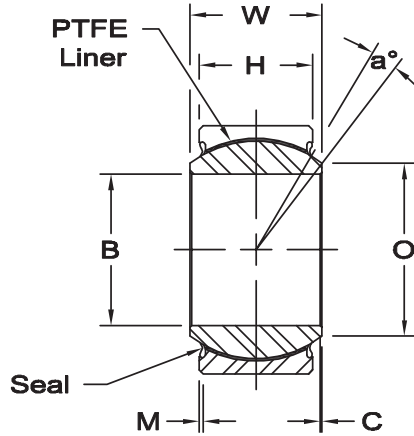
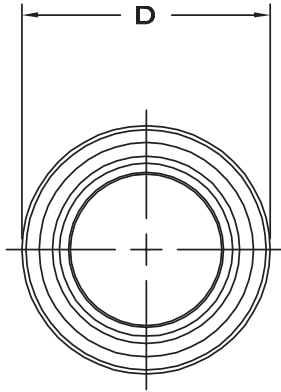

Race - 52100 steel, heat treated, single fracture, PTFE lined.

Ball - 52100 steel, heat treated, hard chrome plated.

RADIAL STATIC LOAD CAPACITY

These loads are the maximum safe operating loads for stationary applications, and assumes a sufficiently rigid housing and shaft. The radial static load capacity provides a 1.5 factor of safety against static fracture.

LUBRICATION

Self lubricating PTFE liner.

BEARING NO.	DIMENSIONS IN INCHES											a° Misalign. Angle	Radial Static Limit Load Capacity Lbs.	Approx. Brg. Wt. Lbs.
	B Bore Dia.		D Race Dia.		W Ball Width		H Race Width		O Flat Dia.	C Ball Cmfr.	M Race Cmfr.			
	Max.	Min.	Max.	Min.	Max.	Min.	Max.	Min.	Min.	Min.	Min.			
GEZ012ET-2RS	.7500	.7495	1.2500	1.2495	.656	.651	.562	.552	.858	.012	.024	6	20,682	.12
GEZ014ET-2RS	.8750	.8745	1.4375	1.4370	.765	.760	.656	.646	1.000	.012	.024	6	27,875	.19
GEZ016ET-2RS	1.0000	.9995	1.6250	1.6245	.875	.870	.750	.740	1.087	.012	.024	6	36,642	.27
GEZ020ET-2RS	1.2500	1.2495	2.0000	1.9995	1.093	1.088	.937	.925	1.417	.024	.024	6	58,898	.51
GEZ022ET-2RS	1.3750	1.3745	2.1875	2.1870	1.187	1.182	1.031	1.019	1.515	.024	.039	6	69,688	.77
GEZ024ET-2RS	1.5000	1.4995	2.4375	2.4370	1.312	1.307	1.125	1.113	1.622	.024	.039	6	82,277	.93
GEZ028ET-2RS	1.7500	1.7495	2.8125	2.8120	1.531	1.526	1.312	1.300	1.996	.024	.039	6	115,772	1.41
GEZ032ET-2RS	2.0000	1.9995	3.1875	3.1869	1.750	1.745	1.500	1.484	2.280	.024	.039	6	150,616	2.06
GEZ036ET-2RS	2.2500	2.2494	3.5625	3.5619	1.969	1.963	1.687	1.671	2.555	.024	.039	6	191,080	2.93
GEZ040ET-2RS	2.5000	2.4994	3.9375	3.9369	2.187	2.181	1.875	1.859	2.886	.039	.039	6	238,288	4.08
GEZ044ET-2RS	2.7500	2.7494	4.3750	4.3744	2.406	2.400	2.062	2.046	3.114	.039	.039	6	284,822	5.34
GEZ048ET-2RS	3.0000	2.9994	4.7500	4.7493	2.625	2.619	2.250	2.230	3.417	.039	.039	6	340,347	6.83
GEZ052ET-2RS	3.2500	3.2492	5.1250	5.1243	2.844	2.836	2.437	2.417	3.720	.039	.039	6	400,144	8.42
GEZ056ET-2RS	3.5000	3.4992	5.5000	5.4993	3.062	3.054	2.625	2.605	4.000	.039	.039	6	464,212	10.56
GEZ060ET-2RS	3.7500	3.7492	5.8750	5.8743	3.281	3.273	2.812	2.792	4.280	.039	.039	6	532,326	12.74
GEZ064ET-2RS	4.0000	3.9992	6.2500	6.2490	3.500	3.492	3.000	2.980	4.559	.039	.039	6	604,712	15.41
GEZ068ET-2RS	4.2500	4.2492	6.6250	6.6240	3.719	3.711	3.187	3.167	4.835	.039	.039	6	681,144	18.54
GEZ072ET-2RS	4.5000	4.4992	7.0000	6.9990	3.937	3.929	3.375	3.355	5.142	.039	.039	6	764,320	21.58
GEZ076ET-2RS	4.7500	4.7490	7.3750	7.3738	4.156	4.148	3.562	3.542	5.417	.039	.039	6	851,992	25.35
GEZ080ET-2RS	5.0000	4.9990	7.7500	7.7488	4.375	4.365	3.750	3.730	5.720	.039	.039	6	946,408	29.76
GEZ096ET-2RS	6.0000	5.9990	8.7500	8.7488	4.750	4.740	4.125	4.105	6.622	.039	.039	5	1,177,952	38.58

SPHERICAL PLAIN BEARINGS

Metric – Sealed – PTFE Lined



GE..ET-2RS SEALED

Race - 52100 steel, heat treated, single fracture, PTFE lined.

Ball - 52100 steel, heat treated, hard chrome plated.

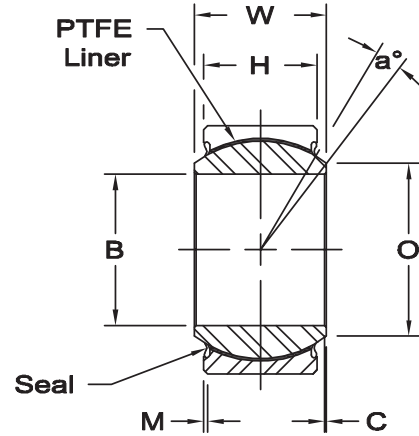
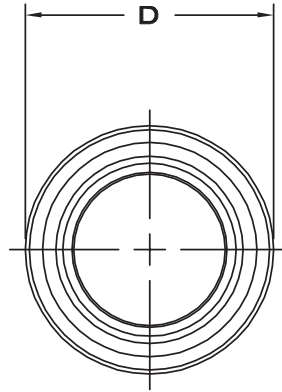

RADIAL STATIC LOAD CAPACITY

These loads are the maximum safe operating loads for stationary applications, and assumes a sufficiently rigid housing and shaft. The radial static load capacity provides a 1.5 factor of safety against static fracture.

LUBRICATION

Self lubricating PTFE liner.

* Parts 140mm and above have a double fracture race.

BEARING NO.	DIMENSIONS IN MILLIMETERS											a° Misalign. Angle	Radial Static Limit Load Capacity kN	Approx. Brg. Wt. Grams
	B Bore Dia.		D Race Dia.		W Ball Width		H Race Width		O Flat Dia.	C Ball Cmfr.	M Race Cmfr.			
	Max.	Min.	Max.	Min.	Max.	Min.	Max.	Min.	Min.	Min.	Min.			
GE15ET-2RS	15.000	14.992	26.000	25.991	12.00	11.88	9.00	8.76	18	0.3	0.3	8	47	27
GE17ET-2RS	17.000	16.992	30.000	29.991	14.00	13.88	10.00	9.76	20	0.3	0.3	10	60	41
GE20ET-2RS	20.000	19.990	35.000	34.989	16.00	15.88	12.00	11.76	24	0.3	0.3	9	83	66
GE25ET-2RS	25.000	24.990	42.000	41.989	20.00	19.88	16.00	15.76	29	0.6	0.6	7	137	119
GE30ET-2RS	30.000	29.990	47.000	46.989	22.00	21.88	18.00	17.76	34	0.6	0.6	6	176	153
GE35ET-2RS	35.000	34.988	55.000	54.987	25.00	24.88	20.00	19.70	39	0.6	1.0	6	224	233
GE40ET-2RS	40.000	39.988	62.000	61.987	28.00	27.88	22.00	21.70	45	0.6	1.0	7	280	306
GE45ET-2RS	45.000	44.988	68.000	67.987	32.00	31.88	25.00	24.70	50	0.6	1.0	7	360	427
GE50ET-2RS	50.000	49.988	75.000	74.987	35.00	34.88	28.00	27.70	55	0.6	1.0	6	440	546
GE60ET-2RS	60.000	59.985	90.000	89.985	44.00	43.85	36.00	35.60	66	1.0	1.0	6	695	1,040
GE70ET-2RS	70.000	69.985	105.000	104.985	49.00	48.85	40.00	39.60	77	1.0	1.0	6	880	1,550
GE80ET-2RS	80.000	79.985	120.000	119.985	55.00	54.85	45.00	44.60	88	1.0	1.0	6	1,140	2,310
GE90ET-2RS	90.000	89.980	130.000	129.982	60.00	59.80	50.00	49.50	98	1.0	1.0	5	1,370	2,750
GE100ET-2RS	100.000	99.980	150.000	149.982	70.00	69.80	55.00	54.50	109	1.0	1.0	7	1,730	4,450
GE110ET-2RS	110.000	109.980	160.000	159.975	70.00	69.80	55.00	54.50	120	1.0	1.0	6	1,860	4,820
GE120ET-2RS	120.000	119.980	180.000	179.975	85.00	84.80	70.00	69.50	135	1.0	1.0	6	2,700	8,050
GE140XT-2RS	140.000	139.975	210.000	209.970	90.00	89.75	70.00	69.40	155	1.0	1.0	7	3,000	11,020
GE160XT-2RS	160.000	159.975	230.000	229.970	105.00	104.75	80.00	79.40	170	1.0	1.0	8	3,800	14,010



SPHERICAL PLAIN BEARINGS

Heavy Duty Inch – Open & Sealed



GEGZ..ES
OPEN

GEGZ..ES-2RS
SEALED

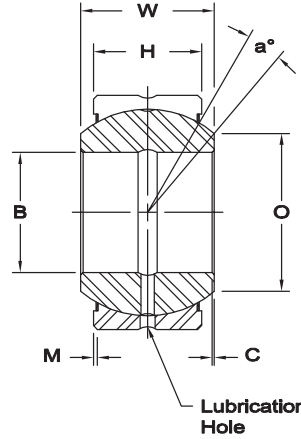
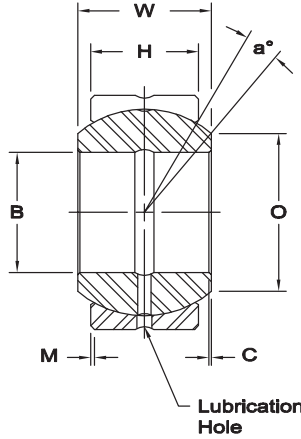
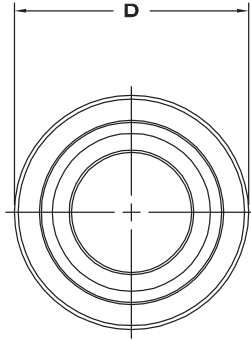

GEGZ..ES
OPEN

GEGZ..ES-2RS
SEALED

Race - 52100 steel, heat treated, protective coated for corrosion resistance.

Ball - 52100 steel, heat treated, protective coated for corrosion resistance.

RADIAL STATIC LOAD CAPACITY

These loads are the maximum safe operating loads for stationary applications, and assumes a sufficiently rigid housing and shaft. The radial static load capacity provides a 1.5 factor of safety against static fracture.

LUBRICATION

Bearings should only be used as delivered for static applications. For dynamic applications, a lithium-based grease with EP and MOS_2 additives is especially suitable. Lubricants of this type are recommended for operating temperatures between $-40^\circ F$ and $+250^\circ F$ ($-40^\circ C$ and $+121^\circ C$). For operating temperatures outside of this range, consult lubricant manufacturer.

Bearings should be adequately lubricated before installation, and relubricated at suitable intervals based on application demands. Demand factors include load and load direction, misalignment angle and frequency, ambient temperature and contamination level.

BEARING NO.		DIMENSIONS IN INCHES											a° Misalign. Angle	Radial Static Limit Load Capacity Lbs.	Approx. Brg. Wt. Lbs.
OPEN	SEALED	B Bore Dia.		D Race Dia.		W Ball Width		H Race Width		O Flat Dia.	C Ball Cmfr.	M Race Cmfr.			
		Max.	Min.	Max.	Min.	Max.	Min.	Max.	Min.	Min.	Min.				
GEGZ020ES	GEGZ020ES-2RS	1.2500	1.2495	2.4375	2.4370	1.390	1.385	1.125	1.113	1.645	.024	.040	15	84,300	1.00
GEGZ024ES	GEGZ024ES-2RS	1.5000	1.4995	2.8125	2.8120	1.580	1.575	1.312	1.300	1.958	.024	.040	14	114,648	1.60
GEGZ028ES	GEGZ028ES-2RS	1.7500	1.7495	3.1875	3.1869	1.820	1.815	1.500	1.484	2.224	.024	.040	14	150,616	2.51
GEGZ032ES	GEGZ032ES-2RS	2.0000	1.9994	3.5625	3.5619	2.070	2.064	1.687	1.671	2.477	.024	.040	14	191,080	3.70
GEGZ036ES	GEGZ036ES-2RS	2.2500	2.2494	3.9375	3.9369	2.318	2.312	1.875	1.859	2.783	.024	.040	14	238,288	4.43
GEGZ040ES	GEGZ040ES-2RS	2.5000	2.4994	4.3750	4.3744	2.545	2.539	2.062	2.046	3.004	.040	.040	14	281,000	6.50
GEGZ044ES	GEGZ044ES-2RS	2.7500	2.7494	4.7500	4.7493	2.790	2.784	2.250	2.230	3.286	.040	.040	14	337,200	8.00
GEGZ048ES	GEGZ048ES-2RS	3.0000	2.9994	5.1250	5.1243	3.022	3.016	2.437	2.417	3.580	.040	.040	14	395,648	9.61
GEGZ052ES	GEGZ052ES-2RS	3.2500	3.2492	5.5000	5.4993	3.265	3.257	2.625	2.605	3.838	.040	.040	14	458,592	11.71
GEGZ056ES	GEGZ056ES-2RS	3.5000	3.4992	5.8750	5.8743	3.560	3.552	2.812	2.792	4.052	.040	.040	14	530,528	15.01
GEGZ060ES	GEGZ060ES-2RS	3.7500	3.7492	6.2500	6.2490	3.738	3.730	3.000	2.980	4.367	.040	.040	14	595,720	19.51
GEGZ064ES	GEGZ064ES-2RS	4.0000	3.9992	7.0000	6.9990	4.225	4.217	3.375	3.355	4.908	.040	.040	10	764,320	22.49
GEGZ072ES	GEGZ072ES-2RS	4.5000	4.4992	7.7500	7.7488	4.690	4.682	3.750	3.726	5.470	.040	.040	10	932,920	29.98
GEGZ088ES	GEGZ088ES-2RS	5.5000	5.4990	8.7500	8.7488	4.950	4.940	4.125	4.101	6.475	.040	.040	9	1,168,960	44.97

SPHERICAL PLAIN BEARINGS

Heavy Duty Metric – Open & Sealed



GEG..ES
OPEN

GEG..ES-2RS
SEALED



Race - 52100 steel, heat treated, protective coated for corrosion resistance.

Ball - 52100 steel, heat treated, protective coated for corrosion resistance.

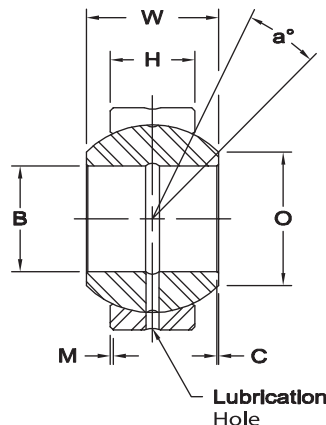
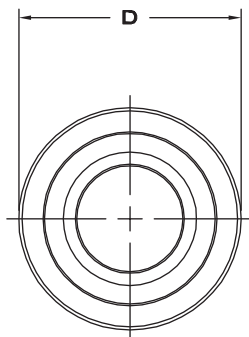

GEG..ES
OPEN

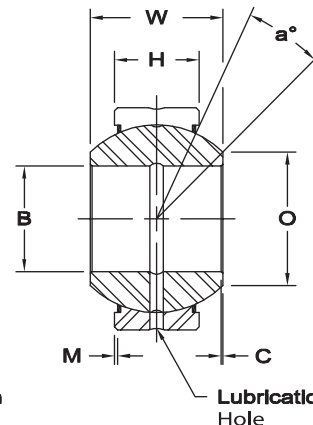

GEG..ES-2RS
SEALED

RADIAL STATIC LOAD CAPACITY

These loads are the maximum safe operating loads for stationary applications, and assumes a sufficiently rigid housing and shaft. The radial static load capacity provides a 1.5 factor of safety against static fracture

LUBRICATION

Bearings should only be used as delivered for static applications. For dynamic applications, a lithium-based grease with EP and MOS_2 additives is especially suitable. Lubricants of this type are recommended for operating temperatures between $-40^{\circ}F$ and $+250^{\circ}F$ ($-40^{\circ}C$ and $+121^{\circ}C$). For operating temperatures outside of this range, consult lubricant manufacturer.

Bearings should be adequately lubricated before installation, and relubricated at suitable intervals based on application demands. Demand factors include load and load direction, misalignment angle and frequency, ambient temperature and contamination level.

BEARING NO.		DIMENSIONS IN MILLIMETERS											a° Misalign. Angle	Radial Static Limit Load Capacity kN	Approx. Brg. Wt. Grams
OPEN	SEALED	B Bore Dia.		D Race Dia.		W Ball Width		H Race Width		O Flat Dia.	C Ball Cmfr.	M Race Cmfr.			
		Max.	Min.	Max.	Min.	Max.	Min.	Max.	Min.	Min.	Min.				
GEG12E		12.000	11.992	26.000	25.991	15.00	14.88	9.00	8.76	16.09	.3	.3	18	84	36
GEG15ES	GEG15ES-2RS	15.000	14.992	30.000	29.991	16.00	15.88	10.00	9.76	19.21	.3	.3	16	106	48
GEG17ES	GEG17ES-2RS	17.000	16.992	35.000	34.989	20.00	19.88	12.00	11.76	21.00	.3	.3	19	146	80
GEG20ES	GEG20ES-2RS	20.000	19.990	42.000	41.989	25.00	24.88	16.00	15.76	25.20	.3	.6	17	240	152
GEG25ES	GEG25ES-2RS	25.000	24.990	47.000	46.989	28.00	27.88	18.00	17.76	29.54	.6	.6	17	310	199
GEG30ES	GEG30ES-2RS	30.000	29.990	55.000	54.987	32.00	31.88	20.00	19.70	34.42	.6	1.0	17	399	296
GEG35ES	GEG35ES-2RS	35.000	34.988	62.000	61.987	35.00	34.88	22.00	21.70	39.80	.6	1.0	16	495	402
GEG40ES	GEG40ES-2RS	40.000	39.988	68.000	67.987	40.00	39.88	25.00	24.70	44.72	.6	1.0	17	637	535
GEG45ES	GEG45ES-2RS	45.000	44.988	75.000	74.987	43.00	42.88	28.00	27.70	50.07	.6	1.0	15	780	698
GEG50ES	GEG50ES-2RS	50.000	49.988	90.000	89.985	56.00	55.88	36.00	35.60	57.13	.6	1.0	17	1,220	1,420
GEG60ES	GEG60ES-2RS	60.000	59.985	105.000	104.985	63.00	62.85	40.00	39.60	67.04	1.0	1.0	17	1,560	2,090
GEG70ES	GEG70ES-2RS	70.000	69.985	120.000	119.985	70.00	69.85	45.00	44.60	78.26	1.0	1.0	16	2,000	3,010
GEG80ES	GEG80ES-2RS	80.000	79.985	130.000	129.982	75.00	74.85	50.00	49.50	87.18	1.0	1.0	14	2,440	3,610
GEG90ES	GEG90ES-2RS	90.000	89.980	150.000	149.982	85.00	84.80	55.00	54.50	98.36	1.0	1.0	15	3,030	5,500
GEG100ES	GEG100ES-2RS	100.000	99.980	160.000	159.975	85.00	84.80	55.00	54.50	111.24	1.0	1.0	14	3,270	6,040
GEG110ES	GEG110ES-2RS	110.000	109.980	180.000	179.975	100.00	99.80	70.00	69.50	124.90	1.0	1.0	12	4,750	9,740
GEG120ES	GEG120ES-2RS	120.000	119.980	210.000	209.970	115.00	114.80	70.00	69.40	138.47	1.0	1.0	16	5,350	15,100
GEG140ES	GEG140ES-2RS	140.000	139.975	230.000	229.970	130.00	129.75	80.00	79.40	151.99	1.0	1.0	16	6,800	18,900
GEG160ES	GEG160ES-2RS	160.000	159.975	260.000	259.965	135.00	134.75	80.00	79.30	180.00	1.1	1.1	16	7,650	24,800



SPHERICAL PLAIN BEARINGS

Extended Width Ball Inch – Open & Sealed



GEWZ..ES
OPEN



GEWZ..ES-2RS
SEALED

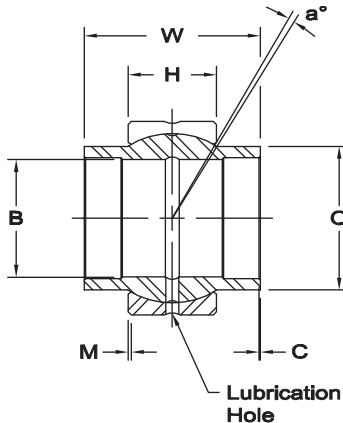
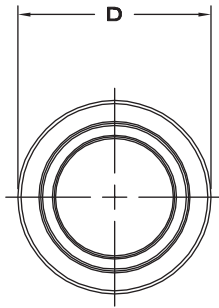

GEWZ..ES
OPEN

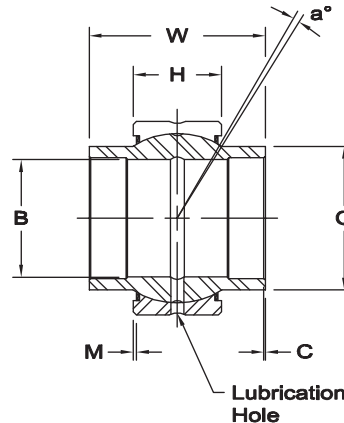

GEWZ..ES-2RS
SEALED

Race - 52100 steel, heat treated, protective coated for corrosion resistance.

Ball - 52100 steel, heat treated, protective coated for corrosion resistance.

RADIAL STATIC LOAD CAPACITY

These loads are the maximum safe operating loads for stationary applications, and assumes a sufficiently rigid housing and shaft. The radial static load capacity provides a 1.5 factor of safety against static fracture.

LUBRICATION

Bearings should only be used as delivered for static applications. For dynamic applications, a lithium-based grease with EP and MOS_2 additives is especially suitable. Lubricants of this type are recommended for operating temperatures between $-40^\circ F$ and $+250^\circ F$ ($-40^\circ C$ and $+121^\circ C$). For operating temperatures outside of this range, consult lubricant manufacturer.

Bearings should be adequately lubricated before installation, and relubricated at suitable intervals based on application demands. Demand factors include load and load direction, misalignment angle and frequency, ambient temperature and contamination level.

BEARING NO.		DIMENSIONS IN INCHES											a° Misalign. Angle	Radial Static Limit Load Capacity Lbs.	Approx. Brg. Wt. Lbs.
OPEN	SEALED	B Bore Dia.		D Race Dia.		W Ball Width		H Race Width		O Flat Dia.	C Ball Cmfr.	M Race Cmfr.			
		Max.	Min.	Max.	Min.	Max.	Min.	Max.	Min.	Min.	Min.				
GEWZ008ES	GEWZ008ES-2RS	.5000	.4995	.8750	.8745	.750	.745	.375	.366	.625	.006	.024	5	9,217	.05
GEWZ010ES	GEWZ010ES-2RS	.6250	.6245	1.0625	1.0620	.937	.932	.469	.460	.780	.006	.024	5	14,612	.08
GEWZ012ES	GEWZ012ES-2RS	.7500	.7495	1.2500	1.2495	1.125	1.120	.562	.553	.920	.012	.024	5	21,356	.14
GEWZ014ES	GEWZ014ES-2RS	.8750	.8745	1.4375	1.4370	1.312	1.307	.656	.647	1.070	.012	.024	5	28,550	.22
GEWZ016ES	GEWZ016ES-2RS	1.0000	.9995	1.6250	1.6245	1.500	1.495	.750	.741	1.220	.012	.024	5	37,317	.31
GEWZ020ES	GEWZ020ES-2RS	1.2500	1.2495	2.0000	1.9995	1.875	1.870	.937	.925	1.525	.024	.024	5	58,448	.60
GEWZ022ES	GEWZ022ES-2RS	1.3750	1.3745	2.1875	2.1870	2.062	2.057	1.031	1.019	1.670	.024	.040	5	69,688	.82
GEWZ024ES	GEWZ024ES-2RS	1.5000	1.4995	2.4375	2.4370	2.250	2.245	1.125	1.113	1.850	.024	.040	5	84,300	1.09
GEWZ028ES	GEWZ028ES-2RS	1.7500	1.7495	2.8125	2.8120	2.625	2.620	1.312	1.300	2.165	.024	.040	5	114,648	1.68
GEWZ032ES	GEWZ032ES-2RS	2.0000	1.9994	3.1875	3.1869	3.000	2.994	1.500	1.484	2.460	.024	.040	5	150,616	2.45
GEWZ036ES	GEWZ036ES-2RS	2.2500	2.2494	3.5625	3.5619	3.375	3.369	1.687	1.671	2.760	.024	.040	5	191,080	3.46
GEWZ040ES	GEWZ040ES-2RS	2.5000	2.4994	3.9375	3.9369	3.750	3.744	1.875	1.859	3.060	.040	.040	5	238,288	4.74
GEWZ044ES	GEWZ044ES-2RS	2.7500	2.7494	4.3750	4.3744	4.125	4.119	2.062	2.046	3.380	.040	.040	5	281,000	6.39
GEWZ048ES	GEWZ048ES-2RS	3.0000	2.9994	4.7500	4.7493	4.500	4.494	2.250	2.230	3.675	.040	.040	5	337,200	7.91
GEWZ052ES	GEWZ052ES-2RS	3.2500	3.2492	5.1250	5.1243	4.875	4.867	2.437	2.417	3.985	.040	.040	5	395,648	10.34
GEWZ056ES	GEWZ056ES-2RS	3.5000	3.4992	5.5000	5.4993	5.250	5.242	2.625	2.605	4.300	.040	.040	5	458,592	12.92
GEWZ060ES	GEWZ060ES-2RS	3.7500	3.7492	5.8750	5.8743	5.625	5.617	2.812	2.792	4.590	.040	.040	5	530,528	15.67
GEWZ064ES	GEWZ064ES-2RS	4.0000	3.9992	6.2500	6.2490	6.000	5.992	3.000	2.980	4.905	.040	.040	5	595,720	18.87
GEWZ072ES	GEWZ072ES-2RS	4.5000	4.4992	7.0000	6.9990	6.750	6.742	3.375	3.355	5.525	.040	.040	5	764,320	26.98
GEWZ080ES	GEWZ080ES-2RS	5.0000	4.9990	7.7500	7.7488	7.500	7.490	3.750	3.726	6.130	.040	.040	5	932,920	36.66
GEWZ096ES	GEWZ096ES-2RS	6.0000	5.9990	8.7500	8.7488	8.250	8.240	4.125	4.101	7.020	.040	.040	5	1,168,960	45.64

SPHERICAL PLAIN BEARINGS

Extended Width Ball Metric – Open & Sealed



GEEW..ES
OPEN

GEEW..ES-2RS
SEALED



Race - 52100 steel, heat treated, protective coated for corrosion resistance.

Ball - 52100 steel, heat treated, protective coated for corrosion resistance.

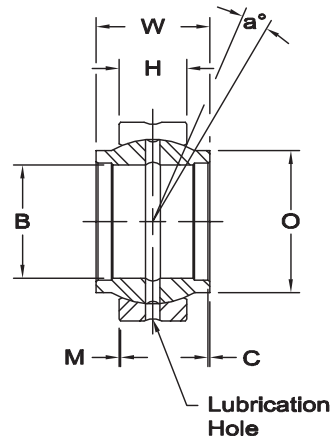
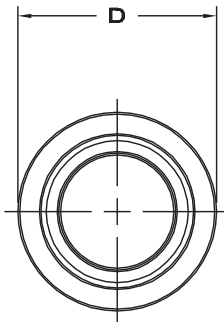

RADIAL STATIC LOAD CAPACITY

These loads are the maximum safe operating loads for stationary applications, and assumes a sufficiently rigid housing and shaft. The radial static load capacity provides a 1.5 factor of safety against static fracture

LUBRICATION

Bearings should only be used as delivered for static applications. For dynamic applications, a lithium-based grease with EP and MOS_2 additives is especially suitable. Lubricants of this type are recommended for operating temperatures between $-40^\circ F$ and $+250^\circ F$ ($-40^\circ C$ and $+121^\circ C$). For operating temperatures outside of this range, consult lubricant manufacturer.

Bearings should be adequately lubricated before installation, and relubricated at suitable intervals based on application demands. Demand factors include load and load direction, misalignment angle and frequency, ambient temperature and contamination level.

BEARING NO.		DIMENSIONS IN MILLIMETERS										a° Misalign. Angle	Radial Static Limit Load Capacity kN	Approx. Brg. Wt. Grams	
OPEN	SEALED	B Bore Dia.		D Race Dia.		W Ball Width		H Race Width		O Flat Dia.	C Ball Cmfr.				M Race Cmfr.
		Max.	Min.	Max.	Min.	Max.	Min.	Max.	Min.	Min.	Min.				
GEEW12ES		12.018	12.000	22.000	21.991	12.00	11.82	7.00	6.76	15.50	.30	.30	4	53	17
GEEW15ES	GEEW15ES-2RS	15.018	15.000	26.000	25.991	15.00	14.82	9.00	8.76	18.50	.30	.30	5	84	28
GEEW16ES	GEEW16ES-2RS	16.018	16.000	28.000	27.991	16.00	15.82	9.00	8.76	20.00	.30	.30	4	85	34
GEEW17ES	GEEW17ES-2RS	17.018	17.000	30.000	29.991	17.00	16.82	10.00	9.76	21.00	.30	.30	7	106	43
GEEW20ES	GEEW20ES-2RS	20.021	20.000	35.000	34.989	20.00	19.79	12.00	11.76	25.00	.30	.30	4	146	69
GEEW25ES	GEEW25ES-2RS	25.021	25.000	42.000	41.989	25.00	24.79	16.00	15.76	30.50	.60	.60	4	240	124
GEEW30ES	GEEW30ES-2RS	30.021	30.000	47.000	46.989	30.00	29.79	18.00	17.76	34.00	.60	.60	4	310	159
GEEW32ES	GEEW32ES-2RS	32.025	32.000	52.000	51.987	32.00	31.75	18.00	17.70	37.00	.60	1.00	4	328	207
GEEW35ES	GEEW35ES-2RS	35.025	35.000	55.000	54.987	35.00	34.75	20.00	19.70	40.00	.60	1.00	4	399	248
GEEW40ES	GEEW40ES-2RS	40.025	40.000	62.000	61.987	40.00	39.75	22.00	21.70	46.00	.60	1.00	4	495	349
GEEW45ES	GEEW45ES-2RS	45.025	45.000	68.000	67.987	45.00	44.75	25.00	24.70	52.00	.60	1.00	4	637	468
GEEW50ES	GEEW50ES-2RS	50.025	50.000	75.000	74.987	50.00	49.75	28.00	27.70	57.00	.60	1.00	4	780	620
GEEW60ES	GEEW60ES-2RS	60.030	60.000	90.000	89.985	60.00	59.70	36.00	35.60	68.00	1.00	1.00	4	1,220	1,110
GEEW63ES	GEEW63ES-2RS	63.030	63.000	95.000	94.985	63.00	62.70	36.00	35.60	71.50	1.00	1.00	4	1,260	1,270
GEEW70ES	GEEW70ES-2RS	70.030	70.000	105.000	104.985	70.00	69.70	40.00	39.60	78.00	1.00	1.00	4	1,560	1,690
GEEW80ES	GEEW80ES-2RS	80.030	80.000	120.000	119.985	80.00	79.70	45.00	44.60	91.00	1.00	1.00	4	2,000	2,550
GEEW90ES	GEEW90ES-2RS	90.035	90.000	130.000	129.982	90.00	89.65	50.00	49.50	99.00	1.00	1.00	4	2,440	3,040
GEEW100ES	GEEW100ES-2RS	100.035	100.000	150.000	149.982	100.00	99.65	55.00	54.50	113.00	1.00	1.00	4	3,030	4,870
GEEW110ES	GEEW110ES-2RS	110.035	110.000	160.000	159.975	110.00	109.65	55.00	54.50	124.00	1.00	1.00	4	3,270	5,530
GEEW125ES	GEEW125ES-2RS	125.040	125.000	180.000	179.975	125.00	124.60	70.00	69.50	138.00	1.00	1.00	4	4,750	8,190
GEEW160ES	GEEW160ES-2RS	160.040	160.000	230.000	229.970	160.00	159.60	80.00	79.40	177.00	1.00	1.00	4	6,800	15,800
GEEW200ES	GEEW200ES-2RS	200.046	200.000	290.000	289.965	200.00	199.54	100.00	99.30	221.00	1.10	1.10	4	10,600	31,700
GEEW250ES	GEEW250ES-2RS	250.046	250.000	400.000	399.960	250.00	249.54	120.00	119.20	317.00	1.10	1.10	4	17,800	101,000
GEEW320ES	GEEW320ES-2RS	320.057	320.000	520.000	519.950	320.00	319.43	160.00	159.00	405.00	1.10	1.10	4	30,500	225,000



ANGULAR CONTACT SPHERICAL PLAIN BEARINGS

Inch

GACZ..S OPEN

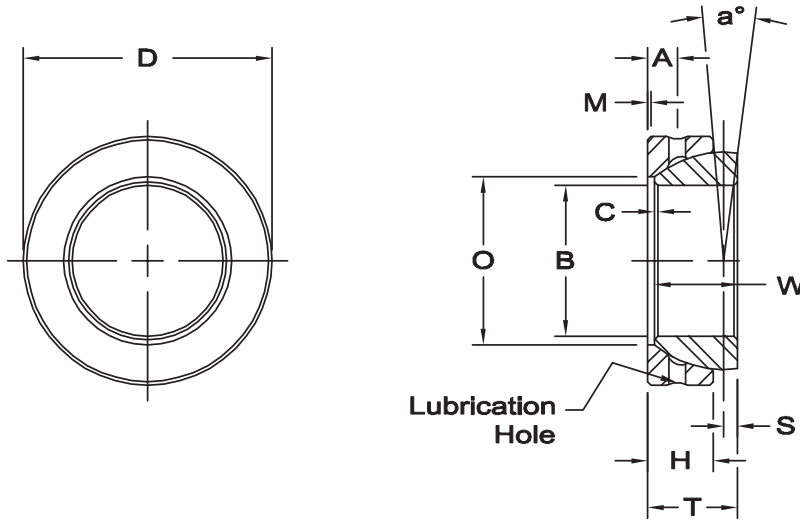

Race - 52100 steel, heat treated, protective coated for corrosion resistance

Ball - 52100 steel, heat treated, protective coated for corrosion resistance.

LUBRICATION

Bearings should only be used as delivered for static applications. For dynamic applications, a lithium-based grease with EP and MOS_2 additives is especially suitable. Lubricants of this type are recommended for operating temperatures between $-40^\circ F$ and $+250^\circ F$ ($-40^\circ C$ and $+121^\circ C$). For operating temperatures outside of this range, consult lubricant manufacturer.

Bearings should be adequately lubricated before installation, and relubricated at suitable intervals based on application demands. Demand factors include load and load direction, misalignment angle and frequency, ambient temperature and contamination level.

BEARING NO.	DIMENSIONS IN INCHES													a° Misalign. Angle	Static Thrust Load Capacity Lbs.	Approx. Brg. Wt. Lbs.
	B Bore Dia.		D Race Dia.		W Ball Width		H Race Width		T Ref.	Spherical Dia.	S Loc. Sphere Dia.	A End to Hole	C.M Ball, Race Cnfr.			
	Max.	Min.	Max.	Min.	Max.	Min.	Max.	Min.		Ref.		Ref.	Min.			
GACZ008S	.5000	.4995	.8750	.8745	.270	.261	.190	.181	.300	.719	.051	.094	.020	7	4,046	.029
GACZ010S	.6250	.6245	1.0625	1.0619	.340	.331	.250	.241	.370	.899	.058	.109	.030	6	6,969	.055
GACZ012S	.7500	.7495	1.2500	1.2494	.410	.401	.310	.301	.440	1.080	.070	.125	.040	6	10,566	.084
GACZ014S	.8750	.8745	1.4375	1.4369	.480	.471	.380	.371	.520	1.258	.080	.172	.080	5.5	14,837	.108
GACZ016S	1.0000	.9995	1.6250	1.6244	.550	.541	.440	.431	.600	1.437	.100	.203	.080	6	19,558	.187
GACZ020S	1.2500	1.2495	2.0000	1.9994	.700	.691	.550	.538	.740	1.795	.132	.234	.080	6	31,922	.351
GACZ022S	1.3750	1.3745	2.1875	2.1869	.770	.761	.600	.588	.840	1.937	.145	.281	.100	4	35,743	.470
GACZ024S	1.5000	1.4995	2.4375	2.4369	.840	.831	.660	.648	.910	2.155	.155	.312	.100	5.5	44,286	.664
GACZ028S	1.7500	1.7495	2.8125	2.8119	.980	.971	.790	.778	1.070	2.515	.186	.328	.100	6	61,370	1.010
GACZ032S	2.0000	1.9994	3.1875	3.1868	1.130	1.118	.920	.908	1.230	2.875	.217	.375	.140	5.5	82,052	1.479
GACZ036S	2.2500	2.2494	3.5625	3.5618	1.270	1.258	1.050	1.034	1.390	3.235	.243	.453	.140	5.5	104,757	2.090
GACZ040S	2.5000	2.4994	3.9375	3.9368	1.420	1.408	1.180	1.164	1.540	3.590	.267	.500	.140	5	132,407	2.491
GACZ044S	2.7500	2.7494	4.3750	4.3773	1.560	1.548	1.275	1.259	1.700	3.950	.294	.515	.180	5	156,011	3.858
GACZ048S	3.0000	2.9994	4.7500	4.7492	1.710	1.698	1.405	1.389	1.860	4.312	.322	.578	.180	5	188,382	5.026
GACZ052S	3.2500	3.2492	5.1250	5.1242	1.860	1.844	1.545	1.529	2.030	4.675	.356	.656	.180	5	223,676	6.371
GACZ056S	3.5000	3.4992	5.5000	5.4992	2.000	1.984	1.675	1.659	2.180	5.040	.374	.703	.180	5	262,342	7.870
GACZ060S	3.7500	3.7492	5.8750	5.8742	2.150	2.134	1.805	1.789	2.340	5.390	.398	.765	.180	4.5	303,030	9.590
GACZ064S	4.0000	3.9992	6.2500	6.2490	2.300	2.284	1.935	1.919	2.500	5.750	.409	.781	.180	4.5	347,316	11.596
GACZ072S	4.5000	4.4992	7.0000	6.9990	2.590	2.574	2.195	2.179	2.800	6.475	.488	.875	.180	4.5	447,352	17.108
GACZ080S	5.0000	4.9990	7.7500	7.7488	2.880	2.860	2.455	2.435	3.130	7.190	.547	1.000	.180	4.5	551,884	24.405
GACZ096S	6.0000	5.9990	8.7500	8.7488	3.100	3.080	2.615	2.595	3.375	8.156	.634	1.370	.180	4.5	664,284	38.294

ANGULAR CONTACT SPHERICAL PLAIN BEARINGS

Metric



**GAC..S
OPEN**

Race - 52100 steel, heat treated, protective coated for corrosion resistance.

Ball - 52100 steel, heat treated, protective coated for corrosion resistance.

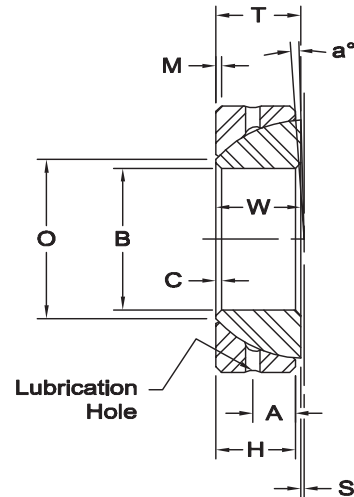
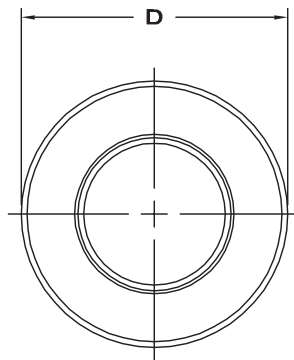

LUBRICATION

Bearings should only be used as delivered for static applications. For dynamic applications, a lithium-based grease with EP and MOS_2 additives is especially suitable. Lubricants of this type are recommended for operating temperatures between -40°F and $+250^\circ\text{F}$ (-40°C and $+121^\circ\text{C}$). For operating temperatures outside of this range, consult lubricant manufacturer.

Bearings should be adequately lubricated before installation, and relubricated at suitable intervals based on application demands. Demand factors include load and load direction, misalignment angle and frequency, ambient temperature and contamination level.

BEARING NO.	DIMENSIONS IN MILLIMETERS													a° Misalign. Angle	Static Thrust Load Capacity kN	Approx. Brg. Wt. Grams
	B Bore Dia.		D Race Dia.		W Ball Width		H Race Width		T Ref.	Spherical Dia. Ref.	S Loc. Sphere Dia.	A End to Hole Ref.	C,M Ball, Race Cmfr. Min.			
	Max.	Min.	Max.	Min.	Max.	Min.	Max.	Min.								
GAC25S	25.000	24.988	47.000	46.986	15.00	14.76	14.00	13.76	15.00	42.00	.60	7.50	1.0	2.5	250	148
GAC28S	28.000	27.988	52.000	51.984	15.00	14.76	15.00	14.70	16.00	47.00	1.00	8.00	1.0	2.0	300	186
GAC30S	30.000	29.988	55.000	54.984	17.00	16.76	15.00	14.70	17.00	49.50	1.30	8.50	1.0	4.5	315	208
GAC32S	32.000	31.988	58.000	57.984	17.00	16.76	16.00	15.70	17.00	52.00	2.00	8.50	1.0	2.0	354	241
GAC35S	35.000	34.988	62.000	61.984	18.00	17.76	16.00	15.70	18.00	55.50	2.10	9.00	1.0	4.0	390	268
GAC40S	40.000	39.988	68.000	67.984	19.00	18.76	17.00	16.70	19.00	62.00	2.80	9.50	1.0	3.5	463	327
GAC45S	45.000	44.988	75.000	74.984	20.00	19.76	18.00	17.70	20.00	68.50	3.50	10.00	1.0	3.0	540	416
GAC50S	50.000	49.988	80.000	79.984	20.00	19.76	19.00	18.70	20.00	74.00	4.30	10.00	1.0	1.5	618	455
GAC55S	55.000	54.985	90.000	89.982	23.00	22.76	20.00	19.60	23.00	82.00	5.00	11.50	1.1	4.0	721	645
GAC60S	60.000	59.985	95.000	94.982	23.00	22.70	21.00	20.60	23.00	88.50	5.70	11.50	1.1	2.5	817	714
GAC65S	65.000	64.985	100.000	99.982	23.00	22.70	22.00	21.60	23.00	93.50	6.50	11.50	1.1	1.0	905	759
GAC70S	70.000	69.985	110.000	109.982	25.00	24.70	23.00	22.60	25.00	102.00	7.20	12.50	1.1	2.0	1,030	1,040
GAC75S	75.000	74.985	115.000	114.982	25.00	24.70	24.00	23.60	25.00	107.00	7.90	12.50	1.1	1.0	1,129	1,120
GAC80S	80.000	79.985	125.000	124.980	29.00	28.70	25.50	25.00	29.00	115.00	8.60	14.50	1.1	3.5	1,290	1,540
GAC85S	85.000	84.980	130.000	129.980	29.00	28.60	26.50	26.00	29.00	122.00	9.40	14.50	1.1	2.0	1,422	1,610
GAC90S	90.000	89.980	140.000	139.980	32.00	31.60	28.00	27.50	32.00	128.50	10.10	16.00	1.5	3.5	1,580	2,090
GAC95S	95.000	94.980	145.000	144.980	32.00	31.60	29.50	29.00	32.00	135.00	10.80	16.00	1.5	2.0	1,750	2,220
GAC100S	100.000	99.980	150.000	149.980	32.00	31.60	31.00	30.50	32.00	141.00	11.60	16.00	1.5	.5	1,923	2,340
GAC105S	105.000	104.980	160.000	159.975	35.00	34.60	32.50	32.00	35.00	148.00	12.30	17.50	2.0	2.0	2,116	2,930
GAC110S	110.000	109.980	170.000	169.975	38.00	37.60	34.00	33.50	38.00	155.00	13.00	19.00	2.0	3.0	2,318	3,680
GAC120S	120.000	119.980	180.000	179.975	38.00	37.60	37.00	36.50	38.00	168.00	14.50	19.00	2.0	.5	2,735	3,970
GAC130S	130.000	129.975	200.000	199.970	45.00	44.50	43.00	42.40	45.00	188.00	18.00	19.00	2.5	1.0	3,550	5,920
GAC140S	140.000	139.975	210.000	209.970	45.00	44.50	43.00	42.40	45.00	198.00	19.00	19.00	2.5	1.0	3,740	6,330
GAC150S	150.000	149.975	225.000	224.970	48.00	47.50	46.00	45.40	48.00	211.00	20.00	20.50	3.0	1.0	4,270	8,010
GAC160S	160.000	159.975	240.000	239.970	51.00	50.50	49.00	48.40	51.00	225.00	20.00	22.00	3.0	1.0	4,850	9,790
GAC170S	170.000	169.975	260.000	259.965	57.00	56.50	55.00	54.30	57.00	246.00	21.00	27.00	3.0	1.0	5,950	12,300
GAC180S	180.000	179.975	280.000	279.965	64.00	63.50	61.00	60.30	64.00	260.00	21.00	28.00	3.0	1.0	6,970	17,400
GAC190S	190.000	189.970	290.000	289.965	64.00	63.40	62.00	61.30	64.00	275.00	26.00	30.00	3.0	0.5	7,500	18,200
GAC200S	200.000	199.970	310.000	309.965	70.00	69.40	66.00	65.30	70.00	290.00	26.00	30.00	3.0	1.5	8,420	23,800



ANGULAR CONTACT SPHERICAL PLAIN BEARINGS

Metric – PTFE Lined

GAC..T

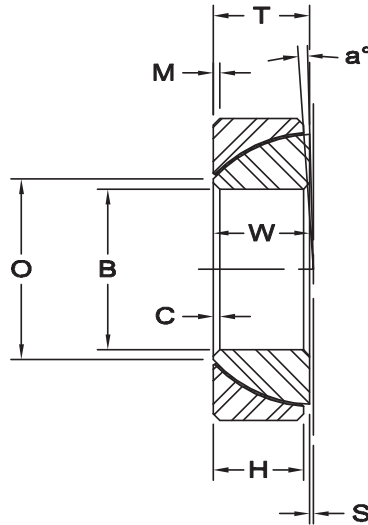
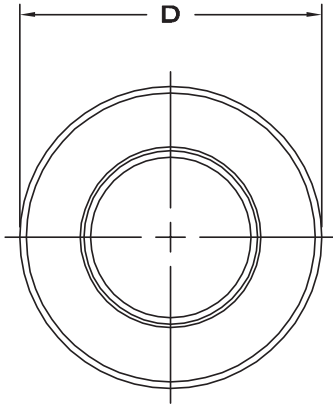

Race - 52100 steel, heat treated, PTFE lined.

Ball - 52100 steel, heat treated, hard chrome plated.

LUBRICATION

Self lubricating PTFE liner.

BEARING NO.	DIMENSIONS IN MILLIMETERS												a° Misalign. Angle	Static Thrust Load Capacity kN	Approx. Brg. Wt. Grams
	B Bore Dia.		D Race Dia.		W Ball Width		H Race Width		T Ref.	Spherical Dia.	S Loc. Sphere Dia.	C,M Ball, Race Cmfr.			
	Max.	Min.	Max.	Min.	Max.	Min.	Max.	Min.	Ref.	Ref.	Min.	Min.			
GAC25T	25.000	24.988	47.000	46.986	15.00	14.76	14.00	13.76	15.00	42.00	.60	1.0	2.5	225	148
GAC28T	28.000	27.988	52.000	51.984	15.00	14.76	15.00	14.70	16.00	47.00	1.00	1.0	2	270	186
GAC30T	30.000	29.988	55.000	54.984	17.00	16.76	15.00	14.70	17.00	49.50	1.30	1.0	4.5	285	208
GAC32T	32.000	31.988	58.000	57.984	17.00	16.76	16.00	15.70	17.00	52.00	2.00	1.0	2	320	241
GAC35T	35.000	34.988	62.000	61.984	18.00	17.76	16.00	15.70	18.00	55.50	2.10	1.0	4	340	268
GAC40T	40.000	39.988	68.000	67.984	19.00	18.76	17.00	16.70	19.00	62.00	2.80	1.0	3.5	400	327
GAC45T	45.000	44.988	75.000	74.984	20.00	19.76	18.00	17.70	20.00	68.50	3.50	1.0	3	470	416
GAC50T	50.000	49.988	80.000	79.984	20.00	19.76	19.00	18.70	20.00	74.00	4.30	1.0	1.5	540	455
GAC55T	55.000	54.985	90.000	89.982	23.00	22.70	20.00	19.60	23.00	82.00	5.00	1.1	4	630	645
GAC60T	60.000	59.985	95.000	94.982	23.00	22.70	21.00	20.60	23.00	88.50	5.70	1.1	2.5	710	714
GAC65T	65.000	64.985	100.000	99.982	23.00	22.70	22.00	21.60	23.00	93.50	6.50	1.1	1	790	759
GAC70T	70.000	69.985	110.000	109.982	25.00	24.70	23.00	22.60	25.00	102.00	7.20	1.1	2	900	1,040
GAC75T	75.000	74.985	115.000	114.982	25.00	24.70	24.00	23.60	25.00	107.00	7.90	1.1	1	980	1,120
GAC80T	80.000	79.985	125.000	124.980	29.00	28.70	25.50	25.00	29.00	115.00	8.60	1.1	3.5	1,120	1,540
GAC85T	85.000	84.980	130.000	129.980	29.00	28.60	26.50	26.00	29.00	122.00	9.40	1.1	2	1,240	1,610
GAC90T	90.000	89.980	140.000	139.980	32.00	31.60	28.00	27.50	32.00	128.50	10.10	1.5	3.5	1,380	2,090
GAC95T	95.000	94.980	145.000	144.980	32.00	31.60	29.50	29.00	32.00	135.00	10.80	1.5	2	1,530	2,220
GAC100T	100.000	99.980	150.000	149.980	32.00	31.60	31.00	30.50	32.00	141.00	11.60	1.5	.5	1,680	2,340
GAC105T	105.000	104.980	160.000	159.975	35.00	34.60	32.50	32.00	35.00	148.00	12.30	2.0	2	1,850	2,930
GAC110T	110.000	109.980	170.000	169.975	38.00	37.60	34.00	33.50	38.00	155.00	13.00	2.0	3	2,020	3,680
GAC120T	120.000	119.980	180.000	179.975	38.00	37.60	37.00	36.50	38.00	168.00	14.50	2.0	.5	2,390	3,970
GAC130T	130.000	129.975	200.000	199.970	45.00	44.50	43.00	42.40	45.00	188.00	18.00	2.5	1	3,110	5,920
GAC140T	140.000	139.975	210.000	209.970	45.00	44.50	43.00	42.40	45.00	198.00	19.00	2.5	1	3,270	6,330
GAC150T	150.000	149.975	225.000	224.970	48.00	47.50	46.00	45.40	48.00	211.00	20.00	3.0	1	3,730	8,010
GAC160T	160.000	159.975	240.000	239.970	51.00	50.50	49.00	48.40	51.00	225.00	20.00	3.0	1	4,240	9,790
GAC170T	170.000	169.975	260.000	259.965	57.00	56.50	55.00	54.30	57.00	246.00	21.00	3.0	1	5,200	12,300
GAC180T	180.000	179.975	280.000	279.965	64.00	63.50	61.00	60.30	64.00	260.00	21.00	3.0	1	6,100	17,400
GAC190T	190.000	189.970	290.000	289.965	64.00	63.40	62.00	61.30	64.00	275.00	26.00	3.0	.5	6,560	18,200
GAC200T	200.000	199.970	310.000	309.965	70.00	69.40	66.00	65.30	70.00	290.00	26.00	3.0	1.5	7,360	23,800

FRACTURED RACE* BEARINGS INTERCHANGE GUIDE

*Also known as a split race bearings or light series bearings



These types of bearings are first and foremost intended for static situations where potential misalignments exist that can not be accommodated by plane bushings or clevises and pins.

While these bearings are most commonly used in applications with heavy static loads with initial or assembly misalignment, they are also used for dynamic applications with slow dynamic misalignment, either pivotal, rotational, or combination. For dynamic applications subject to regular misalignment, a full swage bearing such as the COM series is recommended.

Aurora	IKO	INA	RBC	SKF	Torrington
GEZ X ES	SBB X	GE W ZO	B X -L	GEZ V ES	U SF X
GE Y ES	GE Y ES	GE Y DO	MB Y	GE Y ES	Y FS Y*
GEZ X ET-2RS			B X FSS	GEZ V TE-2RS	U SFL X
GE Y ET-2RS	GE Y EC-2RS	GE Y UK-2RS	MB Y FSS	GE Y TE-2RS	
GEG Y ES	GE Y GS	GE Y FO	MBH Y**	GEH Y ES	Y FSH Y*
GEEW Y ES		GE Y LO	MB Y -E	GEG Y ES	
GEWZ X ES			B X -EL	GEZM V ES	
GAC Y S		GE Y SX	MB Y -SA		
GACZ X S			B X -SA	GAZ V SA	U SBT X
GAC Y T		GE Y SW		GAC Y F	
Seals: -2 RS	-2 RS	-2 RS	SS	-2 RS	TT, SS

U = Approximate bore in inches. (ex. 5 = .5", 15 = 1.5")

V = Below 1", Bore in 1/16". Above 1" bore in whole inch + fraction in 1/16" (ex. 8 = 1/2", 108 = 1 1/2")

W = Bore is nearest metric equivalent for inch size. (ex. 12 = .5", .5" = 12.7 mm.)

X = Bore in 1/16". (ex. 8 = 1/2", 1/2" = 8/16")

Y = Bore in mm. (ex. 20 = 20mm.)

Y* = OD in mm.

Y** = Bore in mm. + bore of next size part offered (ex. 2025 = 20mm. bore, 25mm is bore of next larger size part offered)

Table to be used as a reference guide. Ultimate interchangeability should be determined by comparing relevant manufacturers specifications.



SUGGESTED HOUSING BORES

Spherical Plain Bearings

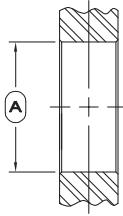

- ISO H7** - Fit recommended for light loads where axial displacement is required after installation.
- ISO M7** - Press fit where bearing is subjected to combination, reversing, or shock loads.
- ISO N7** - Recommended fit when using a light alloy housing (i.e. aluminum).
- EXTRA HEAVY PRESS FIT** - Recommended fit for applications with extreme shock loads that can also tolerate elevated breakaway torques. A sufficiently rigid housing is assumed.



Tables are representative of Metal to Metal parts, please consult our engineering department regarding PTFE lined parts.

For GEG, GEGZ, GEW, GEWZ, GAC, GACZ series.

BEARING SERIES GE..ES GEZ..ES..2RS	DIMENSIONS IN INCHES									
	A Suggested Housing Bore For Press Fit of Spherical Plain Bearings									
	Bearing Outside Diameter		ISO H7		ISO M7		ISO N7		Extra Heavy Press Fit	
	Max.	Min.	Max.	Min.	Max.	Min.	Max.	Min.	Max.	Min.
008	.8750	.8745	.8758	.8750	.8750	.8742	.8747	.8739	.8743	.8735
010	1.0625	1.0620	1.0633	1.0625	1.0625	1.0617	1.0622	1.0614	1.0610	1.0620
012	1.2500	1.2495	1.2510	1.2500	1.2500	1.2490	1.2497	1.2487	1.2485	1.2475
014	1.4375	1.4370	1.4385	1.4375	1.4375	1.4365	1.4372	1.4362	1.4360	1.4350
016	1.6250	1.6245	1.6260	1.6250	1.6250	1.6240	1.6247	1.6237	1.6235	1.6225
020	2.0000	1.9995	2.0012	2.0000	2.0000	1.9988	1.9996	1.9985	1.9987	1.9975
022	2.1875	2.1870	2.1887	2.1875	2.1875	2.1863	2.1871	2.1860	2.1862	2.1850
024	2.4375	2.4370	2.4387	2.4375	2.4375	2.4363	2.4371	2.4360	2.4362	2.4350
028	2.8125	2.8120	2.8137	2.8125	2.8125	2.8113	2.8210	2.8110	2.8112	2.8100
032	3.1875	3.1869	3.1889	3.1875	3.1875	3.1861	3.1871	3.1857	3.1859	3.1845
036	3.5625	3.5619	3.5639	3.5625	3.5625	3.5611	3.5621	3.5607	3.5604	3.5590
040	3.9375	3.9369	3.9389	3.9375	3.9375	3.9361	3.9357	3.9371	3.9354	3.9340
044	4.3750	4.3744	4.3764	4.3750	4.3750	4.3736	4.3746	4.3732	4.3729	4.3715
048	4.7500	4.7493	4.7516	4.7500	4.7500	4.7484	4.7495	4.7418	4.7476	4.7460
052	5.1250	5.1243	5.1266	5.1250	5.1250	5.1234	5.1245	5.1230	5.1226	5.1210
056	5.5000	5.4993	5.5016	5.5000	5.5000	5.4984	5.4995	5.4980	5.4976	5.4960
060	5.8750	5.8743	5.8766	5.8750	5.8750	5.8734	5.8745	5.8730	5.8726	5.8710
064	6.2500	6.2490	6.2516	6.2500	6.2500	6.2484	6.2495	6.2480	6.2476	6.2460
068	6.6250	6.6240	6.6266	6.6250	6.6250	6.6234	6.6245	6.6230	6.6226	6.6210
072	7.0000	6.9990	7.0016	7.0000	7.0000	6.9984	6.9995	6.9980	6.9976	6.9960
076	7.3750	7.3740	7.3768	7.3750	7.3750	7.3732	7.3744	7.3726	7.3728	7.3710
080	7.7500	7.7490	7.7518	7.7500	7.7500	7.7482	7.7494	7.7476	7.7478	7.7460
096	8.7500	8.7490	8.7518	8.7500	8.7500	8.7482	8.7494	8.7476	8.7478	8.7460

BEARING SERIES GE..ES GE..ES..2RS	DIMENSIONS IN MILLIMETERS									
	A Suggested Housing Bore For Press Fit of Spherical Plain Bearings									
	Bearing Outside Diameter		ISO H7		ISO M7		ISO N7		Extra Heavy Press Fit	
	Max.	Min.	Max.	Min.	Max.	Min.	Max.	Min.	Max.	Min.
12	22.000	21.991	22.021	22.000	22.000	21.979	21.993	21.972	21.982	21.962
15	26.000	25.991	26.021	26.000	26.000	25.979	25.993	25.972	25.962	25.937
17	30.000	29.991	30.021	30.000	30.000	29.979	29.993	29.972	29.962	29.937
20	35.000	34.989	35.025	35.000	35.000	34.975	34.992	34.967	34.962	34.937
25	42.000	41.989	42.025	42.000	42.000	41.975	41.992	41.967	41.967	41.937
30	47.000	46.989	47.025	47.000	47.000	46.975	46.992	46.967	46.967	46.937
35	55.000	54.987	55.030	55.000	55.000	54.970	54.991	54.961	54.967	54.937
40	62.000	61.987	62.030	62.000	62.000	61.970	61.991	61.961	61.967	61.937
45	68.000	67.987	68.030	68.000	68.000	67.970	67.991	67.961	67.967	67.937
50	75.000	74.987	75.030	75.000	75.000	74.970	74.991	74.961	74.967	74.937
60	90.000	89.985	90.035	90.000	90.000	89.965	89.990	89.955	89.967	89.911
70	105.000	104.985	105.035	105.000	105.000	104.965	104.990	104.955	104.967	104.911
80	120.000	119.985	120.035	120.000	120.000	119.965	119.990	119.955	119.967	119.911
90	130.000	129.982	130.040	130.000	130.000	129.960	129.988	129.948	129.939	129.898
100	150.000	149.982	150.040	150.000	150.000	149.960	149.988	149.948	149.939	149.898
110	160.000	159.975	160.040	160.000	160.000	159.960	159.988	159.948	159.939	159.898
120	180.000	179.975	180.040	180.000	180.000	179.960	179.988	179.948	179.939	179.898
140	210.000	209.970	210.046	210.000	210.000	209.954	209.949	209.940	209.995	209.898
160	230.000	229.970	230.046	230.000	230.000	229.954	229.949	229.940	229.995	229.898

SUGGESTED HOUSING BORES

COM, HCOM, MIB, AIB & SIB Spherical Bearings

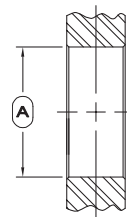

COM & HCOM Series

BEARING SERIES COM HCOM	DIMENSIONS IN INCHES				
	(A) Suggested Housing Bore For Press Fit of Spherical Bearings				
	Bearing Outside Diameter +.0000 -.0007	Steel Housing		Aluminum Housing	
Max.		Min.	Max.	Min.	
3	.5625	.5619	.5614	.5618	.5612
4	.6562	.6556	.6551	.6555	.6549
5	.7500	.7494	.7489	.7493	.7487
6	.8125	.8119	.8114	.8118	.8112
7	.9062	.9056	.9051	.9055	.9049
8	1.0000	.9994	.9989	.9993	.9987
9	1.0937	1.0931	1.0925	1.0930	1.0923
10	1.1875	1.1869	1.1863	1.1868	1.1861
12	1.4375	1.4369	1.4363	1.4368	1.4361
14	1.5625	1.5619	1.5613	1.5618	1.5611
16	1.7500	1.7494	1.7486	1.7493	1.7485
16	2.0000	1.9994	1.9986	1.9993	1.9985
19	2.3750	2.3744	2.3736	2.3743	2.3735
20	2.3750	2.3744	2.3736	2.3743	2.3735
24	2.7500	2.7494	2.7486	2.7493	2.7485
28	3.1250	3.1244	3.1236	3.1243	3.1235
32	3.5000	3.4994	3.4986	3.4993	3.4985

BEARING SERIES COM HCOM	DIMENSIONS IN MILLIMETERS				
	(A) Suggested Housing Bore For Press Fit of Spherical Bearings				
	Bearing Outside Diameter +.000 -.018	Steel Housing		Aluminum Housing	
Max.		Min.	Max.	Min.	
3	14.288	14.272	14.260	14.270	14.255
4	16.667	16.652	16.640	16.650	16.634
5	19.050	19.035	19.022	19.032	19.017
6	20.638	20.622	20.610	20.620	20.604
7	23.018	23.002	22.990	23.000	22.985
8	25.400	25.385	25.372	25.382	25.367
9	27.780	27.765	27.750	27.762	27.744
10	30.162	30.147	30.132	30.145	30.127
12	36.512	36.497	36.482	36.495	36.477
14	39.688	39.672	39.657	39.670	39.652
16	44.450	44.435	44.414	44.432	44.412
16	50.800	50.785	50.764	50.782	50.762
19	60.325	60.310	60.289	60.307	60.287
20	60.325	60.310	60.289	60.307	60.287
24	69.850	69.835	69.814	69.832	69.812
28	79.375	79.360	79.339	79.357	79.337
32	88.900	88.885	88.864	88.882	88.862

Dimensions given in the tables below are for bearings fabricated of standard race materials. Should other materials be used, consult our engineering department for modification of these dimensions.

Tables are representative of Metal to Metal parts, please consult our engineering department regarding PTFE lined parts.

MIB, AIB & SIB Series

BEARING SERIES MIB AIB SIB	DIMENSIONS IN INCHES				
	(A) Suggested Housing Bore For Press Fit of Spherical Bearings				
	Bearing Outside Diameter +.0000 -.0007	Steel Housing		Aluminum Housing	
Max.		Min.	Max.	Min.	
3	.5312	.5306	.5301	.5305	.5299
4	.6094	.6088	.6083	.6087	.6081
5	.7500	.7494	.7489	.7493	.7487
6	.8437	.8431	.8426	.8430	.8424
7	1.0000	.9994	.9989	.9993	.9987
8	1.0937	1.0931	1.0925	1.0930	1.0923
10	1.3125	1.3119	1.3113	1.3118	1.3111
12	1.5000	1.4994	1.4988	1.4993	1.4986
14	1.6250	1.6244	1.6236	1.6243	1.6235
16	2.1250	2.1244	2.1236	2.1243	2.1235

BEARING SERIES MIB AIB SIB	DIMENSIONS IN MILLIMETERS				
	(A) Suggested Housing Bore For Press Fit of Spherical Bearings				
	Bearing Outside Diameter +.000 -.018	Steel Housing		Aluminum Housing	
Max.		Min.	Max.	Min.	
3	13.492	13.477	13.465	13.475	13.460
4	15.479	15.464	15.451	15.461	15.446
5	19.050	19.035	19.022	19.032	19.017
6	21.430	21.415	21.402	21.412	21.397
7	25.400	25.385	25.372	25.382	25.367
8	27.780	27.765	27.750	27.762	27.744
10	33.338	33.322	33.307	33.320	33.302
12	38.100	38.085	38.070	38.082	38.064
14	41.275	41.259	41.239	41.257	41.237
16	53.975	53.960	53.939	53.957	53.937



SUGGESTED HOUSING BORES

LCOM & COM-M Spherical Bearings

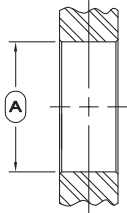

These tables are representative of Metal to Metal parts, please consult our engineering department regarding PTFE lined parts.

LCOM SERIES

COM-M SERIES

BEARING SERIES	DIMENSIONS IN INCHES				
	Suggested Housing Bore For Press Fit of Spherical Bearings				
	Bearing Outside Diameter +.0000 -.0007	Steel Housing		Aluminum Housing	
Max.		Min.	Max.	Min.	
3	.6250	.6244	.6239	.6243	.6237
4	.7500	.7494	.7489	.7493	.7487
5	.8750	.8744	.8739	.8743	.8737
6	1.0000	.9994	.9989	.9993	.9987
7	1.1875	1.1869	1.1863	1.1868	1.1861
8	1.3125	1.3119	1.3113	1.3118	1.3111
10	1.5625	1.5619	1.5613	1.5618	1.5611
12	2.2500	2.2494	2.2486	2.2493	2.2485
12-1	1.8750	1.8744	1.8736	1.8743	1.8735
16	2.3750	2.3744	2.3736	2.3743	2.3735
19	2.6250	2.6244	2.6236	2.6243	2.6235
24	3.2500	3.2494	3.2486	3.2493	3.2485
30	4.0000	3.9994	3.9986	3.9993	3.9985

BEARING SERIES	DIMENSIONS IN INCHES				
	Suggested Housing Bore For Press Fit of Metric Spherical Bearings				
	Bearing Outside Diameter +.0000 -.0007	Steel Housing		Aluminum Housing	
Max.		Min.	Max.	Min.	
3	.4724	.4718	.4713	.4717	.4711
5	.6299	.6293	.6288	.6292	.6286
6	.7087	.7081	.7076	.7080	.7074
8	.8661	.8655	.8650	.8654	.8648
10	1.0236	1.0230	1.0225	1.0229	1.0223
12	1.1811	1.1805	1.1799	1.1804	1.1797
14	1.3386	1.3380	1.3374	1.3379	1.3372
16	1.4961	1.4955	1.4949	1.4954	1.4947
18	1.6535	1.6529	1.6523	1.6528	1.6521
20	1.8110	1.8104	1.8096	1.8103	1.8095
22	1.9685	1.9679	1.9671	1.9678	1.9670
25	2.2047	2.2041	2.2033	2.2040	2.2032
30	2.5984	2.5978	2.5970	2.5977	2.5969

BEARING SERIES	DIMENSIONS IN MILLIMETERS				
	Suggested Housing Bore For Press Fit of Spherical Bearings				
	Bearing Outside Diameter +.000 -.018	Steel Housing		Aluminum Housing	
Max.		Min.	Max.	Min.	
3	15.875	15.860	15.847	15.857	15.842
4	19.050	19.035	19.022	19.032	19.017
5	22.225	22.210	22.197	22.207	22.192
6	25.400	25.385	25.372	25.382	25.367
7	30.163	30.148	30.132	30.145	30.127
8	33.338	33.323	33.307	33.320	33.302
10	39.688	39.673	39.657	39.670	39.652
12	57.150	57.135	57.114	57.132	57.112
12-1	47.625	47.610	47.589	47.607	47.587
16	60.325	60.310	60.289	60.307	60.287
19	66.675	66.660	66.639	66.657	66.637
24	82.550	82.535	82.514	82.532	82.512
30	101.600	101.585	101.564	101.582	101.562

BEARING SERIES	DIMENSIONS IN MILLIMETERS				
	Suggested Housing Bore For Press Fit of Metric Spherical Bearings				
	Bearing Outside Diameter +.000 -.018	Steel Housing		Aluminum Housing	
Max.		Min.	Max.	Min.	
3	12	11.985	11.972	11.982	11.967
5	16	15.985	15.972	15.982	15.967
6	18	17.985	17.972	17.982	17.967
8	22	21.985	21.972	21.982	21.967
10	26	25.985	25.972	25.982	25.967
12	30	29.985	29.969	29.982	29.964
14	34	33.985	33.969	33.982	33.964
16	38	37.985	37.969	37.982	37.964
18	42	41.985	41.969	41.982	41.964
20	46	45.985	45.964	45.982	45.962
22	50	49.985	49.964	49.982	49.962
25	56	55.985	55.964	55.982	55.962
30	66	65.985	65.964	65.982	65.962

HB SERIES

Ball Bearing, Self-aligning Rod Ends

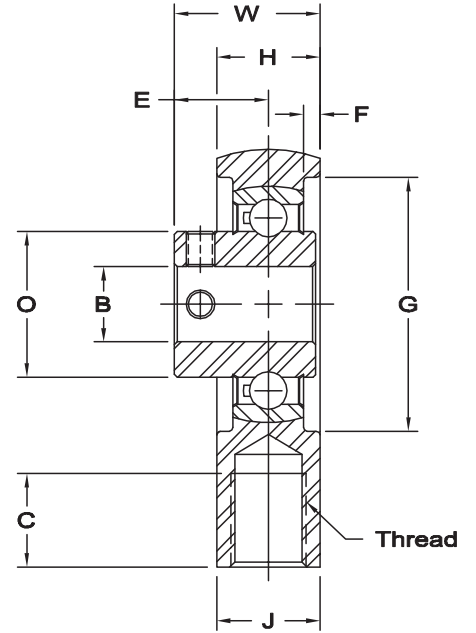
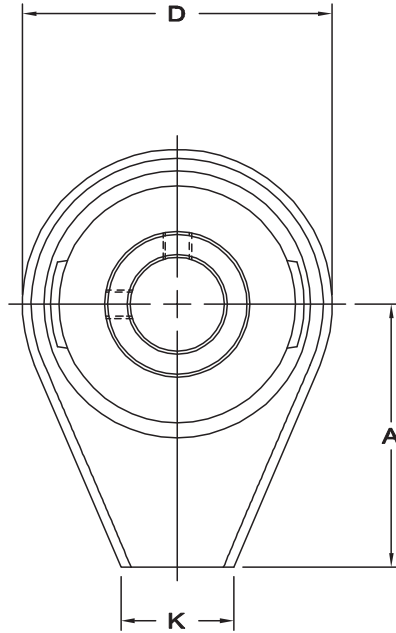

**HOUSING MATERIAL -
DUCTILE IRON**

Consult our Engineering Department for load ratings and RPM information.

Shaft Dia.	Unit No.	DIMENSIONS IN INCHES												Approx. Brg. Wt. Lbs.	
		A	B Ref.	C	D	E	F	G	H	J	K	O	W		Thread Size
1/2"	HB-8	1 3/4	.500	5/8	2 1/16	5/8	7/64	1 11/16	11/16	11/16	3/4	.961	31/32	1/2 20 UNF	.63
5/8"	HB-10	1 3/4	.625	5/8	2 1/16	5/8	7/64	1 11/16	11/16	11/16	3/4	.961	31/32	1/2 20 UNF	.63
3/4"	HB-12	1 13/16	.750	1/2	2 1/4	23/32	3/32	1 15/16	3/4	3/4	13/16	1.165	1 3/32	1/2 13 UNC	.75

Shaft Dia.	Unit No.	DIMENSIONS IN MILLIMETERS												Approx. Brg. Wt. Lbs.	
		A	B Ref.	C	D	E	F	G	H	J	K	O	W		Thread Size
1/2"	HB-8	44.45	12.70	15.88	52.37	15.88	2.78	42.86	17.46	17.46	19.05	24.41	24.61	1/2 20 UNF	284
5/8"	HB-10	44.45	15.88	15.88	52.37	15.88	2.78	42.86	17.46	17.46	19.05	24.41	24.61	1/2 20 UNF	284
3/4"	HB-12	46.04	19.05	12.70	57.15	18.26	2.38	49.21	19.05	19.05	20.64	29.59	27.78	1/2 13 UNC	341

XAM & XAB SERIES MALE ROD ENDS

High Strength Alloy – Heavy Duty Shank (PTFE Liners Available)



Body - Alloy steel, heat treated, protective coated for corrosion resistance.

Race - Alloy steel, heat treated protective coated for corrosion resistance. (Carbon steel with PTFE liners.)

Ball - Alloy steel, heat treated, hard chrome plated.

Notes - All sizes available with studs upon request.

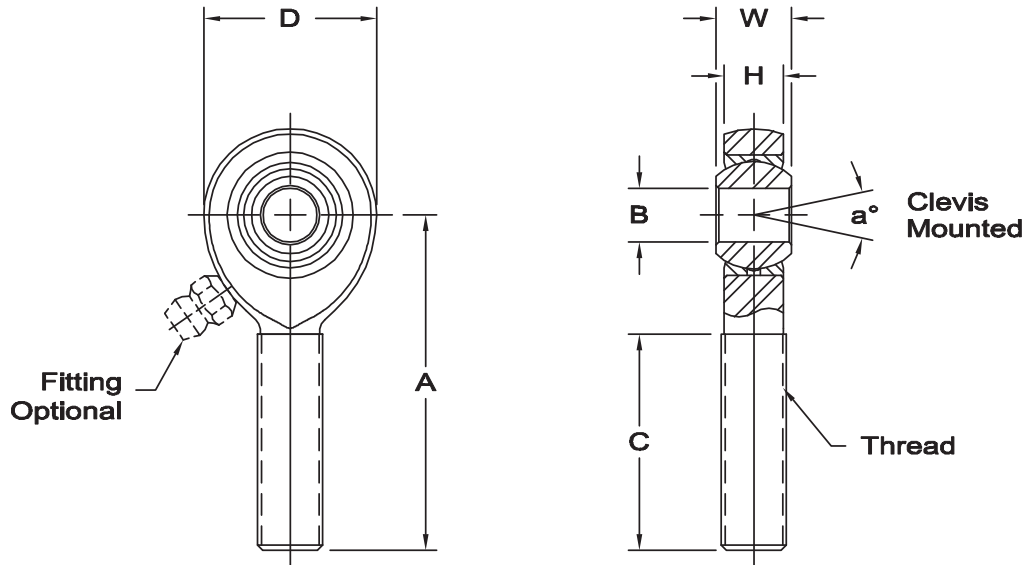

Units are supplied without grease fittings. When a grease fitting is required, specify by adding suffix as designated.

- Z Zerk type fitting Ex: XAM 6Z
- F Flush type fitting Ex: XAM 6F
- T PTFE Liner Ex: XAM 6T

Load ratings apply only to rod ends without grease fittings. For load ratings with fittings, please consult our engineering department.

ROD END NO.		DIMENSIONS IN INCHES								a° Misalign. Angle	Ultimate Radial Static Load Capacity Lbs.	Approx. Brg. Wt. Lbs.
Right Hand	Left Hand	B + .0015 - .0005	W + .000 - .005	H ± .005	A ± .015	D ± .010	Ball Dia. Ref.	C + .062 - .031	Thread UNF-3A			
XAM-3	XAB-3	.1900	.312	.250	1.562	.750	.437	1.000	1/4 28	10	5,260	.04
XAM-4	XAB-4	.2500	.375	.281	1.875	.875	.500	1.250	5/16 24	13	8,452	.07
XAM-5	XAB-5	.3125	.437	.344	1.938	1.000	.625	1.250	3/8 24	12	12,978	.11
XAM-6	XAB-6	.3750	.500	.406	2.125	1.125	.719	1.375	7/16 20	10	17,508	.16
XAM-7	XAB-7	.4375	.562	.437	2.438	1.312	.812	1.500	1/2 20	12	23,452	.25
XAM-8	XAB-8	.5000	.625	.500	2.625	1.500	.937	1.625	5/8 18	10	31,390	.38
XAM-10	XAB-10	.6250	.750	.562	2.875	1.750	1.125	1.750	3/4 16	13	40,572	.60
XAM-12	XAB-12	.7500	.875	.687	3.375	2.000	1.312	1.875	7/8 14	12	55,692	.92

ROD END NO.		DIMENSIONS IN MILLIMETERS								a° Misalign. Angle	Ultimate Radial Static Load Capacity Newtons	Approx. Brg. Wt. Grams
Right Hand	Left Hand	B + .038 - .013	W + .00 - .13	H ± .13	A ± .38	D ± .25	Ball Dia. Ref.	C + 1.57 - .79	Thread UNF-3A			
XAM-3	XAB-3	4.826	7.92	6.35	39.67	19.05	11.10	25.40	1/4 28	10	23,397	20
XAM-4	XAB-4	6.350	9.53	7.14	47.63	22.23	12.70	31.75	5/16 24	13	37,596	33
XAM-5	XAB-5	7.938	11.10	8.74	49.23	25.40	15.88	31.75	3/8 24	12	57,728	51
XAM-6	XAB-6	9.525	12.70	10.31	53.98	28.58	18.26	34.93	7/16 20	10	77,880	73
XAM-7	XAB-7	11.113	14.27	11.10	61.93	33.32	20.62	38.10	1/2 20	12	104,317	113
XAM-8	XAB-8	12.700	15.88	12.70	66.68	38.10	23.80	41.28	5/8 18	10	139,628	173
XAM-10	XAB-10	15.875	19.05	14.27	73.02	44.45	28.58	44.45	3/4 16	13	180,461	273
XAM-12	XAB-12	19.050	22.23	17.45	85.73	50.80	33.32	47.63	7/8 14	12	247,721	427



RAM, RAB, RXAM, RXAB SERIES MALE ROD ENDS

High Strength Alloy (PTFE Liners Available)

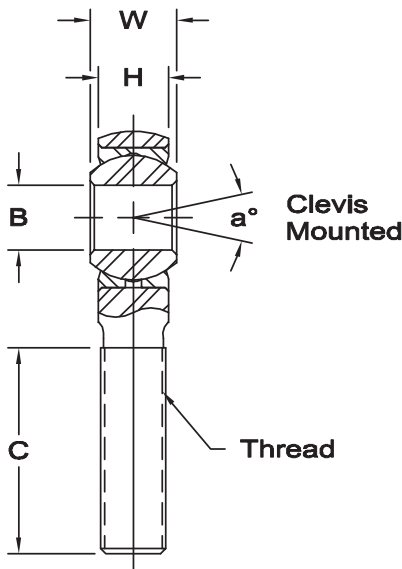
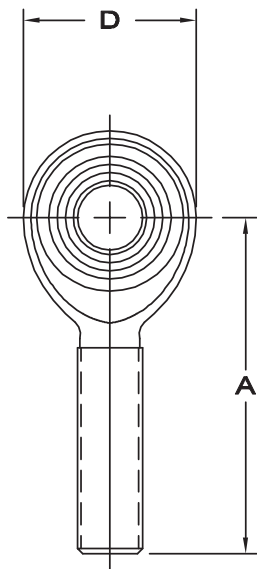

RAM



RXAM

Body - Alloy steel, heat treated, nickel or chrome plated.

Race - Alloy steel, heat treated, nickel plated.

Ball - Alloy steel, heat treated, hard chrome plated.

PTFE Liners use suffix T Ex: RAM 10T

1 Threads UNF 3A

RAM – HEAVY DUTY

ROD END NO.		DIMENSIONS IN INCHES								a° Misalign. Angle	Ultimate Radial Static Load Capacity Lbs.	Approx. Brg. Wt. Lbs.
Right Hand	Left Hand	B +.0015 -.0005	W +.000 -.005	H ±.005	A ±.010	D +.000 -.020	Ball Dia. Ref.	C +.062 -.031	Thread UNJF-3A			
RAM-3	RAB-3	.1900	.312	.250	1.250	.625	.437	.750	10 32 ₁	13	2,851	.03
RAM-4	RAB-4	.2500	.375	.281	1.562	.750	.500	1.000	1/4 28	16	5,260	.04
RAM-5	RAB-5	.3125	.437	.344	1.875	.875	.625	1.187	5/16 24	14	7,125	.07
RAM-6	RAB-6	.3750	.500	.406	1.938	1.000	.719	1.187	3/8 24	12	8,939	.11
RAM-7	RAB-7	.4375	.562	.437	2.125	1.125	.812	1.312	7/16 20	14	9,653	.16
RAM-8	RAB-8	.5000	.625	.500	2.438	1.312	.937	1.437	1/2 20	12	15,500	.25
RAM-10	RAB-10	.6250	.750	.562	2.625	1.500	1.125	1.562	5/8 18	16	17,148	.38
* RAM-10-12	RAB-10-12	.6250	.875	.687	2.875	1.750	1.312	1.687	3/4 16	14	27,021	.60
RAM-12	RAB-12	.7500	.875	.687	2.875	1.750	1.312	1.687	3/4 16	14	27,021	.60

RXAM – EXTRA HEAVY DUTY

ROD END NO.		DIMENSIONS IN INCHES								a° Misalign. Angle	Ultimate Radial Static Load Capacity Lbs.	Approx. Brg. Wt. Lbs.
Right Hand	Left Hand	B +.0015 -.0005	W +.000 -.005	H ±.005	A ±.010	D +.000 -.020	Ball Dia. Ref.	C +.062 -.031	Thread UNJF-3A			
RXAM-3	RXAB-3	.1900	.312	.250	1.562	.750	.437	1.000	1/4 28	10	5,260	.04
RXAM-4	RXAB-4	.2500	.375	.281	1.875	.875	.500	1.187	5/16 24	13	8,452	.07
RXAM-5	RXAB-5	.3125	.437	.344	1.938	1.000	.625	1.187	3/8 24	12	12,978	.11
RXAM-6	RXAB-6	.3750	.500	.406	2.125	1.125	.719	1.312	7/16 20	10	17,508	.16
RXAM-7	RXAB-7	.4375	.562	.437	2.438	1.312	.812	1.437	1/2 20	12	22,760	.25
RXAM-8	RXAB-8	.5000	.625	.500	2.625	1.500	.937	1.562	5/8 18	10	30,579	.38
RXAM-10	RXAB-10	.6250	.750	.562	2.875	1.750	1.125	1.687	3/4 16	13	39,674	.60



HXAM-T



Body - 4340 steel, heat treated, protective coated for corrosion resistance.

Race - 4130 steel, heat treated, protective coated for corrosion resistance.

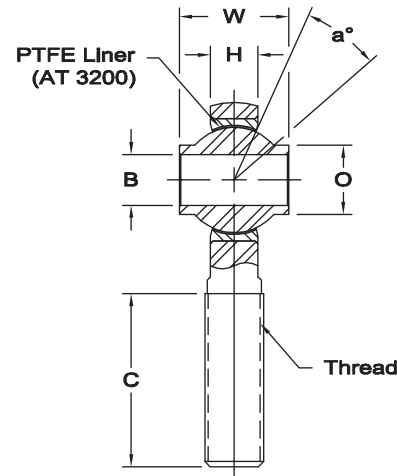
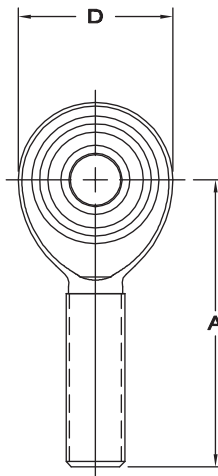

Ball - Alloy steel, heat treated, hard chrome plated.

PTFE liner - (AT 3200)
Permanently bonded to race inside diameter. Qualified to SAE-AS81820 (formerly MIL-B-81820)

HAB-T, HAB-TG

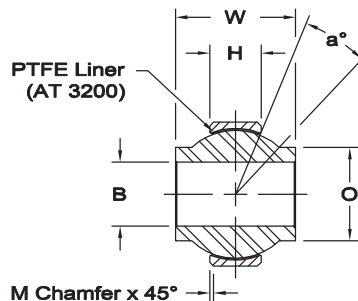
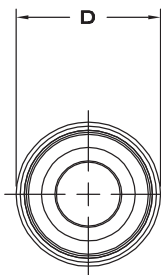
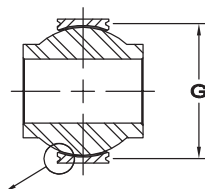
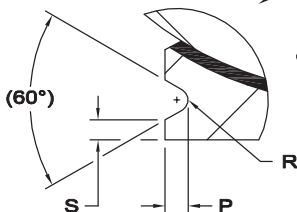

GROOVED SERIES

PLAIN SERIES

HXAM-T

ROD END NO.		DIMENSIONS IN INCHES									a° Misalign. Angle	Ultimate Radial Static Load Capacity Lbs.	Approx. Brg. Wt. Lbs.
Right Hand	Left Hand	B +.0000 -.0005	W +.000 -.005	H ±.005	A ±.010	D ±.010	Ball Dia. Ref.	C ±.031	Thread UNJF-3A	O Shoulder Dia.			
HXAM-4T	HXAB-4T	.2500	.593	.265	1.938	1.025	.593	1.187	3/8 24	.390	23	10,789	.12
HXAM-5T	HXAB-5T	.3125	.813	.355	2.125	1.150	.781	1.281	7/16 20	.512	22	11,781	.16
HXAM-6T	HXAB-6T	.3750	.813	.355	2.125	1.150	.781	1.281	7/16 20	.512	22	11,781	.15
HXAM-7T	HXAB-7T	.4375	.875	.355	2.438	1.337	.875	1.468	1/2 20	.618	21	17,105	.24
HXAM-8T	HXAB-8T	.5000	.937	.411	2.625	1.525	1.000	1.562	5/8 18	.730	19	23,720	.39
HXAM-10T	HXAB-10T	.6250	1.200	.577	2.875	1.775	1.250	1.687	3/4 16	.856	19	32,067	.60
HXAM-12T	HXAB-12T	.7500	1.280	.630	3.375	2.025	1.375	2.000	7/8 14	.970	18	38,660	.89

HAB-T

BEARING NO.		DIMENSIONS IN INCHES											a° Misalign. Angle	Radial Static Limit Load Capacity Lbs.	Approx. Brg. Wt. Lbs.
Grooved	Plain	B +.0000 -.0005	D +.0000 -.0005	W +.000 -.005	H ±.005	M Ref.	O Ref.	P +.000 -.010	S Min.	G +.000 -.008	R +.002 -.005	Ball Dia. Ref.			
HAB-4TG	HAB-4T	.2500	.7400	.593	.255	.020	.390	.025	.010	.674	.010	.593	24	7,560	.04
HAB-5TG	HAB-5T	.3125	.9060	.813	.345	.030	.512	.025	.010	.840	.010	.781	23	16,975	.08
HAB-6TG	HAB-6T	.3750	.9060	.813	.345	.030	.512	.025	.010	.840	.010	.781	23	16,975	.07
HAB-7TG	HAB-7T	.4375	1.0000	.875	.345	.030	.618	.025	.010	.934	.010	.875	22	19,018	.09
HAB-8TG	HAB-8T	.5000	1.1250	.937	.401	.030	.730	.025	.010	1.059	.010	1.000	20	25,263	.13
HAB-10TG	HAB-10T	.6250	1.3750	1.200	.567	.030	.856	.035	.020	1.279	.015	1.250	20	44,651	.25
HAB-12TG	HAB-12T	.7500	1.5625	1.280	.620	.035	.970	.035	.020	1.467	.015	1.375	18	53,707	.33
HAB-14TG	HAB-14T	.8750	1.7500	1.400	.630	.039	1.140	.035	.020	1.654	.015	1.531	18	72,424	.44



PERFORMANCE RACING SERIES

PRM-T & PRXM-T Series Male Rod Ends - PTFE Lined

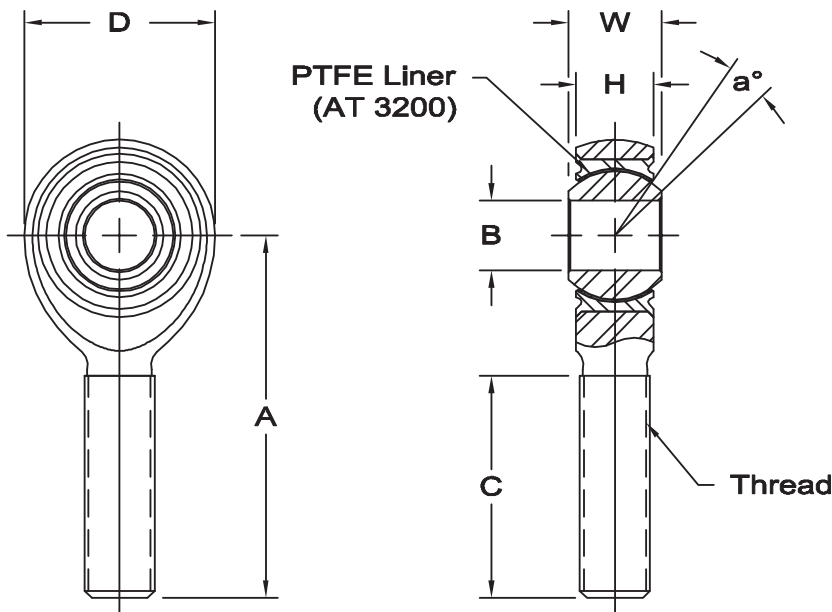

PRM-T

PRXM-T

Body - 4340 steel, heat treated, protective coated for corrosion resistance.

Race - Stainless steel (17-4 PH per AMS 5643), heat treated

Ball - Alloy steel, heat treated, hard chrome plated. Manufacturers option: 440C stainless steel, heat treated.

PTFE liner - (AT 3200) Permanently bonded to race inside diameter. Qualified to SAE-AS81820 (formerly MIL-B-81820)

PRM-T - PERFORMANCE RACING SERIES

ROD END NO.		DIMENSIONS IN INCHES									a° Misalign. Angle	Ultimate Radial Static Load Capacity Lbs.	No Load Rotational Breakaway Torque In-Lbs.	Approx. Brg. Wt. Lbs.
Right Hand	Left Hand	B +.0000 -.0005	W +.000 -.005	H ±.005	A ±.010	D ±.010	Ball Dia. Ref.	C ±.031	Thread UNJF-3A					
PRM-5T	PRB-5T	.3125	.437	.327	1.875	.900	.593	1.187	5/16 24	14	8,330	1 15	.09	
PRM-6T	PRB-6T	.3750	.500	.416	1.938	1.025	.687	1.187	3/8 24	8	10,946	1 15	.14	
PRM-7T	PRB-7T	.4375	.562	.452	2.125	1.150	.781	1.281	7/16 20	10	14,049	1 15	.18	
PRM-8T	PRB-8T	.5000	.625	.515	2.438	1.337	.875	1.468	1/2 20	9	23,310	1 15	.28	
PRM-10T	PRB-10T	.6250	.750	.577	2.625	1.525	1.062	1.562	5/8 18	12	25,909	1 15	.42	
PRM-12T	PRB-12T	.7500	.875	.640	2.875	1.775	1.250	1.687	3/4 16	13	34,319	1 15	.64	

PRXM-T - PERFORMANCE RACING - HEAVY DUTY SHANK SERIES

ROD END NO.		DIMENSIONS IN INCHES									a° Misalign. Angle	Ultimate Radial Static Load Capacity Lbs.	No Load Rotational Breakaway Torque In-Lbs.	Approx. Brg. Wt. Lbs.
Right Hand	Left Hand	B +.0000 -.0005	W +.000 -.005	H ±.005	A ±.010	D ±.010	Ball Dia. Ref.	C ±.031	Thread UNJF-3A					
PRXM-4T	PRXB-4T	.2500	.375	.337	1.562	.806	.531	.968	5/16 24	6	7,544	.5 6	.07	
PRXM-5T	PRXB-5T	.3125	.437	.327	1.875	.900	.593	1.187	3/8 24	14	9,135	1 15	.10	
PRXM-6T	PRXB-6T	.3750	.500	.416	1.938	1.025	.687	1.187	7/16 20	8	10,946	1 15	.15	
PRXM-7T	PRXB-7T	.4375	.562	.452	2.125	1.150	.781	1.281	1/2 20	10	14,049	1 15	.19	
PRXM-8T	PRXB-8T	.5000	.625	.515	2.438	1.337	.875	1.468	5/8 18	9	23,310	1 15	.32	
PRXM-10T	PRXB-10T	.6250	.750	.577	2.625	1.525	1.062	1.562	3/4 16	12	25,909	1 15	.46	

PERFORMANCE RACING SERIES

PNB-TG & PNB-T Series, PWB-TG & PWB-T Series Spherical Bearings - PTFE Lined

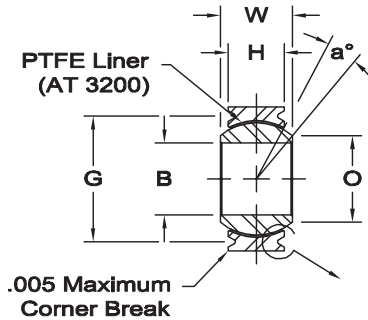

GROOVED SERIES

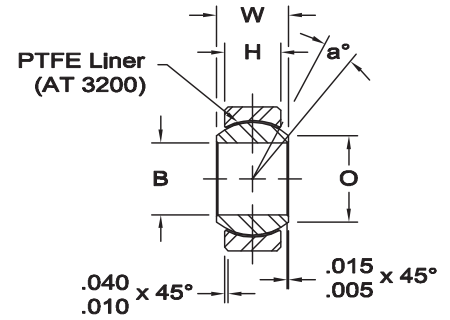
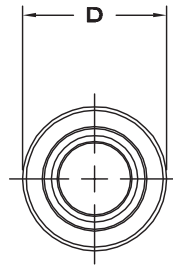

PLAIN SERIES

Ball - Alloy steel, heat treated, hard chrome plated. Manufacturers option: 440C stainless steel, heat treated.

Race - 17-4 PH stainless steel (AMS 5643), heat treated

PTFE Liner - (AT 3200)
Permanently bonded to race inside diameter.
Qualified to SAE-AS81820 (formerly MIL-B-81820)

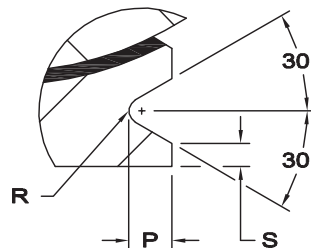

PNB-TG & PNB-T - PERFORMANCE RACING SPHERICAL NARROW SERIES

BEARING NO.		DIMENSIONS IN INCHES										a° Misalign. Angle	Static Limit Load		No Load Rotational Breakaway Torque In.-Lbs.	Approx. Brg. Wt. Lbs.	
Grooved	Plain	B	D	W	H	O	P	S	G	R	Ball Dia. Ref.		Radial Lbs.	Axial Lbs.			
PNB-3TG	PNB-3T	.1900	.5625	.281	.218	.293	.025	.010	.500	.010	.406	10	3,975	150	0.25	5.0	.02
PNB-4TG	PNB-4T	.2500	.6562	.343	.250	.364	.025	.010	.594	.010	.500	10	6,040	430	0.25	5.0	.02
PNB-5TG	PNB-5T	.3125	.7500	.375	.281	.419	.035	.020	.650	.010	.562	10	8,750	700	0.25	8.0	.03
PNB-6TG	PNB-6T	.3750	.8125	.406	.312	.475	.035	.020	.712	.015	.625	9	10,540	1,100	0.25	8.0	.04
PNB-7TG	PNB-7T	.4375	.9062	.437	.343	.530	.035	.020	.806	.015	.687	8	13,200	1,400	0.25	8.0	.05
PNB-8TG	PNB-8T	.5000	1.0000	.500	.390	.600	.055	.020	.876	.015	.781	8	17,900	2,100	0.25	8.0	.07
PNB-9TG	PNB-9T	.5625	1.0937	.562	.437	.670	.060	.020	.972	.015	.875	8	23,200	3,680	0.25	8.0	.09
PNB-10TG	PNB-10T	.6250	1.1875	.625	.500	.739	.055	.020	1.063	.015	.968	8	30,500	4,720	0.25	8.0	.12
PNB-12TG	PNB-12T	.7500	1.4375	.750	.593	.920	.055	.020	1.313	.015	1.187	8	46,400	6,750	0.25	8.0	.21

PWB-TG & PWB-T - PERFORMANCE RACING SPHERICAL WIDE SERIES

BEARING NO.		DIMENSIONS IN INCHES										a° Misalign. Angle	Static Limit Load		No Load Rotational Breakaway Torque In.-Lbs.	Approx. Brg. Wt. Lbs.	
Grooved	Plain	B	D	W	H	O	P	S	G	R	Ball Dia. Ref.		Radial Lbs.	Axial Lbs.			
PWB-3TG	PWB-3T	.1900	.6250	.437	.327	.300	.025	.010	.563	.010	.531	15	2,500	1,770	.25	5.0	.03
PWB-4TG	PWB-4T	.2500	.6250	.437	.327	.300	.025	.010	.563	.010	.531	15	5,500	1,770	.25	5.0	.03
PWB-5TG	PWB-5T	.3125	.6875	.437	.317	.360	.025	.010	.625	.010	.593	14	9,400	1,640	.25	8.0	.04
PWB-6TG	PWB-6T	.3750	.8125	.500	.406	.466	.035	.020	.712	.015	.687	8	13,700	2,630	.25	8.0	.06
PWB-7TG	PWB-7T	.4375	.9375	.562	.442	.537	.035	.020	.837	.015	.781	10	20,700	3,650	.25	8.0	.08
PWB-8TG	PWB-8T	.5000	1.0000	.625	.505	.607	.035	.020	.900	.015	.875	9	21,400	4,970	.25	8.0	.10
PWB-9TG	PWB-9T	.5625	1.1250	.687	.536	.721	.040	.020	1.025	.015	1.000	10	26,600	5,370	.25	8.0	.14
PWB-10TG	PWB-10T	.6250	1.1875	.750	.567	.747	.035	.020	1.087	.015	1.062	12	29,000	6,130	.25	8.0	.16
PWB-12TG	PWB-12T	.7500	1.3750	.875	.630	.845	.055	.020	1.251	.015	1.250	13	37,000	7,730	.25	8.0	.24



ALM & ALB SERIES XALM & XALB MALE ROD ENDS

(PTFE Liners Available)

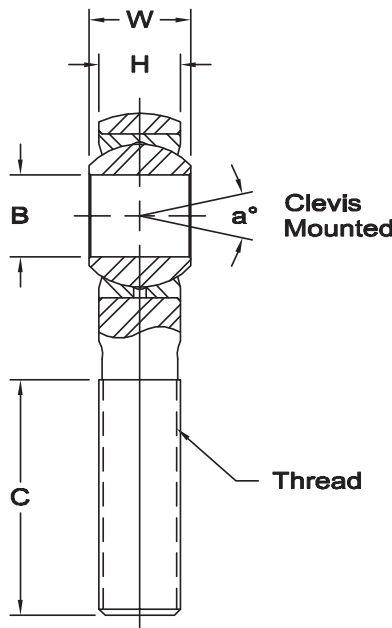
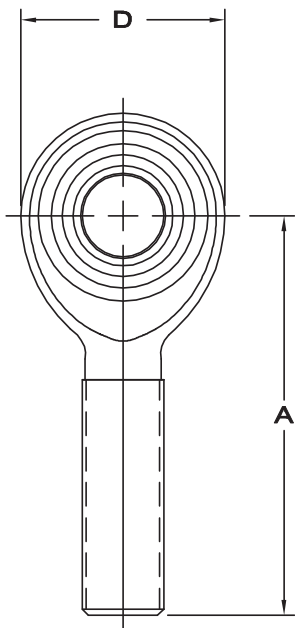

ALM



XALM

Body - Aluminum 7075-T651, hard anodized.

Race - Carbon steel, protective coated for corrosion resistance.

Ball - Alloy steel, heat treated, hard chrome plated.

* Threads are 1/2 20 UNJF 3A.

PTFE Liners use suffix T Ex: XALM 8T

ALM - ALUMINUM SERIES

ROD END NO.		DIMENSIONS IN INCHES								a° Misalign. Angle	Ultimate Radial Static Load Capacity Lbs.	Approx. Brg. Wt. Lbs.
Right Hand	Left Hand	B + .0015 - .0005	W + .000 - .005	H ± .005	A ± .015	D ± .010	Ball Dia. Ref.	C + .062 - .031	Thread UNF-3A			
ALM-8	ALB-8	.5000	.625	.500	2.438	1.250	.875	1.437	1/2 20*	13	7,596	.14
ALM-10	ALB-10	.6250	.750	.562	2.625	1.500	1.125	1.625	5/8 18	16	8,516	.24
ALM-12	ALB-12	.7500	.875	.687	2.875	1.750	1.312	1.750	3/4 16	14	13,319	.38

XALM - ALUMINUM SERIES

ROD END NO.		DIMENSIONS IN INCHES								a° Misalign. Angle	Ultimate Radial Static Load Capacity Lbs.	Approx. Brg. Wt. Lbs.
Right Hand	Left Hand	B + .0015 - .0005	W + .000 - .005	H ± .005	A ± .015	D ± .010	Ball Dia. Ref.	C + .062 - .031	Thread UNF-3A			
XALM-8	XALB-8	.5000	.625	.500	2.625	1.500	.937	1.625	5/8 18	10	14,889	.20
XALM-10	XALB-10	.6250	.750	.562	2.875	1.750	1.125	1.750	3/4 16	13	19,243	.31

MILITARY SPECIFICATION BEARINGS

General Information



Aurora Bearing Company's reputation for designing and producing high quality commercial rod ends and spherical bearings has grown extensively since the inception of the organization. Aurora Bearing has rapidly expanded its various product lines and now serves virtually every major industrial market.

In all of these markets, Aurora Bearing has consistently demonstrated its reputation for furnishing a reliable product. As a result, more and more firms sought help from our engineers and manufacturing specialists to solve difficult applications problems in high performance equipment. For example, Aurora Bearing was a pioneer in developing a special line of rod ends for the high temperature turbine engine industry.

Because of the special skills developed by our engineering and manufacturing personnel in the commercial bearing markets, our recognized expertise attracted the attention of the military specification bearing market, which includes the aircraft/aerospace industry. Frequently, our engineers have been

called upon to develop custom-designed units for sophisticated aerospace applications. In some instances, our standard commercial series of commercial rod ends and spherical bearings were more than adequate for aircraft/aerospace usage.

Consequently, Aurora Bearing Company decided to aggressively enter the military specification bearing marketplace. We now offer six standard lines that are presented in the following pages. Please note that the bearings listed utilize AT 3200, Aurora's exclusive PTFE bearing liner fully qualified to SAE-AS81820 (formerly MIL-B-81820). The bearings are manufactured to conform to the dimensions, materials and configurations of the appropriate individual military bearing specification. They are fully qualified and approved for procurement under these specifications. In addition, Aurora also has two standard lines of bearings in the general aviation field. Consult Aurora Bearing engineering for additional information.

Sales engineers specializing in the aviation field are available to discuss your particular application needs.

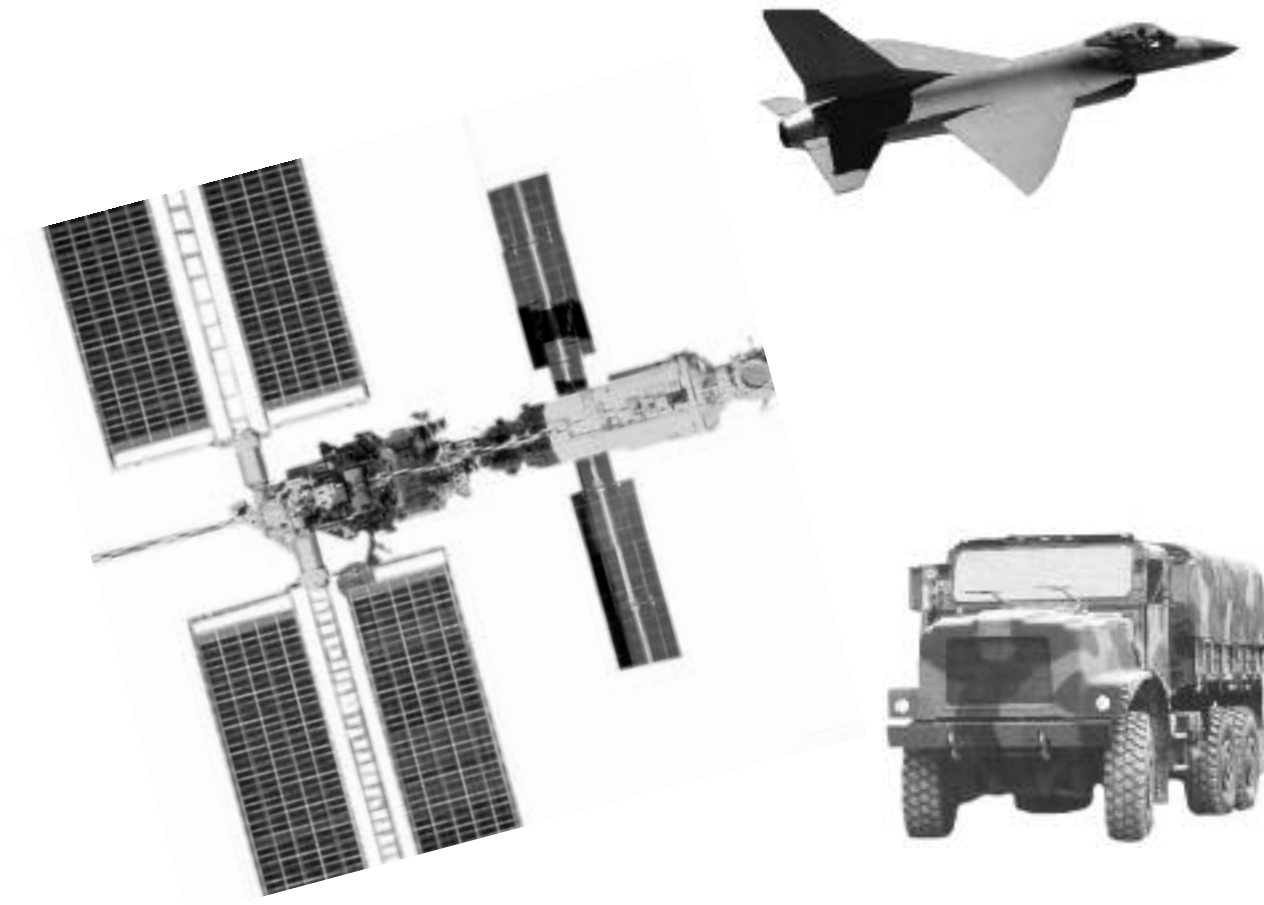



ASM-T & ASB-T MALE ROD ENDS

High Strength – Aerospace Series SAE-AS81935/1 (Right Hand) & SAE-AS81935/1 (Left Hand)

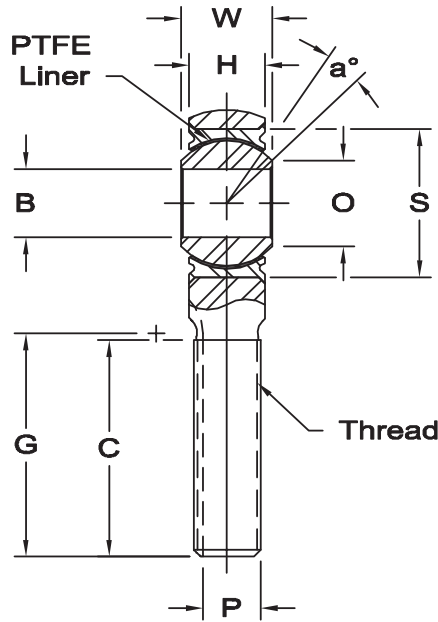
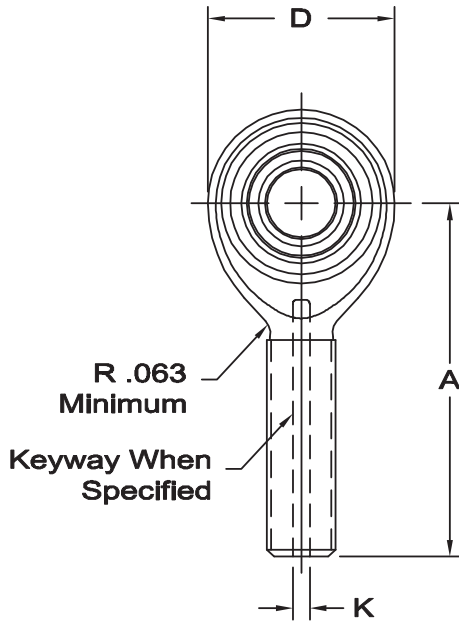

Body - 4340 Alloy steel (AMS-S-5000), heat treated, cadmium plated.

Ball - 440C stainless steel (AMS 5630), heat treated.

Race - 17-4 PH stainless steel (AMS 5643), heat treated.

Liner - AT 3200 bearing liner, permanently bonded to race I.D., qualified to SAE-AS81820.

TABLE I

ROD END NO.		DIMENSIONS IN INCHES													a° Misalign. Angle	Approx. Brg. Wt. Lbs.
Right Hand	Left Hand	B + .0000 - .0005	W + .000 - .002	H + .005	A ± .010	D ± .010	O Min.	S Max. Housing I.D.	Ball Dia. Ref.	G + .000 - .020	K + .005 - .000	P + .000 - .005	C ± .031	Thread UNJF-3A		
ASM-3T	ASB-3T	.1900	.437	.337	1.562	.806	.300	.6250	.531	.980	.062	.268	.968	5/16 24	15	.072
ASM-4T	ASB-4T	.2500	.437	.337	1.562	.806	.300	.6250	.531	.980	.062	.268	.968	5/16 24	15	.072
ASM-5T	ASB-5T	.3125	.437	.327	1.875	.900	.360	.6875	.593	1.270	.062	.268	1.187	5/16 24	14	.087
ASM-6T	ASB-6T	.3750	.500	.416	1.938	1.025	.470	.8125	.687	1.235	.093	.319	1.187	3/8 24	8	.136
ASM-7T	ASB-7T	.4375	.562	.452	2.125	1.150	.540	.9062	.781	1.402	.093	.383	1.281	7/16 20	10	.183
ASM-8T	ASB-8T	.5000	.625	.515	2.438	1.337	.610	1.0000	.875	1.589	.093	.445	1.468	1/2 20	9	.278
ASM-10T	ASB-10T	.6250	.750	.577	2.625	1.525	.750	1.1875	1.062	1.683	.125	.541	1.562	5/8 18	12	.424
ASM-12T	ASB-12T	.7500	.875	.640	2.875	1.775	.850	1.3750	1.250	1.808	.125	.663	1.687	3/4 16	13	.639
ASM-14T	ASB-14T	.8750	.875	.765	3.375	2.025	1.000	1.6250	1.375	2.121	.156	.777	2.000	7/8 14	6	.963
ASM-16T	ASB-16T	1.0000	1.375	1.015	4.125	2.775	1.270	2.1250	1.875	2.464	.187	1.136	2.343	1 1/4 12	12	2.546

TABLE II

ROD END NO.		Ultimate Radial Static Load Lbs.	Fatigue Load Lbs.	Axial Proof Load Lbs.	No Load Rotational Breakaway Torque* In-Lbs.	
Right Hand	Left Hand				Min.	Max.
ASM-3T	ASB-3T	2,360	1,470	1,000	.5	6
ASM-4T	ASB-4T	4,860	2,380	1,000	.5	6
ASM-5T	ASB-5T	7,180	2,770	1,100	1	15
ASM-6T	ASB-6T	8,550	3,570	1,660	1	15
ASM-7T	ASB-7T	12,000	4,800	1,850	1	15
ASM-8T	ASB-8T	19,500	7,680	2,040	1	15
ASM-10T	ASB-10T	21,900	9,180	2,430	1	15
ASM-12T	ASB-12T	29,300	11,600	2,810	1	15
ASM-14T	ASB-14T	34,500	13,100	3,320	1	24
ASM-16T	ASB-16T	80,300	30,400	4,340	1	24

Temperature Range: 65°F to + 325°F

*No load rotational breakaway torque can be varied to meet specific application requirements.

Add Letter "K" to prefix to designate keyway, Ex. : ASMK 6T.

As applicable, keyway will conform to SAE AS81935/3 or NAS 559.

All threads are rolled after heat treatment, and conform to UNJF 3A per AS 8879.

AT 3200 Bearing Liner System is qualified for procurement under SAE AS81820.

Rod End Bearings listed are manufactured to conform to the dimensions, materials and configurations of SAE AS81935/1, and are approved for procurement under this specification.

ASW-T & ASG-T FEMALE ROD ENDS

High Strength – Aerospace Series SAE-AS81935/2 (Right Hand) & SAE-AS81935/2 (Left Hand)



Body - 4340 Alloy steel (AMS-S-5000), heat treated, cadmium plated.

Ball - 440C stainless steel (AMS 5630), heat treated.

Race - 17-4 PH stainless steel (AMS 5643), heat treated.

Liner - AT 3200 bearing liner, permanently bonded to race I.D., qualified to SAE-AS81820.

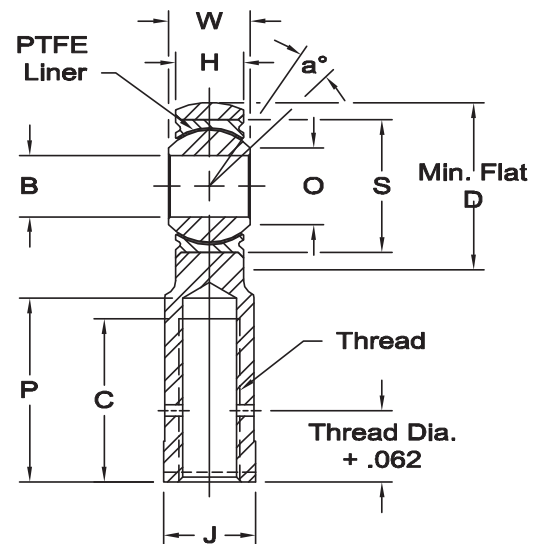
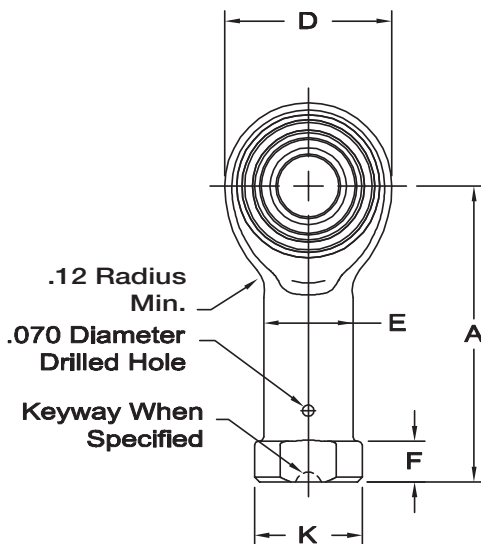

TABLE I

ROD END NO.		DIMENSIONS IN INCHES															a°	Approx. Brg. Wt. Lbs.
Right Hand	Left Hand	B + .0000 - .0005	W + .000 - .002	H ± .005	A ± .010	D ± .010	O Min.	S Max. Housing I.D.	E ± .010	K Ref. Dia.	J + .002 - .010	F + .010 - .062	Ball Dia. Ref.	P Max.	C Min.	Thread UNJF-3B	Misalign. Angle	
ASW-3T	ASG-3T	.1900	.437	.337	1.375	.806	.300	.6250	.422	.500	.437	.188	.531	.875	.750	5/16 24	15	.080
ASW-4T	ASG-4T	.2500	.437	.337	1.469	.806	.300	.6250	.422	.500	.437	.188	.531	.875	.750	5/16 24	15	.084
ASW-5T	ASG-5T	.3125	.437	.327	1.625	.900	.360	.6875	.485	.580	.500	.250	.593	1.000	.875	3/8 24	14	.102
ASW-6T	ASG-6T	.3750	.500	.416	1.812	1.025	.470	.8125	.547	.660	.562	.250	.687	1.125	1.000	3/8 24	8	.161
ASW-7T	ASG-7T	.4375	.562	.452	2.000	1.150	.540	.9062	.610	.720	.625	.250	.781	1.250	1.125	7/16 20	10	.212
ASW-8T	ASG-8T	.5000	.625	.515	2.250	1.337	.610	1.0000	.735	.880	.750	.250	.875	1.375	1.250	1/2 20	9	.325
ASW-10T	ASG-10T	.6250	.750	.577	2.500	1.525	.750	1.1875	.860	1.020	.875	.375	1.062	1.500	1.375	5/8 18	12	.481
ASW-12T	ASG-12T	.7500	.875	.640	2.875	1.775	.850	1.3750	.985	1.160	1.000	.375	1.250	1.750	1.625	3/4 16	13	.673
ASW-14T	ASG-14T	.8750	.875	.765	3.375	2.025	1.000	1.6250	1.110	1.300	1.125	.500	1.375	2.062	1.875	7/8 14	6	.959
ASW-16T	ASG-16T	1.0000	1.375	1.015	4.125	2.775	1.270	2.1250	1.688	2.020	1.750	.563	1.875	2.312	2.125	1 1/4 12	12	2.717

TABLE II

ROD END NO.		Ultimate Radial Static Load Lbs.	Fatigue Load Lbs.	Axial Proof Load Lbs.	No Load Rotational Breakaway Torque* In-Lbs.	
Right Hand	Left Hand				Min.	Max.
ASW-3T	ASG-3T	2,360	1,470	1,000	.5	6
ASW-4T	ASG-4T	4,860	2,380	1,000	.5	6
ASW-5T	ASG-5T	7,180	3,020	1,100	1	15
ASW-6T	ASG-6T	8,550	3,570	1,660	1	15
ASW-7T	ASG-7T	12,000	4,800	1,850	1	15
ASW-8T	ASG-8T	19,500	8,260	2,040	1	15
ASW-10T	ASG-10T	21,900	9,180	2,430	1	15
ASW-12T	ASG-12T	29,300	11,600	2,810	1	15
ASW-14T	ASG-14T	34,500	13,100	3,320	1	24
ASW-16T	ASG-16T	80,300	30,400	4,340	1	24

Temperature Range: 65°F to + 325°F

*No load rotational breakaway torque can be varied to meet specific application requirements.

Add Letter "K" to prefix to designate keyway, Ex. : ASWK 6T.

As applicable, keyway will conform to SAE AS81935/3 or NAS 559.

All threads conform to UNJF 3B per AS 8879.

AT 3200 Bearing Liner System is qualified for procurement under SAE AS81820.

Rod End Bearings listed are manufactured to conform to the dimensions, materials and configurations of SAE AS81935/2, and are approved for procurement under this specification.



ANC-T & ANC-TG SPHERICAL BEARINGS

Narrow – Aerospace Series SAE-AS14101 and SAE-AS14104



GROOVED SERIES

PLAIN SERIES

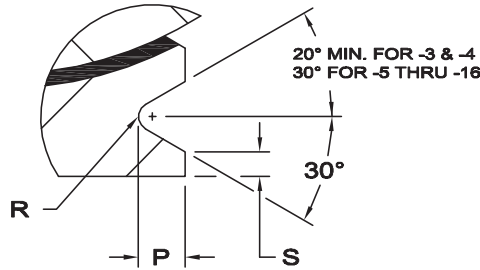
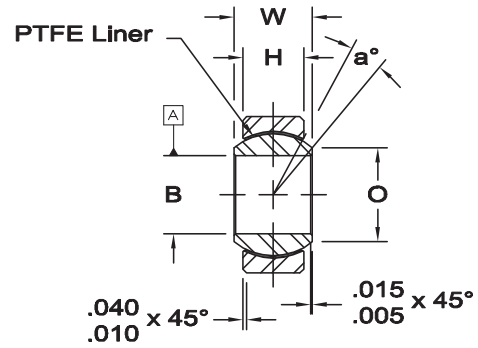
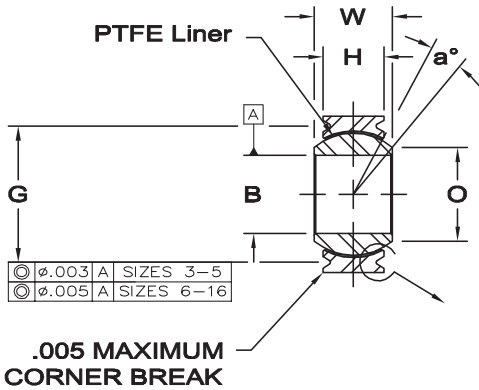
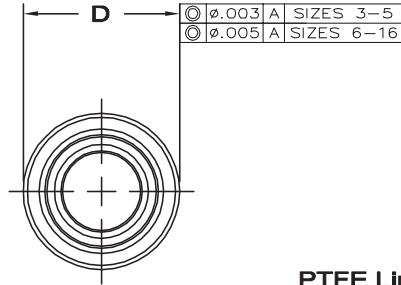

Ball - 440C stainless steel (AMS 5630), heat treated.

Race - 17-4 PH stainless steel (AMS 5643), heat treated.

Liner - AT 3200 bearing liner, permanently bonded to race I.D., qualified to SAE-AS81820.

Temperature Range: 65°F to + 325°F

*No load rotational breakaway torque can be varied to meet specific application requirements.

AT 3200 Bearing Liner System is qualified for procurement under SAE AS81820.

Bearings listed are manufactured to conform to the dimensions, materials and configurations of Military Specifications SAE AS14101 (grooved) and SAE AS14104 (plain), and are approved for procurement under this specification.

BEARING NO.		DIMENSIONS IN INCHES										a°	Static Limit Load		Oscillat- ing Load Lbs.	No Load Rotational Breakaway Torque* In-Lbs.	Approx. Brg. Wt. Lb	
Grooved	Plain	B	D	W	H	O	P	S	G	R	Ball Dia. Ref.		Radial Lbs.	Axial Lbs.				
ANC-3TG	ANC-3T	.1900	.5625	.281	.218	.293	.025	.010	.500	.010	.406	10	3,975	150	1,500	0.25	5.0	.020
ANC-4TG	ANC-4T	.2500	.6562	.343	.250	.364	.025	.010	.594	.010	.500	10	6,040	430	3,320	0.25	5.0	.020
ANC-5TG	ANC-5T	.3125	.7500	.375	.281	.419	.035	.020	.650	.010	.562	10	8,750	700	5,460	0.25	8.0	.030
ANC-6TG	ANC-6T	.3750	.8125	.406	.312	.475	.035	.020	.712	.015	.625	9	10,540	1,100	6,600	0.25	8.0	.040
ANC-7TG	ANC-7T	.4375	.9062	.437	.343	.530	.035	.020	.806	.015	.687	8	13,200	1,400	8,050	0.25	8.0	.050
ANC-8TG	ANC-8T	.5000	1.0000	.500	.390	.600	.055	.020	.876	.015	.781	8	17,900	2,100	10,400	0.25	8.0	.070
ANC-9TG	ANC-9T	.5625	1.0937	.562	.437	.670	.055	.020	.970	.015	.875	8	23,200	3,680	13,000	0.25	8.0	.090
ANC-10TG	ANC-10T	.6250	1.1875	.625	.500	.739	.055	.020	1.063	.015	.968	8	30,500	4,720	16,450	0.25	8.0	.120
ANC-12TG	ANC-12T	.7500	1.4375	.750	.593	.920	.055	.020	1.313	.015	1.187	8	46,400	6,750	23,600	0.25	8.0	.210
ANC-14TG	ANC-14T	.8750	1.5625	.875	.703	.980	.055	.020	1.438	.015	1.312	8	62,200	9,350	30,250	0.25	12.0	.270
ANC-16TG	ANC-16T	1.0000	1.7500	1.000	.797	1.118	.055	.020	1.626	.015	1.500	9	82,200	12,160	38,000	0.25	12.0	.390

AWC-T & AWC-TG SPHERICAL BEARINGS

Wide – Aerospace Series SAE-AS14102 and SAE-AS14103



GROOVED SERIES

PLAIN SERIES

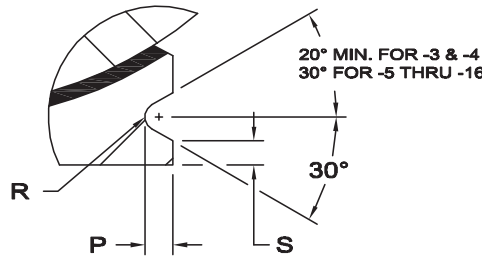
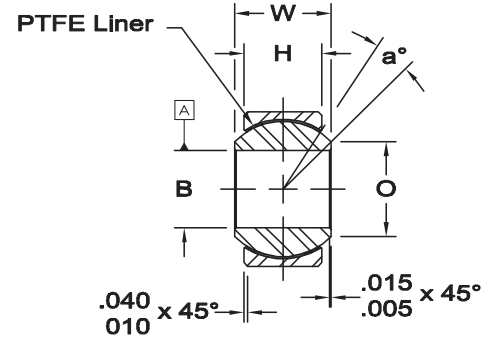
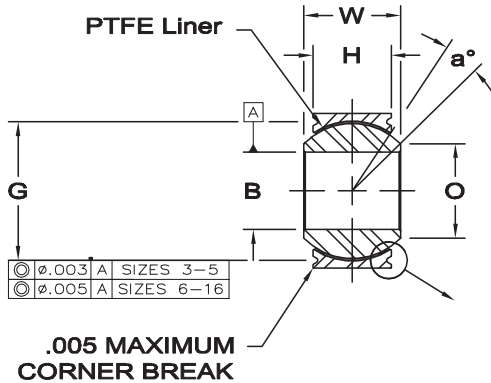
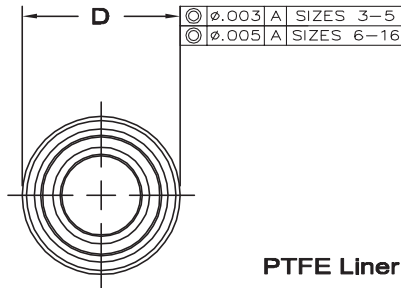

Ball - 440C stainless steel (AMS 5630), heat treated.

Race - 17-4 PH stainless steel (AMS 5643), heat treated.

Liner - AT 3200 bearing liner, permanently bonded to race I.D., qualified to SAE-AS81820.

Temperature Range: 65°F to + 325°F

*No load rotational breakaway torque can be varied to meet specific application requirements.

AT 3200 Bearing Liner System is qualified for procurement under SAE AS81820.

Bearings listed are manufactured to conform to the dimensions, materials and configurations of Military Specifications SAE AS14103 (grooved) and SAE AS14102 (plain), and are approved for procurement under this specification.

BEARING NO.		DIMENSIONS IN INCHES										a°	Static Limit Load		Oscillat-ing Load Lbs.	No Load Rotational Breakaway Torque* In-Lbs.	Approx. Brg. Wt. Lb	
Grooved	Plain	B	D	W	H	O	P	S	G	R	Ball Dia. Ref.		Radial Lbs.	Axial Lbs.				
AWC-3TG	AWC-3T	.1900	.6250	.437	.327	.300	.025	.010	.563	.010	.531	15	2,500	1,770	4,900	0.25	5.0	.031
AWC-4TG	AWC-4T	.2500	.6250	.437	.327	.300	.025	.010	.563	.010	.531	15	5,500	1,770	4,900	0.25	5.0	.031
AWC-5TG	AWC-5T	.3125	.6875	.437	.317	.360	.025	.010	.625	.010	.593	14	9,400	1,640	6,050	0.25	8.0	.035
AWC-6TG	AWC-6T	.3750	.8125	.500	.406	.466	.035	.020	.712	.015	.687	8	13,700	2,630	8,310	0.25	8.0	.060
AWC-7TG	AWC-7T	.4375	.9375	.562	.442	.537	.035	.020	.837	.015	.781	10	20,700	3,650	11,750	0.25	8.0	.080
AWC-8TG	AWC-8T	.5000	1.0000	.625	.505	.607	.035	.020	.900	.015	.875	9	21,400	4,970	14,950	0.25	8.0	.100
AWC-9TG	AWC-9T	.5625	1.1250	.687	.536	.721	.035	.020	1.025	.015	1.000	10	26,600	5,370	18,100	0.25	8.0	.135
AWC-10TG	AWC-10T	.6250	1.1875	.750	.567	.747	.035	.020	1.087	.015	1.062	12	29,000	6,130	20,250	0.25	8.0	.160
AWC-12TG	AWC-12T	.7500	1.3750	.875	.630	.845	.055	.020	1.251	.015	1.250	13	37,000	7,730	26,200	0.25	8.0	.240
AWC-14TG	AWC-14T	.8750	1.6250	.875	.755	.995	.055	.020	1.501	.015	1.375	6	65,200	10,800	33,600	0.25	12.0	.350
AWC-16TG	AWC-16T	1.0000	2.1250	1.375	1.005	1.269	.055	.020	2.001	.015	1.875	12	104,000	19,300	56,250	0.25	12.0	.970



GMM-M & GMB-M SERIES MALE ROD ENDS

General Aviation – Precision

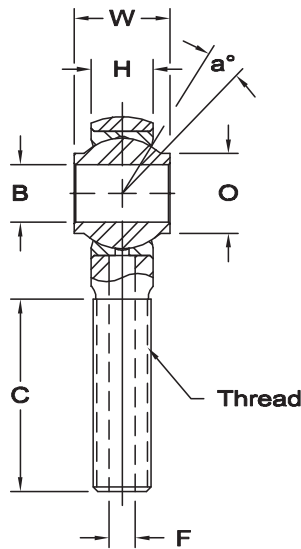
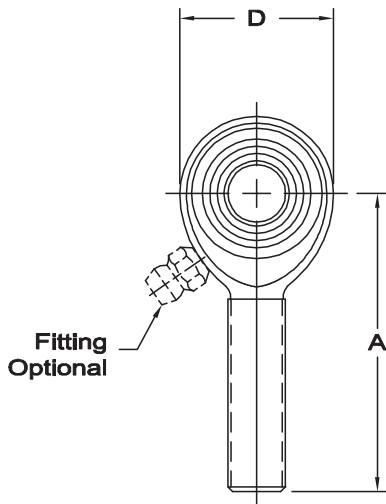

DETAIL
"A"

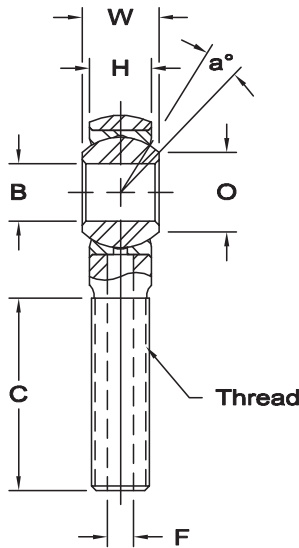
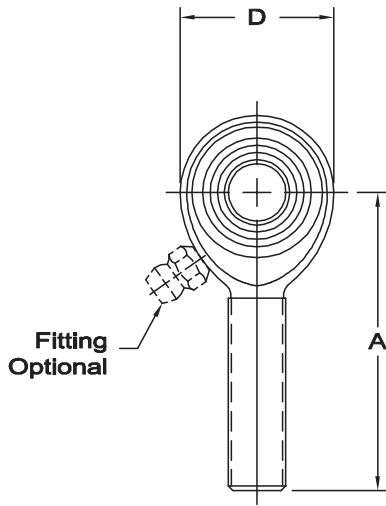

DETAIL
"B"



Body - Carbon steel, protective coated for corrosion resistance.

Race - Carbon steel, protective coated for corrosion resistance.

Ball - Alloy steel, heat treated, hard chrome plated.

Load ratings apply only to rod ends without grease fittings. For load ratings with fittings, please contact our engineering department.

Units are supplied without grease fittings. When a grease fitting is required, specify by adding suffix as designated.

Z Zerk type fitting

Ex: GMM 3MZ 470

F Flush type fitting

Ex: GMM 3MF 470

Notes - Units are magnetic particle inspected after assembly.

BEARING NO.		DIMENSIONS IN INCHES											a° Misalign. Angle	Ultimate Radial Static Load Capacity Lbs.	Approx. Brg. Wt. Lbs.
Right Hand	Left Hand	Ball Shoulder Configuration	B + .0015 - .0005	W + .000 - .005	H ±.005	A ±.015	D ±.010	O Shoulder Dia. Ref.	Ball Dia. Ref.	C Min.	F Drilled Hole Dia ref	Thread UNF-3A			
GMM-3M-470	GMB-3M-470	See Detail "A"	.1900	.437	.281	1.562	.750	.315	.500	.969		1/4 28	17	2,158	.05
GMM-3M-570	GMB-3M-570	See Detail "A"	.1900	.437	.328	1.375	.875	.315	.500	.750	.113	5/16 24	10	2,823	.07
GMM-3M-670	GMB-3M-670	See Detail "A"	.1900	.437	.328	1.375	.750	.315	.500	.750	.113	3/8 24	10	2,850	.08
GMM-3M-680	GMB-3M-680	See Detail "B"	.1900	.500	.375	1.812	.833	.319	.593	1.062	.136	3/8 24	18	3,269	.09
GMM-4M-470	GMB-4M-470	See Detail "B"	.2500	.437	.304	1.562	.812	.353	.562	.969		1/4 28	18	2,158	.07
GMM-4M-675	GMB-4M-675	See Detail "B"	.2500	.484	.335	2.312	.875	.395	.625	1.500	.136	3/8 24	18	3,160	.11
GMM-4M-680	GMB-4M-680	See Detail "B"	.2500	.500	.335	2.062	.875	.375	.625	1.500	.159	3/8 24	10.5	2,985	.10

GMW-M & GMG-M SERIES FEMALE ROD ENDS

General Aviation – Precision



**DETAIL
"A"**

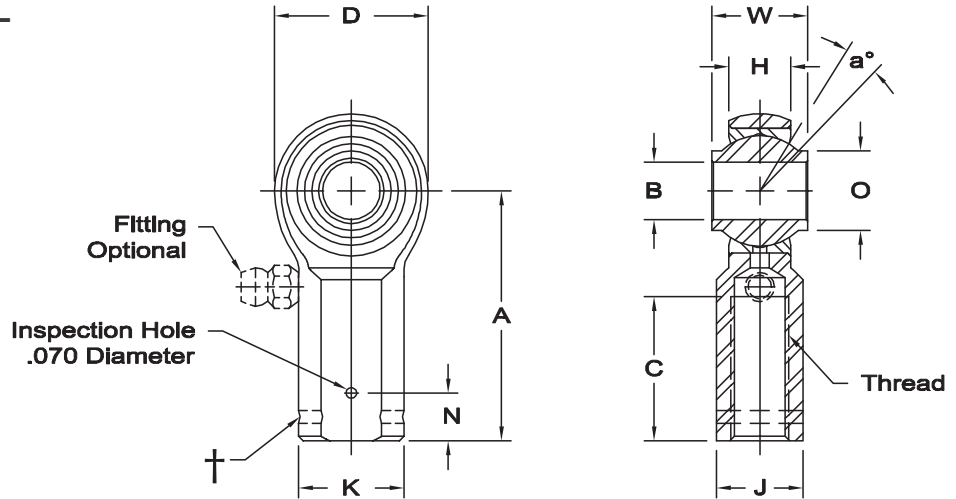

**DETAIL
"B"**

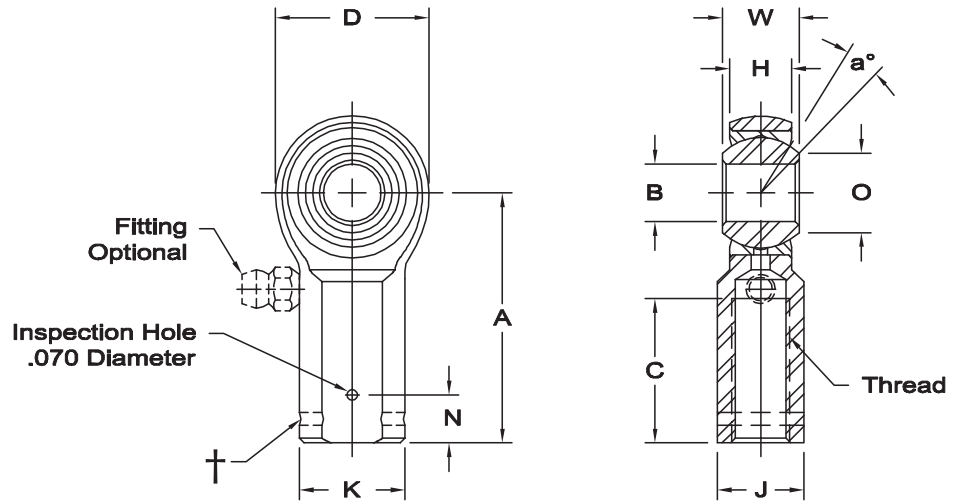

Body - Carbon steel, protective coated for corrosion resistance.

Race - Carbon steel, protective coated for corrosion resistance.

Ball - Alloy steel, heat treated, hard chrome plated.

Notes - Units are magnetic particle inspected after assembly.

† Left hand units identification groove near end of shank.

Units are supplied without grease fittings. When a grease fitting is required, specify by adding suffix as designated.

Z Zerk type fitting

Ex: GMW 3MZ 470

F Flush type fitting

Ex: GMW 3MF 470

Load ratings apply only to rod ends without grease fittings. For load ratings with fittings, please consult our engineering department.

BEARING NO.		DIMENSIONS IN INCHES													a° Misalign. Angle	Ultimate Radial Static Load Capacity Lbs.	Approx. Brg. Wt. Lbs.
Right Hand	Left Hand†	Ball Shoulder Configuration	B +.0015 -.0005	W +.000 -.005	H ±.005	A ±.015	D ±.010	K ±.010	J ±.010	N ±.005	O Shoulder Dia. Ref.	Ball Dia. Ref.	C +.062 -.031	Thread UNF- 3B			
GMW-3M-470	GMG-3M-470	See Detail "A"	.1900	.437	.328	1.375	.750	.468	.375	.312	.315	.500	.750	1/4 28	10	2,881	.06
GMW-3M-471	GMG-3M-471	See Detail "A"	.1900	.437	.328	1.062	.750	.375			.315	.500	.437	1/4 28	10	2,881	.05
GMW-3M-480	GMG-3M-480	See Detail "A"	.1900	.500	.375	1.375	.812	.468	.375	.312	.312	.562	.750	1/4 28	15	3,152	.08
GMW-3M-570	GMG-3M-570	See Detail "A"	.1900	.437	.328	1.375	.750	.500	.437	.312	.315	.500	.750	5/16 24	10	2,881	.07
GMW-4M-470	GMG-4M-470	See Detail "B"	.2500	.437	.304	1.375	.812	.468	.375	.312	.353	.562	.750	1/4 28	18	2,950	.08
GMW-4M-595	GMG-4M-595	See Detail "A"	.2500	.593	.406	1.469	.938	.500	.437	.312	.485	.687	.844	5/16 24	10	3,359	.10



INSTALLATION OF SPHERICAL BEARING

Figure 1

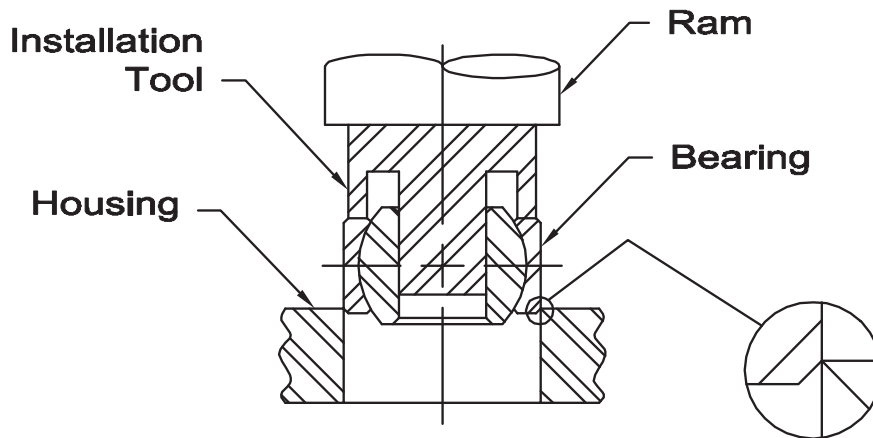

SPHERICAL BEARING INSTALLATION

Proper installation of the bearing is important to prevent bearing failure as well as housing damage. Under no circumstances should a tool that induces shock or impact to the bearing be used. The use of an arbor press or hydraulic press is recommended. A tool as shown above (Figure 1) is advised. All force is to be applied on the bearing race face (not on ball). A lead chamfer or radius on the bearing and/or housing is vital.

HOUSING CHAMFER - GROOVED BEARINGS

CHAMFER FOR GROOVE TYPES	
GROOVE TYPE A	.020 ± .005
GROOVE TYPE B	.030 ± .005
GROOVE TYPE C	.050 ± .005

Chamfer
See Chart

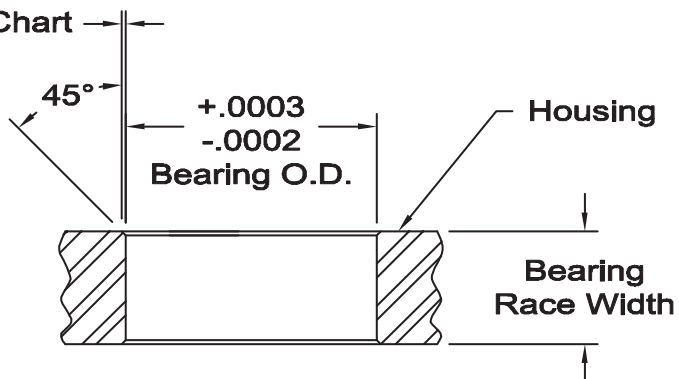

STAKING GROOVE TYPES

Groove Type "A"

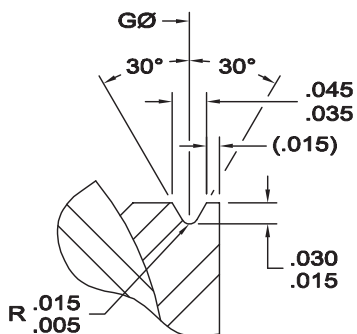

Groove Type "B"

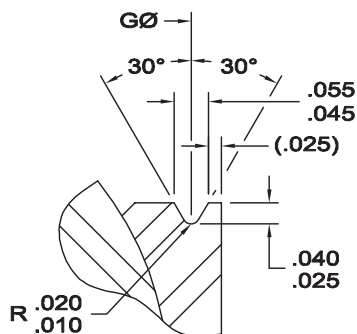

Groove Type "C"

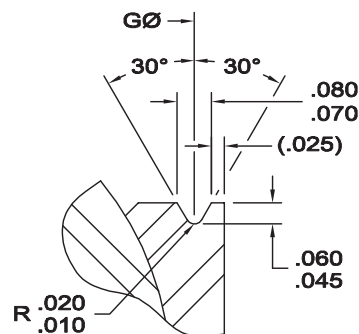
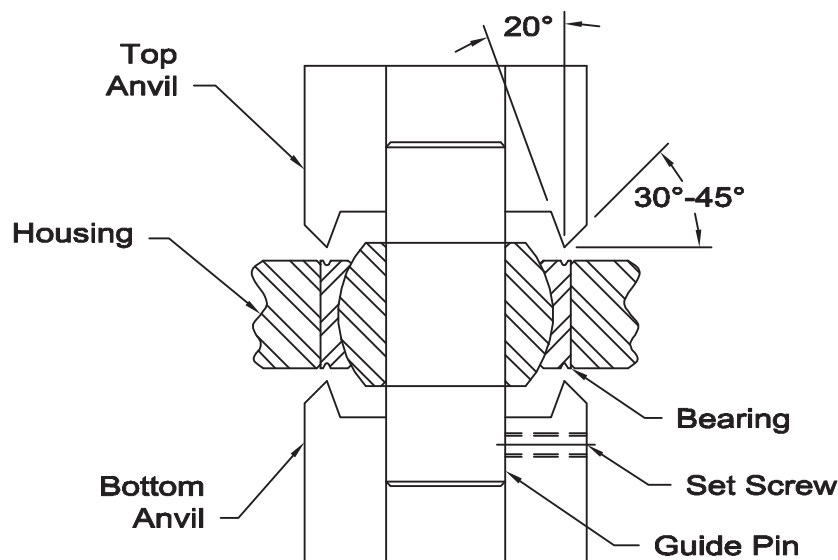

Figure 2



SPHERICAL BEARING INSTALLATION

The bearings have grooves in each side of the bearing race face, leaving a small lip. Staking tools (as shown above in Figure 2) are then used to stake the lip over the chamfer edges of the housing. A typical arrangement consists of two identical anvils and one guide pin which is secured by a set screw in the bottom anvil.

PROCEDURES

1. Install bearing into housing as shown in Figure 1 (pg. 76) and position bearing symmetrical about housing centerline.
2. Align bearing with staking tool and guide pin as shown in Figure 2.
3. A trial stake assembly should be made to determine staking force necessary to meet thrust load requirements. Proper staking force is required because excessive pressure could result in bearing distortion along with life.
4. Pressure established by trial assembly is to be applied. After first stake is completed rotate assembly 90° and re-apply. Repeat operation through a minimum of three rotations to insure 360° uniformity of stake.
5. After staking, a slight gap may exist between race lip and housing chamfer. This slight gap (shown below) may not be cause for rejection if bearing meets or exceeds thrust loads.

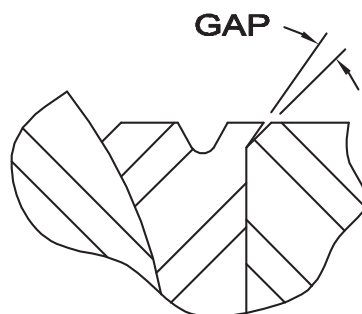



REFERENCE

Special Size Race Car Parts

Parts commonly used in the race car industry, along with common part number references. While not cataloged, many of these parts are stocked. Check with dealer or factory for availability.

Aurora Part #	Common Part #	B	H	W	D	A	Thread	Description / Note
AM 4T 9	RC04	0.2500	0.281	0.312	0.7500	1.562	5/16 24	
AM 6T 6	2057P	0.3750	0.406	0.500	1.0000	1.938	1/2 20	
AM 6T 7		0.3750	0.500	0.625	1.3120	2.438	5/8 18	
AM 6T 15	1865P	0.3750	0.500	0.625	1.3120	2.438	1/2 20	
AM 12 2		0.7500	0.875	0.875	1.7500	2.875	3/4 16	Solid rod eye
AM 14T 8		0.8750	0.765	0.875	2.3250	3.500	1 14	
AM 14T 70		0.8750	0.765	0.875	2.000	3.375	7/8 14	Heat treated race
CM 12 12		0.7570	0.593	0.875	1.7500	2.875	3/4 16	
COM 8T 7	21CNZ081	0.5000	0.375	0.437	0.8750			Heat treated race
COM 8T 18	3087P	0.5000	0.390	0.750	1.1875			
COM 8T 20	1243	0.5000	0.375	0.437	0.8750			Mild steel race
COM 8T 45		0.5000	0.390	1.000	1.0000			Drag Shocks
COM 10T 18	2280P	0.6250	0.630	0.875	1.3750			
HAB 5TG 3	ABYT 5V	0.3125	0.255	0.625	0.6875			
HXAM 8T 8		0.5000	0.411	0.937	1.5250	2.625	1/2 20	High Misalignment
LCOM 10T	LS10, RS10	0.6250	0.687	0.875	1.5625			
PRXM 7T 1		0.4375	0.452	0.562	1.2450	2.500	1/2 20	
PWB 8T 3	RWR08D/E	0.5000	0.500	0.750	1.1250			
RXAM 8T 3		0.5000	0.562	0.750	1.7500	2.875	3/4 16	
RAM 16T 1		1.0000	1.000	1.375	2.7750	4.125	1 14	100,643 lb. RSLC
RAM 16T 3		1.0000	1.000	1.375	2.7750	4.125	1 1/4 12	100,643 lb. RSLC
XAM 6T 1	1560P	0.3750	0.406	0.500	1.3120	2.438	1/2 20	
XAM 8T 2		0.5000	0.562	0.750	1.7500	2.875	3/4 16	
XAM 8T 5	MNR08U	0.5000	0.406	0.500	1.3120	2.438	1/2 20	
XCM 8		0.5000	0.453	0.625	1.5000	2.625	5/8 18	2 piece. Lined:VXCM 8

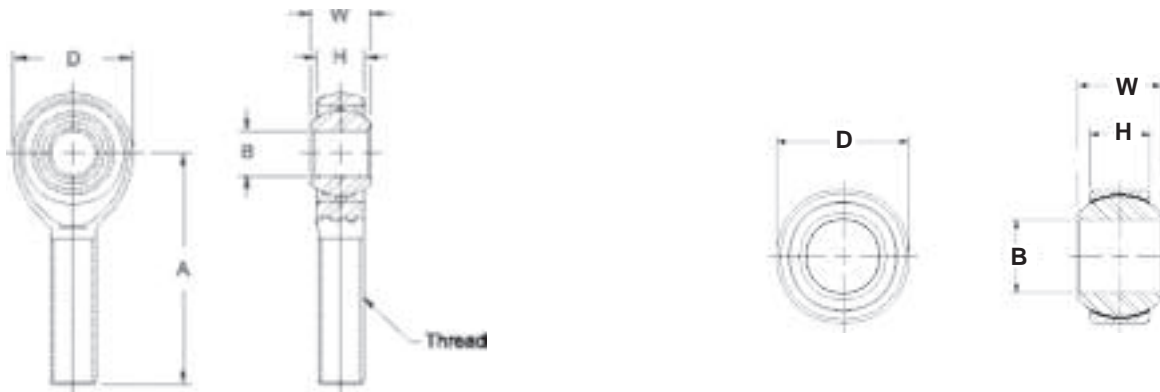

Note: Dimensions are for reference only, and may not fully reflect actual part specifications. Check catalog or factory for related series material specifications, tolerances, etc.



REFERENCE

Inch / Metric Conversion Table



Most commonly used conversions in **Bold**.

INCH		MM	INCH		MM	INCH		MM	INCH		MM
FRACT.	DEC.		FRACT.	DEC.		FRACT.	DEC.		FRACT.	DEC.	
	0.0004	0.001	17/64	0.2656	6.746		0.6693	17.0		1.3780	35.0
	0.0039	0.01		0.2756	7.0	43/64	0.6719	17.066		1.4173	36.0
	0.0010	0.025	9/32	0.2812	7.1437	11/16	0.6875	17.4625	1 1/2	1.5000	38.1
	0.0020	0.051	19/64	0.2969	7.5406	45/64	0.7031	17.859		1.5354	39.0
	0.0030	0.0762	5/16	0.3125	7.9375		0.7086	18.0		1.5748	40.0
	0.00394	0.1		0.3150	8.0	23/32	0.7187	18.256		1.6535	42.0
	0.0050	0.1270	21/64	0.3281	8.334	47/64	0.7334	18.653	1 3/4	1.7500	44.45
	0.00984	0.25	11/32	0.3437	8.731		0.7480	19.0		1.7717	45.0
	0.0100	0.254		0.3543	9.0	3/4	0.7500	19.05		1.8898	48.0
1/64	0.0156	0.396	23/64	0.3594	9.1281	49/64	0.7656	19.446		1.9685	50.0
1/32	0.0312	0.793	3/8	0.3750	9.525	25/32	0.7812	19.843	2	2.0000	50.8
	0.03937	1.0	25/64	0.3906	9.9219		0.7874	20.0		2.0472	52.0
3/64	0.0469	1.191		0.3937	10.0	51/64	0.7969	20.240		2.1654	55.0
	0.0591	1.5	13/32	0.4062	10.318	13/16	0.8125	20.6375		2.2047	56.0
1/16	0.0625	1.5875	27/64	0.4219	10.716		0.8268	21.0	2 1/4	2.2500	57.15
5/64	0.0781	1.984		0.4331	11.0	53/64	0.8281	21.034		2.3622	60.0
	0.0787	2.0	7/16	0.4375	11.1125	27/32	0.8437	21.431	2 1/2	2.5000	63.5
3/32	0.0937	2.381	29/64	0.4531	11.509	55/64	0.8594	21.828		2.5197	64.0
	0.0984	2.5	15/32	0.4687	11.906		0.8661	22.0	2 3/4	2.7500	69.85
	0.1000	2.54		0.4724	12.0	7/8	0.8750	22.225		2.8346	72.0
7/64	0.1094	2.778	31/64	0.4844	12.303	57/64	0.8906	22.621		2.9528	75.0
	0.1181	3.0	1/2	0.5000	12.7		0.9055	23.0	3	3.0000	76.2
1/8	0.1250	3.175		0.5118	13.0	29/32	0.9062	23.018		3.1496	80.0
	0.1387	3.5	33/64	0.5156	13.096	59/64	0.9219	23.416	3 1/4	3.2500	82.55
9/64	0.1406	3.571	17/32	0.5312	13.493	15/16	0.9375	23.8125	3 1/2	3.5000	88.9
5/32	0.1562	3.968	35/64	0.5469	13.891		0.9449	24.0		3.5433	90.0
	0.1575	4.0		0.5512	14.0	61/64	0.9531	24.209	3 3/4	3.7500	95.25
11/64	0.1719	4.366	9/16	0.5625	14.2875	31/32	0.9687	24.606		3.9370	100.0
	0.1772	4.5	37/64	0.5781	14.684		0.9843	25.0	4	4.0000	101.6
3/16	0.1875	4.7625		0.5906	15.0	63/64	0.9844	25.003	4 1/4	4.2500	107.95
	0.1969	5.0	19/32	0.5937	15.081	1	1.0000	25.4		4.3307	110.0
13/64	0.2031	5.159	39/64	0.6094	15.478		1.0630	27.0	4 1/2	4.5000	114.3
7/32	0.2187	5.556	5/8	0.6250	15.875		1.1024	28.0		4.7244	120.0
15/64	0.2344	5.953		0.6299	16.0		1.1811	30.0	4 3/4	4.7500	120.65
	0.2362	6.0	41/64	0.6406	16.271	1 1/4	1.2500	31.75	5	5.0000	127.0
1/4	0.2500	6.35	21/32	0.6562	16.668		1.2992	33.0	5 1/2	5.5000	139.7

INCH/METRIC CONVERSION FACTORS

Inches	x 25.4	= Millimeters	Pounds	x .4536	= Kilograms	Pounds(Force)x 4.448	= Newtons
Millimeters	x .03937	= Inches	Kilograms	x 2.2046	= Pounds	Newtons	x .2248 = Pounds(Force)
Sq. Inches	x 6.4515	= Sq. Centimeters	Lbs. per In. ²	x .0703	= kg per cm ²	Temperature Conversion (Approximate)	
Sq. Centimeters	x .155	= Sq. Inches	kg per cm ²	x 14.2231	= Lbs. per In. ²	Degrees C = (Degrees F - 32) (.5556)	
						Degrees F = (Degrees C) (1.8) + 32	



REFERENCE

Engineering Information

TAP DRILL SIZES FOR INCH THREADS			
Screw Thread		Commercial Tap Drills	
Thread size	Root Dia.	Size or Number	Decimal Equiv.
6-32	0.0834	36	0.1065
10-32	0.1469	22	0.1570
1/4-28	0.2036	3	0.2130
5/16-24	0.2584	I	0.2720
3/8-24	0.3209	Q	0.3320
7/16-20	0.3726	25/64	0.3906
1/2-13	0.4001	27/64	0.4219
1/2-20	0.4351	29/64	0.4531
5/8-11	0.5069	17/32	0.5312
5/8-18	0.5528	37/64	0.5781
3/4-16	0.6688	11/16	0.6875
7/8-14	0.7822	13/16	0.8125
1-12	0.8918	59/64	0.9219
1-14	0.9072	15/16	0.9375
1 1/4-12	1.1418	1 11/64	1.1719
1 1/2-12	1.3918	1 27/64	1.4219
1 3/4-12	1.6050	1 21/32	1.6563
2-12	1.8557	1 29/32	1.9063

TAP DRILL SIZE METRIC THREADS	
THREAD SIZE/TAP	METRIC DRILL SIZE
M3 X 0.5	2.50
M5 X 0.8	4.20
M6 X 1.0	5.00
M8 X 1.25	6.80
M10 X 1.5	8.50
M12 X 1.75	10.20
M14 X 2.0	12.00
M16 X 2.0	14.00
M18 X 1.5	16.50
M20 X 1.5	18.50
M22 X 1.5	20.5
M24 X 2.0	22.0
M30 X 2.0	28.0

The tables above are to be used as guides only. Consult the appropriate reference to determine best size based on fit requirements, materials used, etc.

STEEL DESIGNATION CROSS REFERENCE TABLE

USA	BRITAIN	FRANCE	GERMANY	ITALY	JAPAN
AISI	B.S.	AFNOR	DIN	UNI	JIS
1015	080 M 15	XC 15	Ck 15	C 15	S 15 C
1018	080 A 17		C 16.8		
1022	120 M 19	20 M 5	20 Mn 5	G 22 Mn 3	SMnC 420
1114	212 M 44				SUM 43
1215	240 M 07	S 300	9 SMn 36	CF 9 Mn 36	SUM 23
4130	1717 CDS 110	25 CD 4	25 CrMo 4	25 CrMo 4	SCM 420
4140	708 M 40	42 CD 4 TS	41 CrMo 4	41 CrMo	SCM 440
4340	817 M 40	35 NCD 6	24 CrNiMo 6	35 NiCrMo 6	SNCM 447
52100	534 A 99	100 C 6	100 Cr 6	100 Cr 6	SUJ 2
303	303 S 21	Z 10 CNF 18.09	X 10 CrNiS 18 9	X 10 CrNiS 1809	SUS 303
410	410 S 21	Z 3 C 14	X7 Cr 14	X 12Cr 13	SUS 51
440C		Z 100 CD 17	X 105 CrMo 17		SUS 57
17-4		Z 5 CNU 17.4	X 5 CrNiCuNb 17 14		SUS 80

This table is to be used as a guide to assist in finding comparable metal designations only. True interchange can be determined only by comparing chemical composition, mechanical properties, and manufacturing technologies.



**EXCLUSIVE:
SPECIALLY DESIGNED
ROD ENDS AND LINKAGES**



Illustrated are a variety of special linkages and rod ends. Let us design specials to meet your specific applications.

**EXCLUSIVE:
2D AND 3D CAD DRAWINGS OF AURORA BEARING
ROD END AND SPHERICAL BEARINGS**

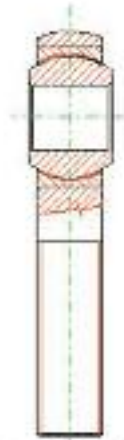

Cross section, MM-8T



3D model, MM-8T



Front view, MM-8T

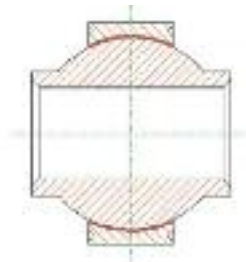

Cross section, HAB-6TG



3D model, HAB-6TG

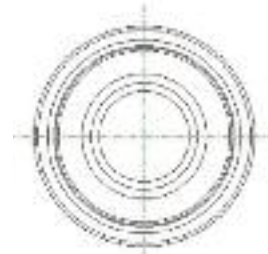

Front View, HAB-6TG