

Part Number: TCO-314 / TCO-814



Kit Contents

Item #	Quantity Reqd.	Description
1	2	Light Housings
2	2	Fog Light bezels
3	1	Switch Assembly
4	1	Fog Light Operation guide
5	1	Harness Bag

Hardware Bag Contents

Item #	Quantity Reqd.	Description
1	1	Wire harness
2	1	Switch harness
3	1	Relay box / module
4	25	8" Wire ties
5	4	Phillip head screws
6	1	Black T-Tap
7	1	High-beam headlight jumper wire
8	2	LED Connectors (for TCO-814)

Conflicts

- S Models

General Applicability

Models:

Recommended Tools

Safety Tools	
Safety Glasses	
Electrical Tape	
Installation Tools	
10mm Wrench	
Phillips Screw Driver	
Pliers	
Side Cutters	
Special Chemicals	
3M Silicon Sealant	

Mandatory

Legend

	STOP: Damage to the vehicle may occur. Do not proceed until process has been complied with.
	OPERATOR SAFETY: Use caution to avoid risk of injury
	CRITICAL PROCESS: Proceed with caution to ensure a quality installation.
	TOOLS & EQUIPMENT: This calls out the specific tools and equipment required for this process
	REVISION MARK: This mark highlights a change in installation with respect to previous issue.

Care must be taken when installing this accessory to ensure damage does not occur to the vehicle. The installation of this accessory should follow approved guidelines to ensure quality installation.

Preparation



Remove battery from vehicle



Installation

1. Route the 12v red wire from fog light harness through positive red terminal cover. Use wire ties to secure wire harness and fuse to the positive cable from battery (picture 1). Secure the ring terminal to the positive battery terminal.

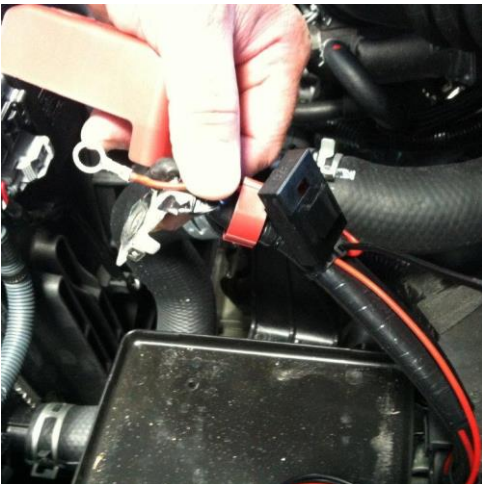

Picture 1

2. Attach the ring terminal with 2 black wires to the 10mm (ground) nut next to the battery (picture 2)

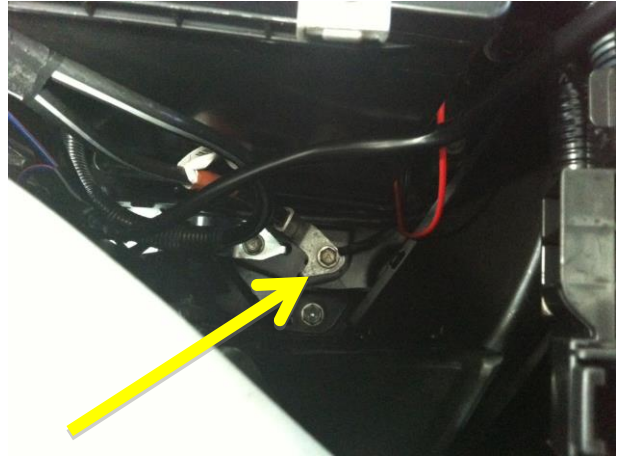

Picture 2

3. Secure excess wire to battery positive wire (picture 3)

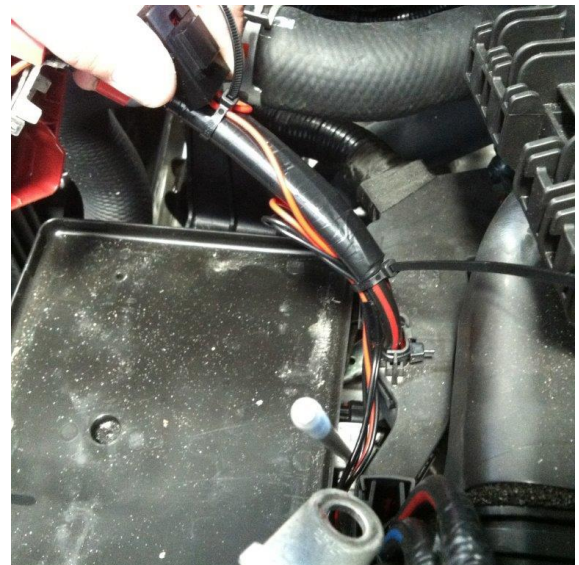

Picture 3

4. Route the fog light wire harness along the driver side from the battery towards the

bulkhead of the vehicle. Secure the wire harness with wire ties as needed (picture 4)



Picture 4

5. Locate the large vehicle harness grommet on the driver side. If accessible, cut the auxiliary wiring access nipple off the grommet or cut ¼" slit in grommet. Using fish tool Push the fog light wire harness through grommet. **Note:** Extra caution should be taken not to damage the connectors on the fog light harness or on the vehicle harness. Seal with 3M Silicone sealant (picture 5).



Picture 5

Vehicle Disassembly

6. Remove the driver's scuff plate, by disengaging the claws (picture 6)

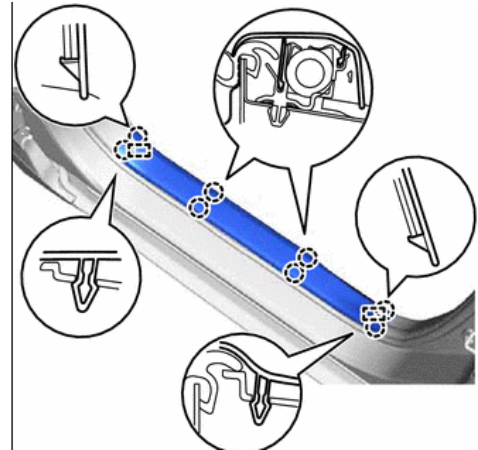

Picture 6

7. Remove the side kick panel by removing the clip (picture 7)

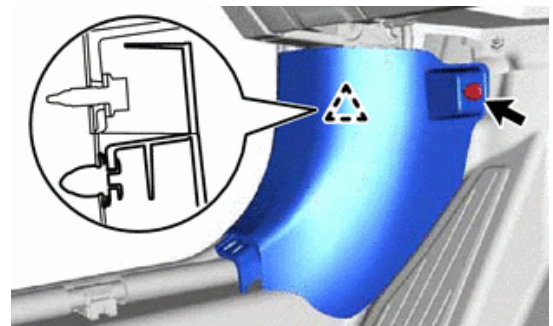

Picture 7

8. Remove side instrument panel. Using a pry tool, disengage the clips (picture 8)

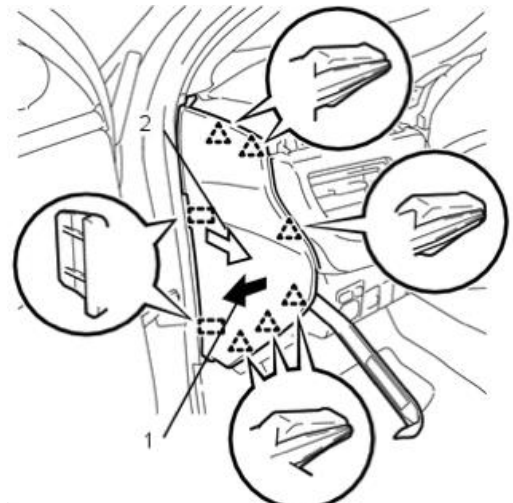

Picture 8

9. Remove left side switch panel: Remove switch knockout, then remove screw and claws securing panel (pictures 9 and 9A)

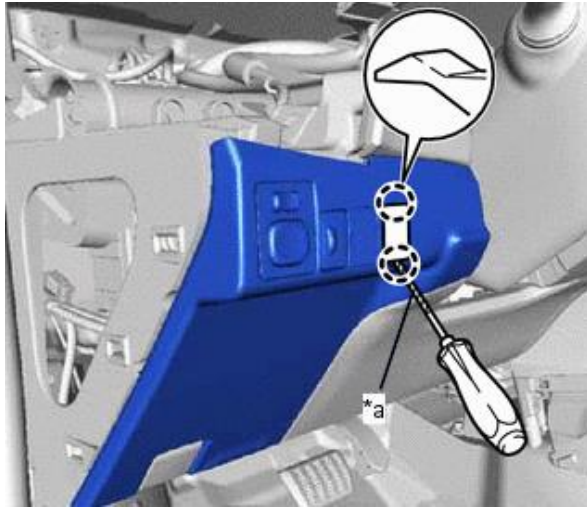

Picture 9

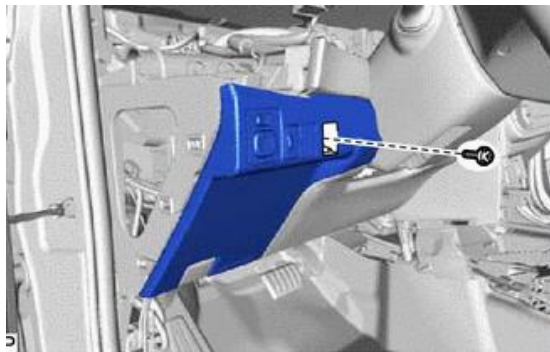

Picture 9A

10. Use an empty switch knock out on left panel, then mount switch into switch knock out (picture 10)



Picture 10

11. Locate the wires that were pushed through the grommet in step 5. It will be the grommet above the gas pedal. Route the wire harness above the gas pedal. Route the wire harness to reach the area on left of the steering wheel and tie wrap to factory harness (picture 11)



Picture 11

12. Push the supplied white connector into the white wire pin. Then connect the switch harness to the wire harness: 2 bullet connectors and one white connector (pic. 12)

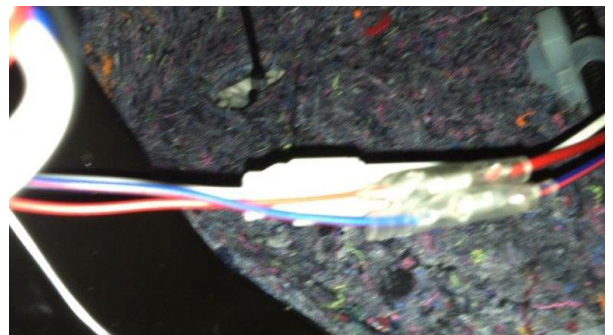

Picture 12

13. Install a black T-tap to the headlight circuit connector 3A pin 34, black wire. Connect the orange/black wire from fog light harness. Connector 3A is left of steering wheel at the main junction block (pictures 13 ~ 13C)

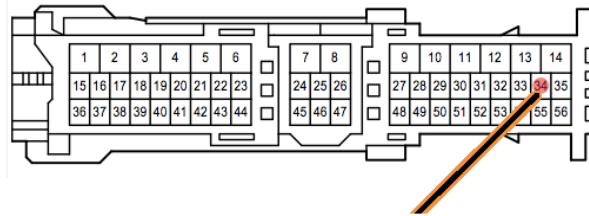
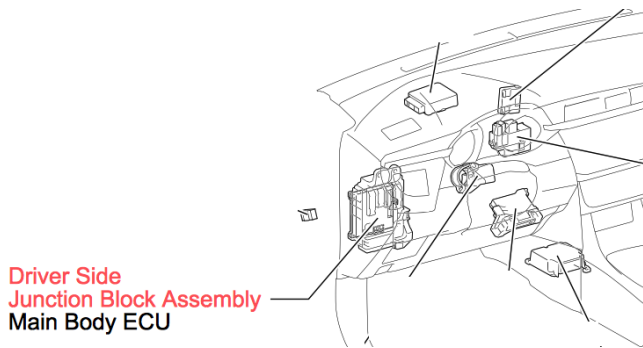

Orange-black wire from Fog Light harness to pin 34 (black wire)

Picture 13A Connector 3A, pin 34
Orange-Black to Pin 34, Black wire

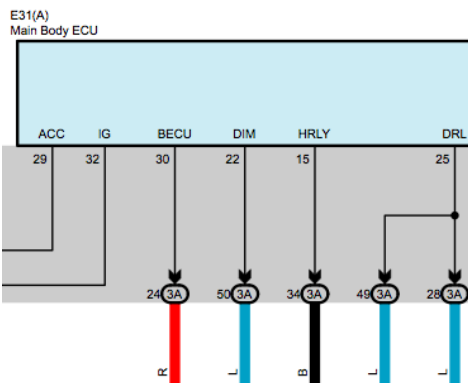

Picture 13C: Headlight circuit

- Secure black relay box and excess wire to main wire harness (picture 14).



- Secure black ground wire to ground point behind kick panel (picture 15).

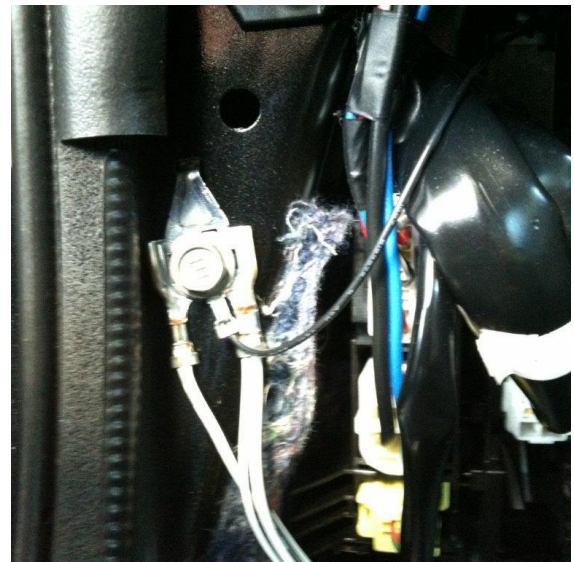

- Reinstall all panels and connectors inside car, including fog light switch connector

ENGINE COMPARTMENT

17. Remove 2x12 mm bolts holding the radiator supports from core support (picture 16)



Picture 16

18. Run harness along top of radiator and secure with a wire tie at each end (picture 15)



Picture 15

19. Reinstall radiator supports and torque to 14 ft-lb.
20. Run harness down right and left side of vehicle
21. On the driver side, remove the high beam bulb by turning it counter-clock. Caution: Do not touch glass part of bulb (pic. 16 and 16A)

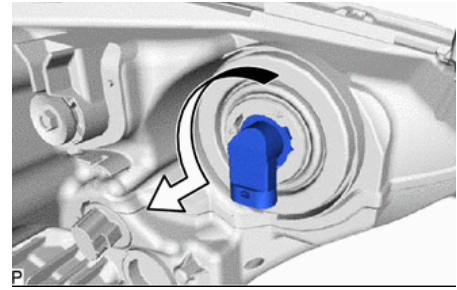

Picture 16



Picture 16A

22. Unplug the high beam socket from bulb, then connect the 9005 jumper harness from the fog light kit to the high beam wire harness and the high beam bulb (picture 17).



Picture 17

23. Reinstall bulb into headlamp
24. Plug white wire from jumper harness into white wire of fog light harness (picture 18)



Picture 18

25. Secure excess wires with wire ties behind headlamp (picture 19).



Picture 19

26. From under the car, remove driver side lower splash shield: There are 2 screws and one push-pin. Using a pry tool to remove push pin (pictures 20 and 20A)



Picture 20



Picture 20A

27. Remove fog light cover plates on both sides of vehicle (picture 21)



Picture 21

28. Insert one side of the LED fog lamp into the plastic sleeve and secure other side with factory screws (picture 22). Follow this step for both left and right fog lights.

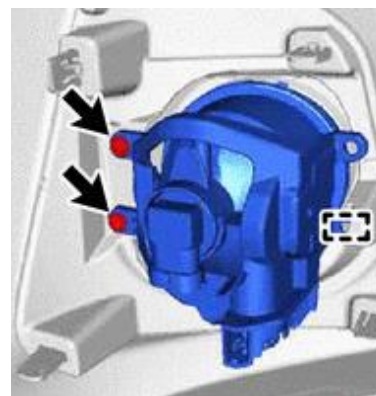

Picture 22

29. Note: For Halogen installations, proceed to step 30. For LED installations; The LED fog light wires may not be pushed into their connectors. If not, push the negative wire (black or black-white) into Pin 2 of the connector. Then, push the positive wire (red or red-white) into Pin 1 of the connector. See Picture 23 below.



LED Lights will NOT work if the polarity is reversed. Be sure the red positive wire of the harness matches the red positive wire of the light housing, and the black negative wire of the harness matches the black negative wire of the light housing.

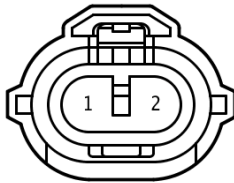

Picture 23

30. Plug Fog light connectors into fog lamps
31. Reattach the lower splash shields.
32. Replace Battery and reconnect negative battery cable. Torque to 61 in/lbs.

Check

Accessory Functions Checks

- Fog Lights function.....
- All Panels snapped into place.....
- Battery Terminal.....

Vehicle Function checks

- Check all vehicle functions

Look For:

- Inoperable fog light function
- Loose panels and switches
- Re-torque battery terminals to 61 in-lb