

Part Number: TCA-715



**Recommended Tools**

**Kit Contents**

Item #	Quantity Reqd.	Description
1	2	DRL housings w/integrated turn signal
2	1	Harness bag
3	1	User's card
4	1	Switch

**Hardware Bag Contents**

Item #	Quantity Reqd.	Description
1	1	Hood Wire Harness
2	1	Cabin Wire Harness
3	25	8" Wire ties
4	4	Black T-Taps
5	1	Relay
6		DRL white Connectors
7	1	10 mm nut

**General Applicability**

SE and LE MODELS
------------------

**Conflicts**

- XSE and XLE
---------------

<b>Safety Tools</b>	
Safety Glasses	
Protective tape	
Electrical Tape	
<b>Installation Tools</b>	
10mm Wrench	
Phillips Screw Driver	
Pliers	
Fish Tool	
Panel Tool Removal	
Side Cutters	
Torque Wrench	
<b>Special Chemicals</b>	
3M Silicon Sealant	

Mandatory

Legend

	<b>STOP:</b> Damage to the vehicle may occur. Do not proceed until process has been complied with.
	<b>OPERATOR SAFETY:</b> Use caution to avoid risk of injury
	<b>CRITICAL PROCESS:</b> Proceed with caution to ensure a quality installation. These points will be audited on a completed vehicle installation
	<b>TOOLS &amp; EQUIPMENT:</b> This calls out the specific tools and equipment required for this process
	<b>REVISION MARK:</b> This mark highlights a change in installation with respect to previous issue.

Care must be taken when installing this accessory to ensure damage does not occur to the vehicle. The installation of this accessory should follow approved guidelines to ensure quality installation.

## Preparation



Remove negative battery terminal

## Installation

1. From front of vehicle, run the DRL's wire harness on the driver side from the battery towards the firewall of the car. Use wire ties as needed (pictures 1).



Picture 1

2. Locate the large vehicle harness grommet on the left side. If accessible, cut the auxiliary wiring access nipple off the grommet or cut ¼" slit in grommet and push

the red, blue, black-white and white wires through firewall. Note: Extra caution should be taken not to damage the pin connectors. Seal with 3M Silicone sealant (picture 2).



Picture 2

## Vehicle Disassembly

3. Remove driver side door scuff plate.
  - a. Disengage with panel tool and remove (picture 3).

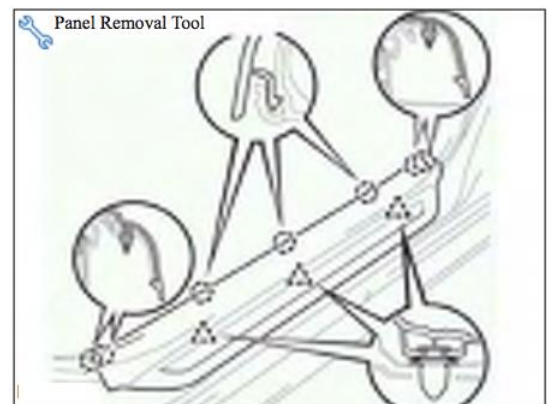

Picture 3

4. Remove the driver side cowl side trim (picture 5).
  - a. Unscrew the cowl side trim clip.

- b. Disengage two (2) clips and remove the cowl side trim (picture 4).

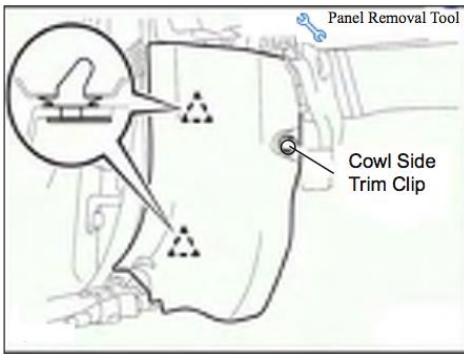

Picture 4

- 5. Remove side panel from dash, pry outward at front edge then pull straight back (pic.5).



Picture 5

- 6. Disconnect the hood lock control lever sub-assy: Disengage the claw and 2 guides to disconnect the hood lock control lever sub-assembly (picture 6).

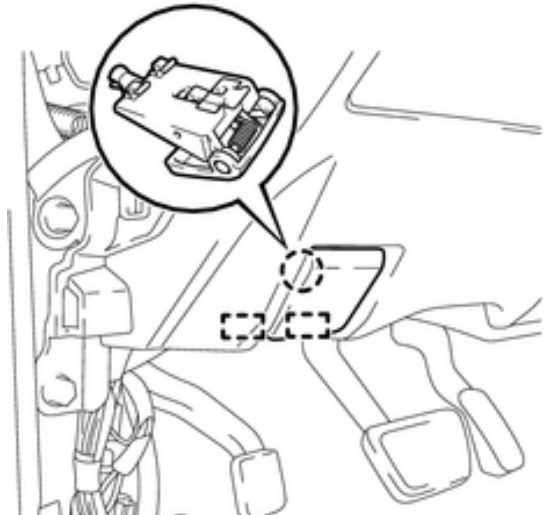

Picture 6

- 7. Remove the lower instrument panel by removing one screw and one bolt (picture 7).

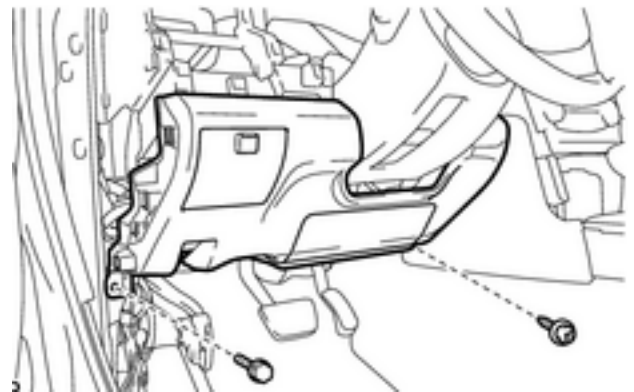

Picture 7

- 8. Remove dash plug then mount switch into switch knockout on left side of dash (pic. 8).



Picture 8

- 9. From inside the cabin, locate the wires that were pushed through in step 2. It will be the grommet above the gas pedal.
- 10. Push the pins into the white connector, making sure they aligned properly with the colors of the cabin wire harness section (picture 9)



Picture 9: Hood harness. Connect to match colors in pic 9A



9A



9B

- 11. Route the wire harness to reach the left area of the steering wheel.

- 12. Connect the cabin section of the wire harness to the wire harness pushed through the firewall.
- 13. Install a black t-tap to connector 3D pin 5, green wire. Then connect the **white** wire from DRL harness to the t-tap. Connector 3D is located in the main junction block (pictures 10~10D).

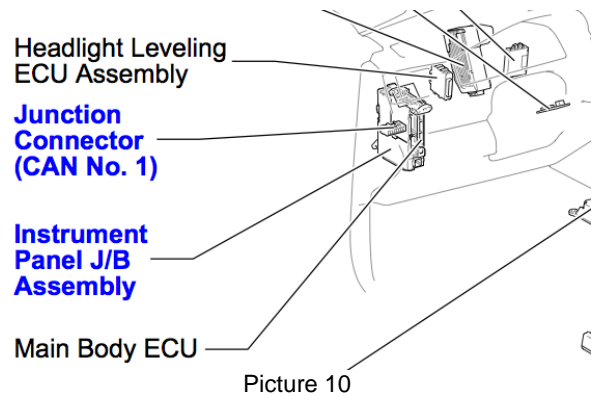

Picture 10

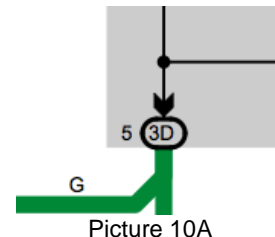

Picture 10A

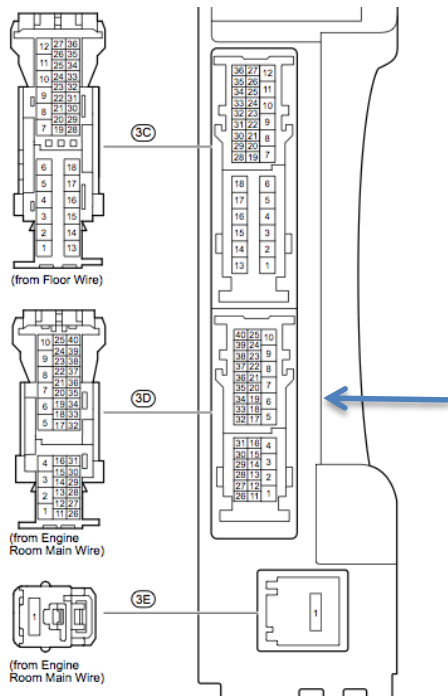

Picture 10B

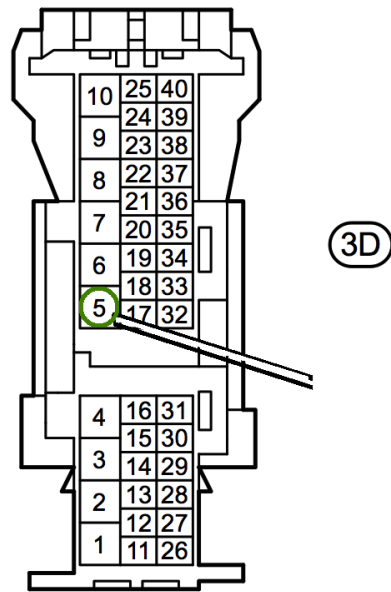

(from Engine Room Main Wire)

Picture 10C

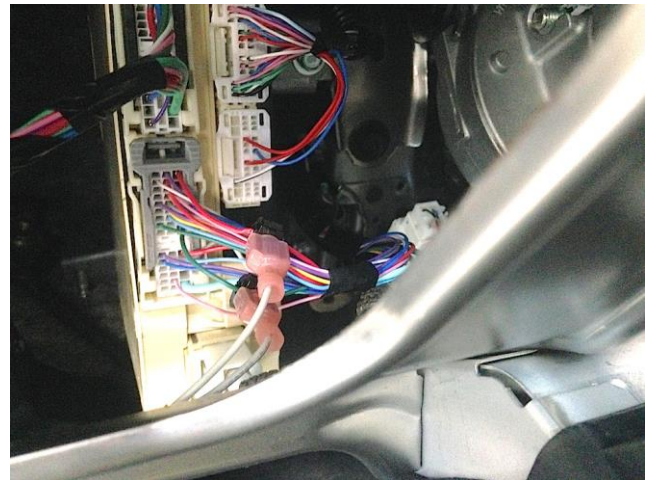

Picture 10D: DRL white wire to connector 3D, pin 5, green wire (15A Turn&Haz Fuse)

- Install a black t-tap to connector 3D pin 10, red wire. Then connect the **white-black** wire from DRL harness to the t-tap (pictures 10D, 11~11A).

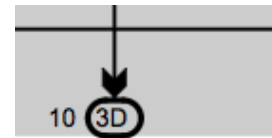

Picture 11

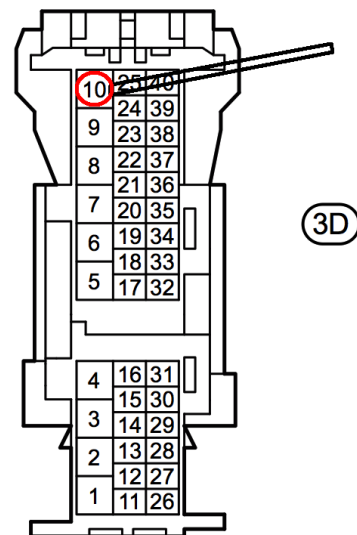

(from Engine Room Main Wire)

Picture 11A: DRL White-Black wire to connector 3D, pin 10, red wire (15A Turn&Haz Fuse)

15. Install a black t-tap to connector K12 pin 19, blue wire. Then connect the red wire from DRL harness to the t-tap. Connector K12 is located at the kick panel. (pictures 12~12C).

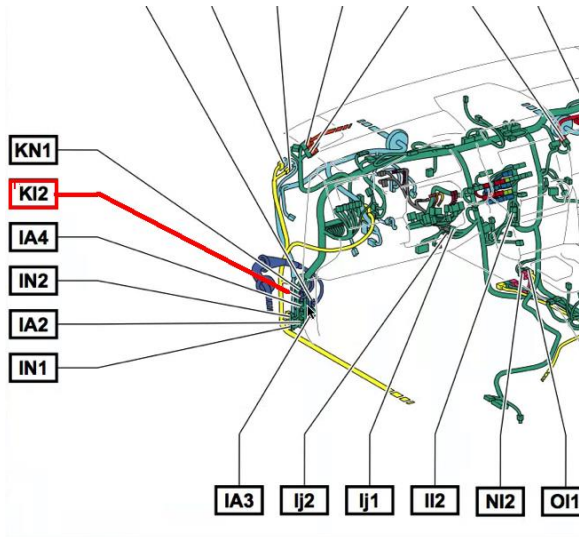

Picture 12

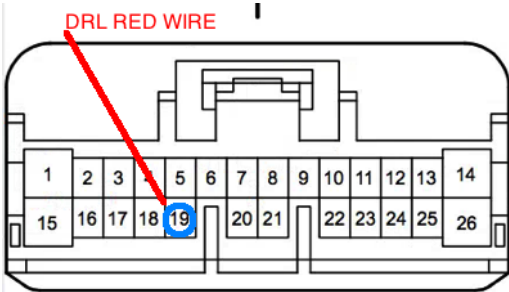

Picture 12A: DRL red wire to connector K12, pin 19 (blue wire)  
(7.5A ECU-ACC Fuse)

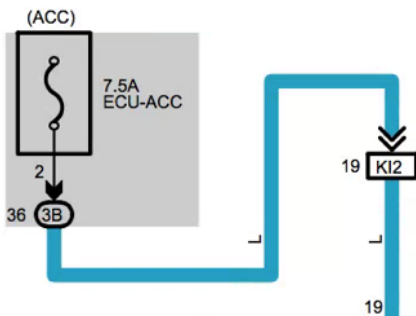

Picture 12B



Picture 12C

16. Install a black t-tap to connector K12 pin 12, green wire. Then connect the blue wire from DRL harness to the t-tap (pictures 12C, 13~13A).

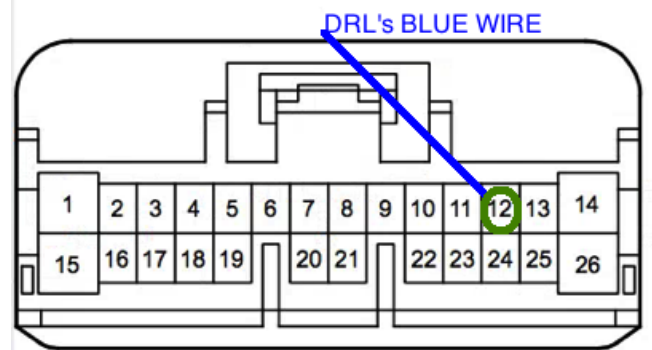

Picture 13: DRL blue wire to connector K12, pin 12 (green wire)  
(10A Panel Tail Relay Fuse)

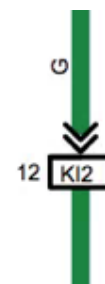

Picture 13A

17. Secure any excess wire and relay with wire ties (picture 14).



Picture 14

18. Using supplied 10mm nut, secure relay to 10mm bolt next to the main JB assembly (picture 15).

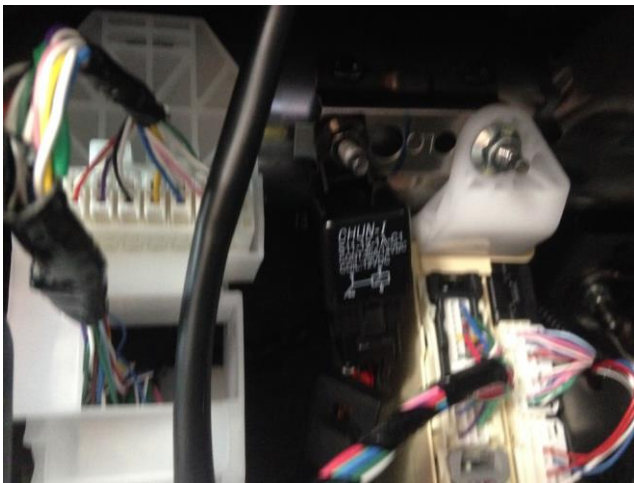

Picture 15



19. Reinstall airbag, dash panels and connectors. Note: If knee airbag was removed, then reinstall it following specifications on picture 15.

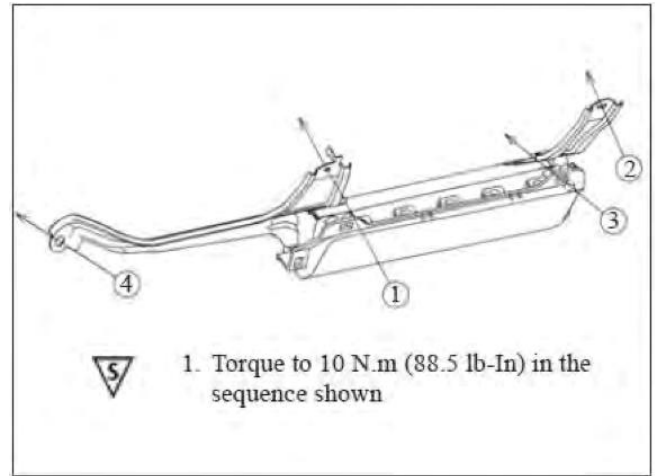

Picture 15

### ENGINE COMPARTMENT

20. At the driver side, route the DRL's wire under car.
21. Remove lower splash shield by removing 5 screws and 3 push pins. (picture 16).

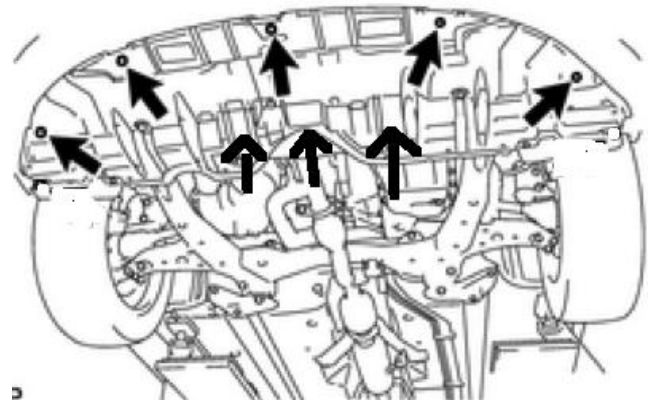

Picture 16

22. From under the car, on the driver side, connect the ring terminal with the black wire to the ground point next to the battery: ground point location A2 (pics. 17~17A).

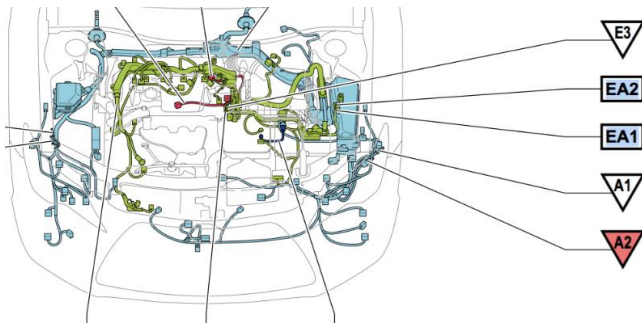

Picture 17

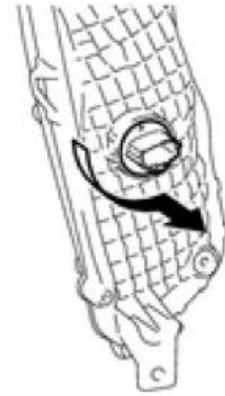

Picture 19

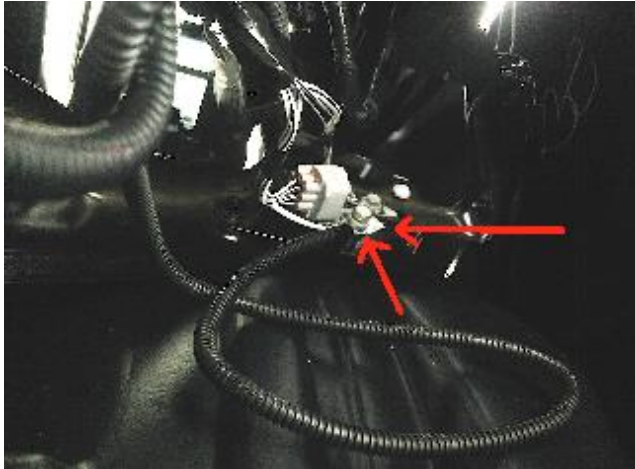

Picture 17A

23. At the driver side, remove the turn signal assembly: remove the 2 screws (pic. 18).  
*Note: Do not discard the factory screws as these will be used later.*

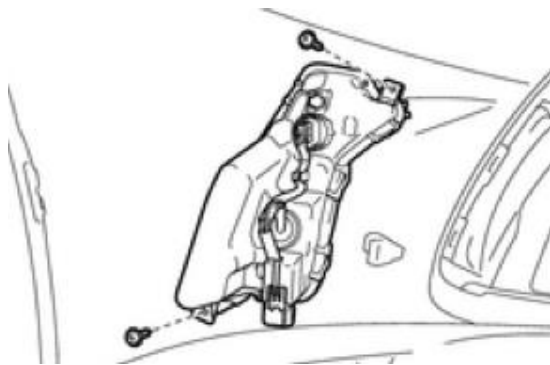

Picture 18

24. Remove the front turn signal and parking light bulb from the housing: Turn the front turn signal light socket counter-clock wise and then pull socket (picture 19).

25. Using the factory screws removed in step 21, install the LH LED DRL housing into the bumper.
26. Reinstall the turn signal bulb into the DRL housings.
27. From under the car, run the DRL wire harness to the passenger side. Secure with wire ties as shown in pictures 20~20C.



Picture 20: behind LH DRL, to metal sheet.



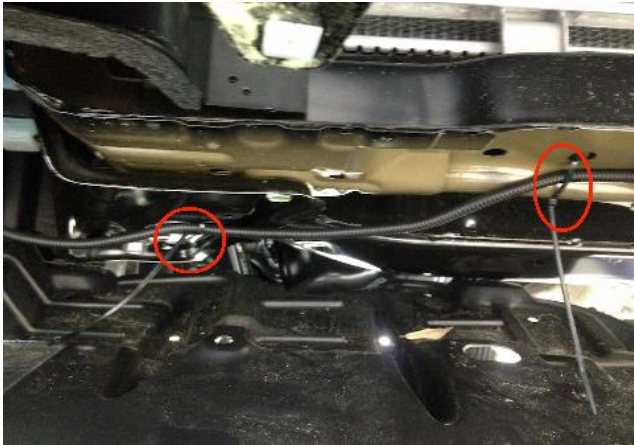

Picture 20A: Under radiator, to metal sheet.



Picture 20B: Under radiator to metal sheet towards passenger side.

28. Repeat steps 23~26 at the passenger side.
29. Secure any excess wire (picture 21).



Picture 21: At passenger side, by washer fluid reservoir.

30. Reattach the lower splash shields.



31. Reinstall negative battery terminal.  
Torque battery terminal to 48 lb-in.



**Checklist** – these points MUST be checked to ensure quality installation

**Check System for Operation**

- 1. While switch is in “ON” position (green indicator light on switch will illuminate), DRL will work at full power when ignition switch is ON.
- 2. DRL will dim out to DOT specifications when vehicle lights are “ON”
- 3. If DRL switch position is “OFF”, DRL will not work at any time

**Check**

Accessory Functions Checks

---

- DRL function.....
- All Panels snapped into place.....
- Battery Terminal.....

Vehicle Function checks

---

- Check functions all switch functions

**Look For:**

---

- ....
- Loose panels and switches
- Re-torque battery terminals to 48 in-lb