



LED Fog Light

Year & Model	2017 – Prius
Part Number	TPR-817

Conflicts

Note:	1226, 1228
-------	------------

General Applicability

Fits Models	
1221	1225
1223	1227
1224	

Additional Items Required For Installation

Items	Description
1	N/A
2	

Sequence of Application

Item	Description
1	N/A
2	

SPECIAL NOTE: Installation Sequences

After Auer Automotive & Safety mandated preparatory steps have been taken, the installation sequence is the suggested method for completing the accessory installation. In some instances the suggested sequence is written for one associate to install & in others the sequence is given as part of a team accessory installation. Unless otherwise stated in the document, the associates may perform the installation steps in any order to make the installation as efficient as possible while maintaining consistent quality

Recommended Tools

Safety Items	
Safety Glasses	
Special Tools	
N/A	
Installation Tools	
10 mm Wrench	Pliers
12 mm Wrench	Side Cutters
Torque Wrench	Fish wire tool
#2 Phillips screw driver	1/8” drill bit
Short Nylon Tool	15/16”step bit
	#2 stubby Phillips screw driver
Special Chemicals	
VPC Approved sealant	

Legend

	STOP: Damage to the vehicle may occur. Do not proceed until process has been complied with.
	OPERATOR SAFETY: Use caution to avoid risk of injury.
	CAUTION: A process that must be carefully observed in order to reduce the risk of damage to the accessory/vehicle and to ensure a quality installation.
	TOOLS & EQUIPMENT: Used in Figures calls out the specific tools and equipment recommended for this process.
	REVISION MARK: This mark highlights a change in installation with respect to previous issue.
	SAFETY TORQUE: This mark indicates that torque is related to safety.

Table of Contents

Preparation	3
Kit/Hardware Bag Contents	3
Wire Harness Bag Contents	3
Parts for Installation	4
Procedures:	5
Vehicle Disassembly/Installation Process	5
Vehicle Reassembly	20
Fog Light Aiming.....	22
Functions and Quality Check.....	23
Diagnostics and Procedures:.....	24
Block Diagram.....	24
Switch drill template.....	27

Preparation

Kit/Hardware Bag Contents

Item#	Qty	Description
1	2	LED Light Housings w/bezels
2	1	Wire Harness Bag
3	1	In dash Switch w/pig tail
4	1	Dash switch drill template
5	1	Fog Light operation guide

Wire Harness Bag Contents

Item#	Qty	Description
1	1	Under-Hood Wire Harness
2	1	In-dash wire harness
3	3	Red t-tap
4	1	Relay box
5	25	Wire Ties

Parts for Installation

Care must be taken when installing this accessory to ensure damage does not occur to the vehicle. The installation of this accessory should follow approved guidelines to ensure a quality installation. These guidelines can be found in the “Accessory Installation Practices” document.

This document covers such items as:

- Vehicle Protection (use of covers and blankets, cleaning chemicals, etc.).
- Safety (eye protection, re-checking torque procedure, etc.).
- Vehicle Disassembly/ Reassembly (panel removal, part storage, etc.).
- Electrical Component Disassembly/Reassembly (battery disconnection, connector removal, etc.).

Item	Quantity	Description
1	1	LED Fog Light Housing - LH
2	1	LED Fog Light Housing - RH
3	1	Prius Fog Light Bezel - LH
4	1	Prius Fog Light Bezel - RH
5	1	Switch w/pig tail
6	1	Wire Harness
7	1	Relay



1.



2.



3.



4.



5.



6.



7.

Procedures:

Vehicle Disassembly/Installation Process

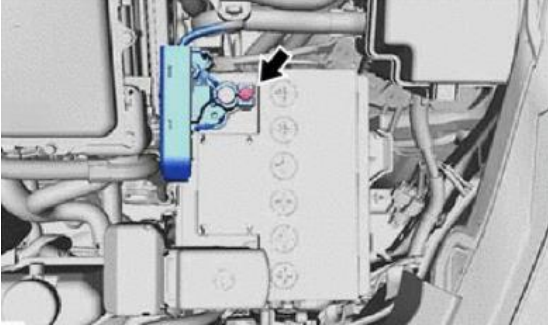

Picture 1

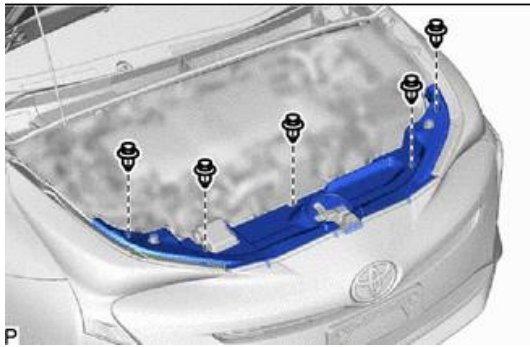

Picture 2



Picture 3

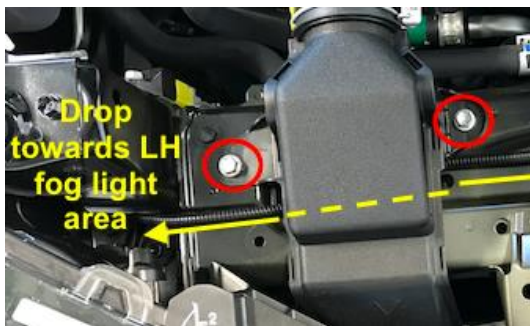

Picture 4

1. Remove the 10mm negative battery terminal (picture 1).
2. Remove the radiator support opening cover: remove 5 push pins (picture 2).
3. Lay the under-hood wire harness along front of the engine compartment: marked in green (picture 3).
4. Remove 2x10mm bolts (red circles on picture) to raise breather, and route the wire harness underneath it: Then reinstall the 2x10mm bolts back into place (red circles in picture 4). Torque bolts to 35 in-lb (4.0 Nm).
5. At the passenger side of the vehicle, route the under-hood wire harness to reach the RH fog lamp compartment (picture 4). Route wire along hood radiator bracing across front of engine compartment.

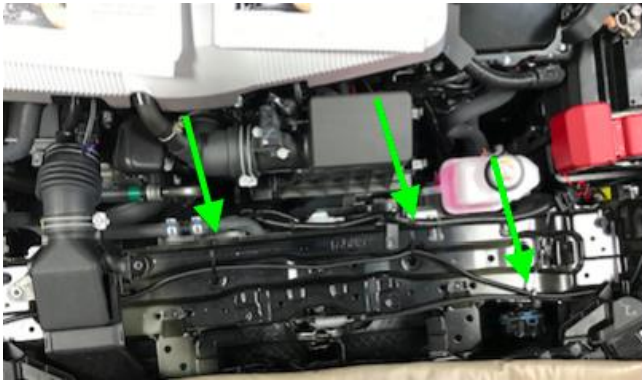

Picture 5

- Secure loosely with wire ties. Wire ties will be tightened after wire harness adjustment (picture 5).

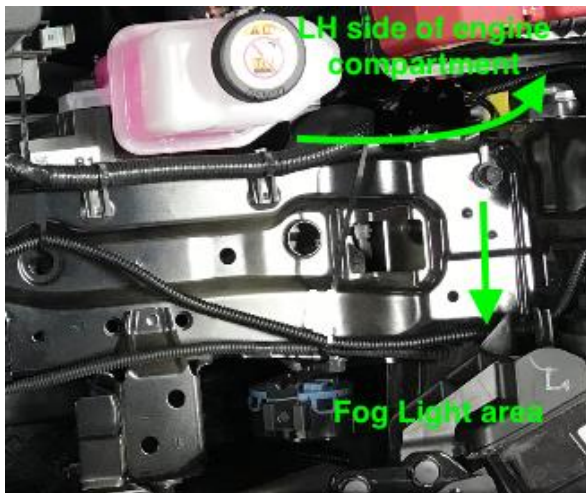

Picture 6

- At the driver side of the vehicle, route the under-hood wire harness (fog light terminal) to reach the LH fog lamp compartment (marked with a green arrow in picture 6).

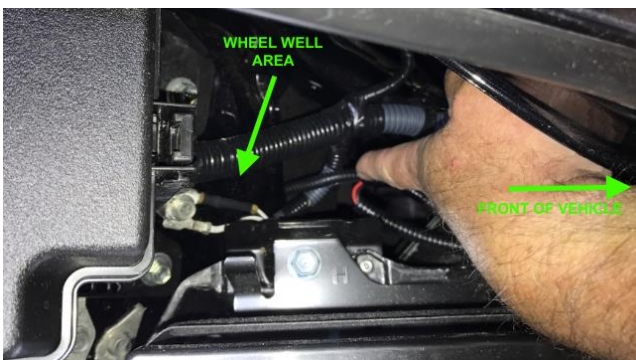

Picture 7

- Continue routing the under-hood wire harness (bullet connectors end) through LH side of the engine compartment into the wheel well area (picture 7).

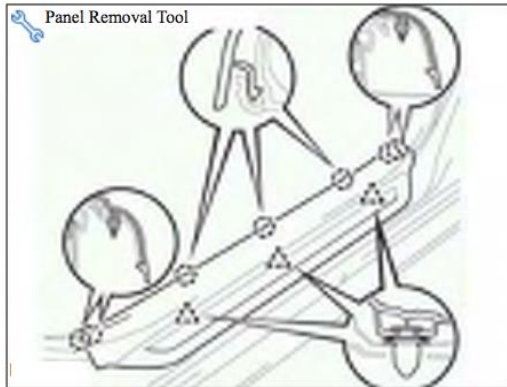

Picture 8

9. Remove driver's side door scuff plate: disengage with panel removal tool and remove (picture 8).

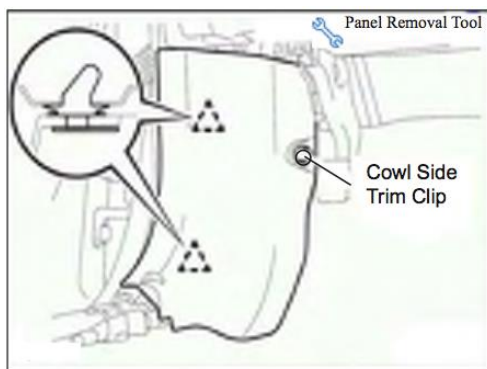

Picture 9

10. Remove the driver side cowl side trim: Unscrew the cowl side trim clip. Disengage two (2) clips and remove the cowl side trim (picture 9).



Picture 10

11. Pull the carpet up on the driver's side, to access the Styrofoam support. Then remove the Styrofoam support by rotating the 2 white retainers (picture 10).

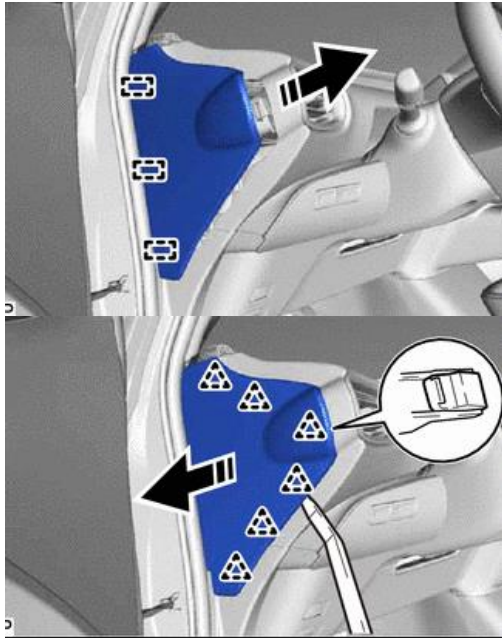

Picture 11

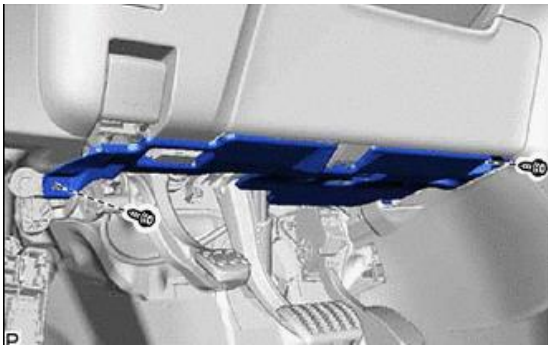

Picture 12

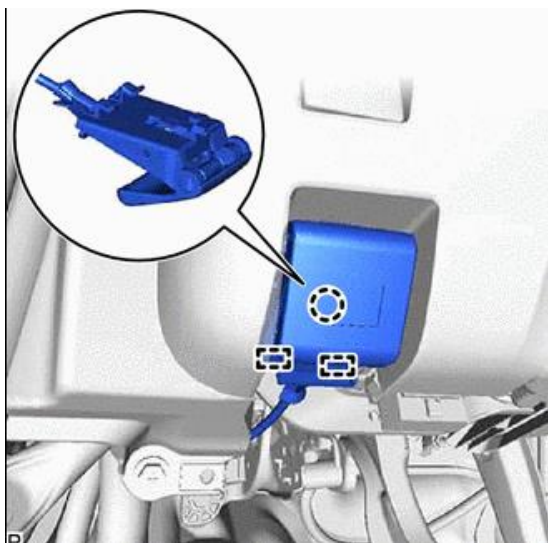

Picture 13

12. Use a panel removal tool to remove the instrument LH panel finish panel end: Disengage 6 clips (picture11).

13. Remove instrument panel under cover sub-assy: Remove 2 Philip screws, then pull down (picture 12).

14. Disconnect hood lock control lever: disengage the claw and 2 guides to disconnect the hood lock (picture 13).

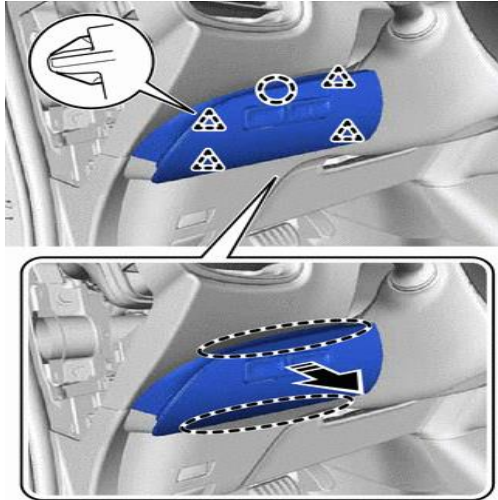

Picture 14

15. Remove lower switch panel by releasing 5 clips. Unplug wire harness(s) from back of switch panel (picture 14).

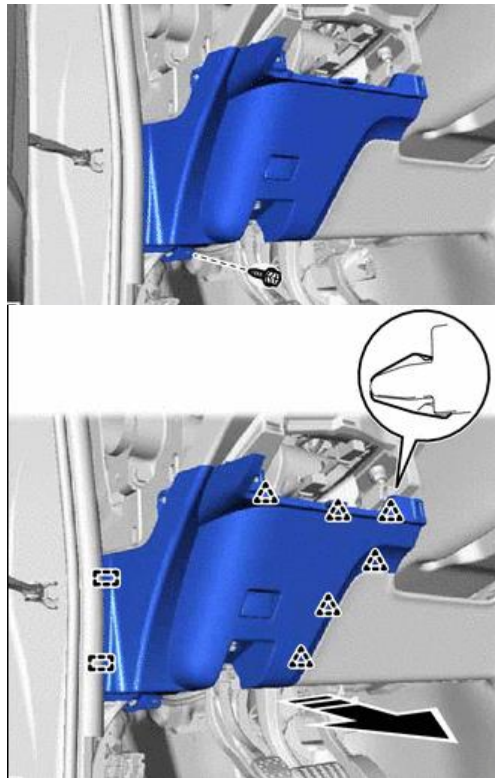

Picture 15

16. Remove the lower instrument finish panel assy: remove a 10mm bolt, then pull panel to disengage 6 clips (picture 15).

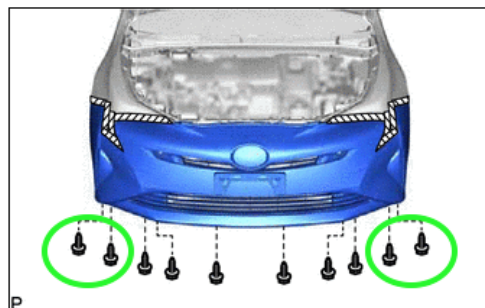

Picture 16

EXTERIOR OF VEHICLE

17. Remove 2 x10mm bolts on each side of bottom cover panels (picture 16).

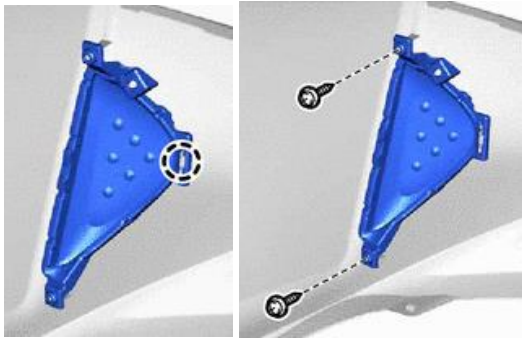

Picture 17

18. From behind the bumper, remove the fog light cover plates by removing 2 Philips screws (retain screws) and releasing 1 tab that secure the cover plate to the bumper. Remove the cover plate by pushing it towards the rear of the vehicle. Discard cover plates (picture 17).

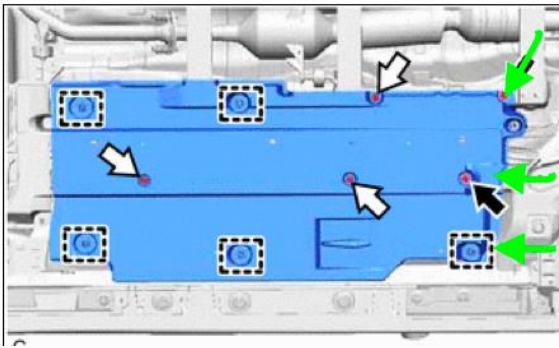

Picture 18

19. From under the car, remove 2x10mm bolts and 1 threaded panel retainer (marked with green arrows on picture 18) from the splash panel below the driver seat, to gain access to the drain plug under the driver seat: It is not necessary to remove the panel (pictures 18-18A).

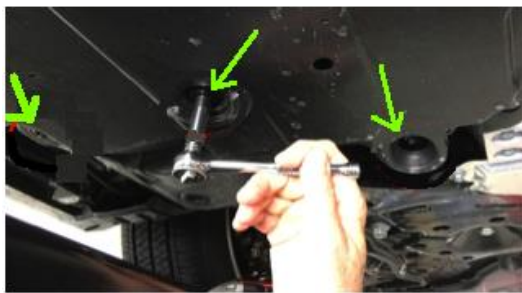

Picture 18A

20. Remove two push pins and 1x10mm bolt from the fender liner: the fog light wire harness will be inside the fender liner. ABOVE the wheel well, and then down towards under the car (pictures 19-19B).



Picture 19: Yellow lines show the wire harness path.

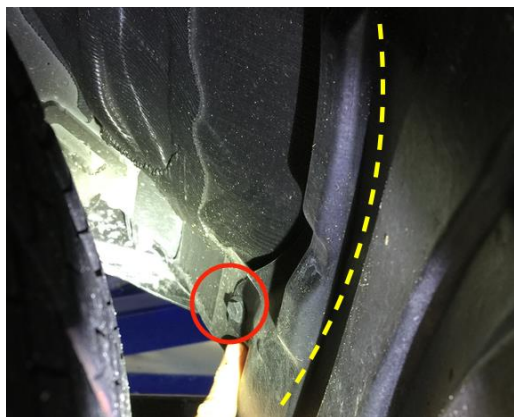

Picture 19A



Picture 19B



Picture 20:

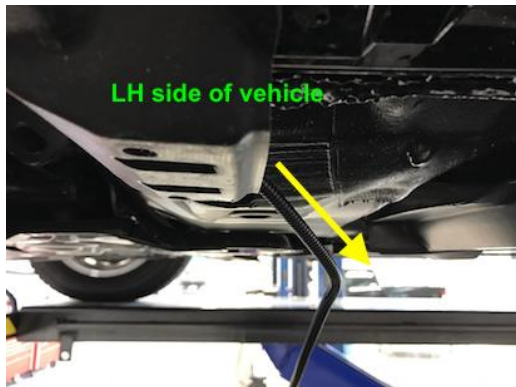

Picture 20A



Picture 21



Picture 22

21. Run the wire harness behind the fender liner, ABOVE the wheel well, then retrieve wire harness from the lower LH splash panel under the driver seat (pictures 20-20A).

22. At the driver side, pull down the splash panel below the driver side. Then remove the 1” rubber grommet under the driver seat: marked with a yellow arrow (picture 21).

23. Run the wire harness inside the cabin, through the bottom 1” hole. Then install the rubber grommet of the wire harness (picture 22). The rubber grommet is fixed to the wire harness.



Picture 23

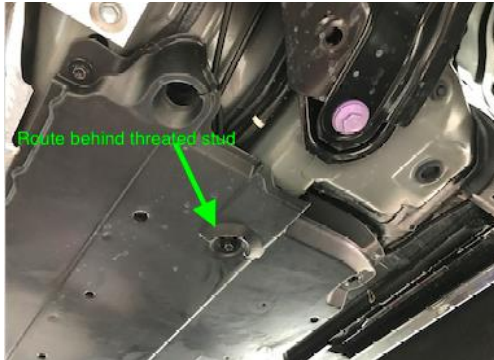

Picture 23A

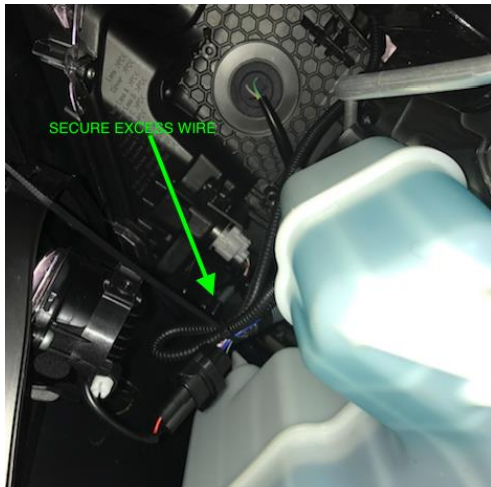

Picture 24



Picture 25

24. Return the lower splash panel to its original position, and secure the wire harness with a wire tie, to the hole of the splash panel next to the grommet (picture 23). It is recommended to secure the panel at this point, using the factory fasteners.

Ensure that wire harness is not touching the brake lines and route behind lower panel threaded stud (picture 23A).

25. From behind, install the driver side fog lamp housing and bezel into bumper. Use factory fasteners, removed on step 17, to secure the bezel assembly to the bumper.

26. Connect the fog light to wire harness, and secure harness with wire ties to factory harness behind fog lights (picture 24). Secure excess main harness behind driver side fog light.

27. Repeat process (steps 25 and 26) on passenger side.

28. Reinstall the 2x push pins and 1x10mm bolt removed from the front left fender liner (picture 25).

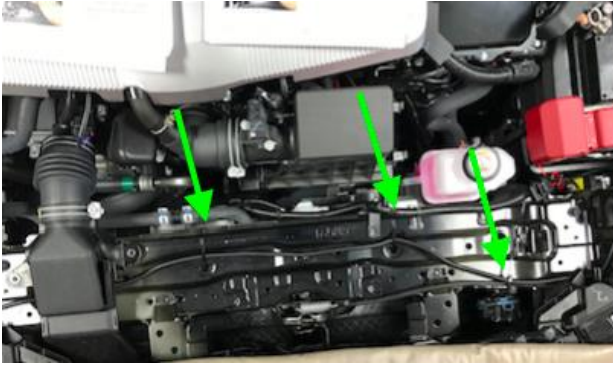

Picture 26

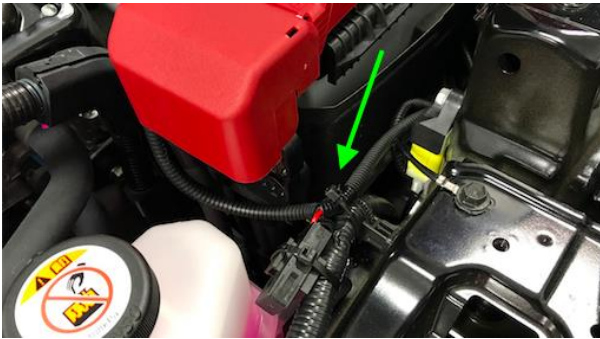

Picture 27

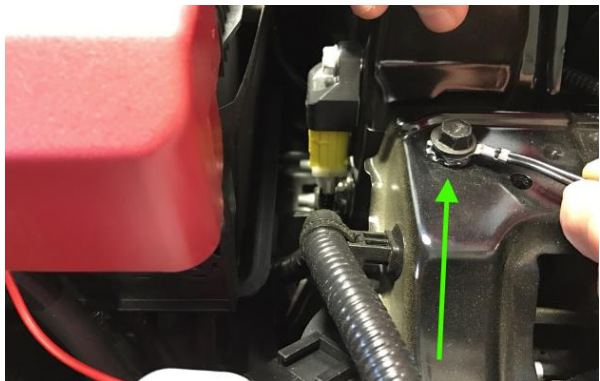

Picture 28



Picture 28A

29. Tighten previously installed wire ties (step 6) to the top of the radiator bracket, wire ties shown with green arrows on picture 26.



30. Secure the positive ring terminal connector (red wire) of the under-hood wire harness to the 10mm positive battery terminal. Route it through the terminal cover (picture 27). Torque nut to 48 in-lb.

31. Secure the negative ring terminal connector (black wire) of the under-hood wire harness to radiator support 10mm bolt next to battery: Use the supplied star washer (picture 28).

32. Using a wire tie, secure the under-hood fuse next to the battery to factory wire harness (picture 28A).

33. Use wire ties to secure the wire harness as needed.

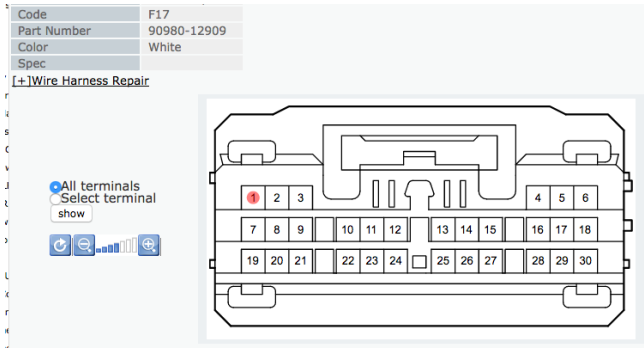

Picture 29: Pin 1, beige wire

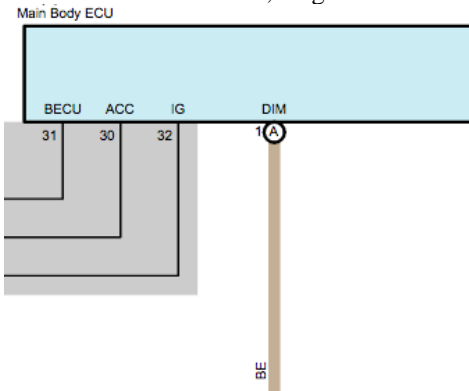

Picture 29A: Headlight DIM circuit.
Connector F17, pin 1, beige wire.

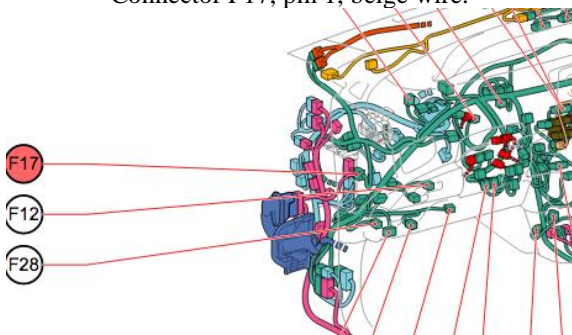

Picture 29B: Connector F17 is at junction block by kick panel

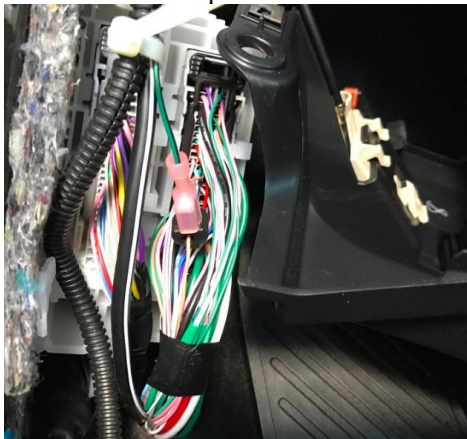

Picture 29C: Green-black wire connected to beige wire.

INSIDE OF VEHICLE

- At connector F17, pin 1, beige wire, Install a red t-tap. Then connect the **green/black** wire from the in-dash switch harness to the red t-tap. Connector F17 is located at the junction block by the kick panel (pictures 29-29C).

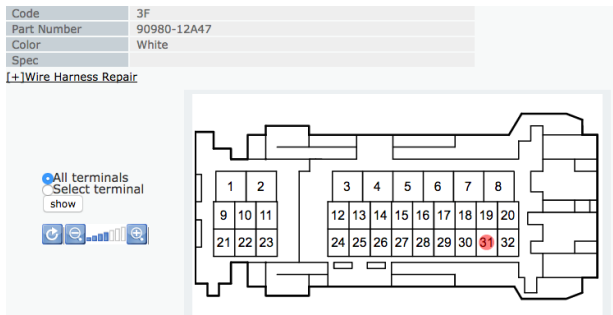

Picture 30: Pin 31, Beige wire.

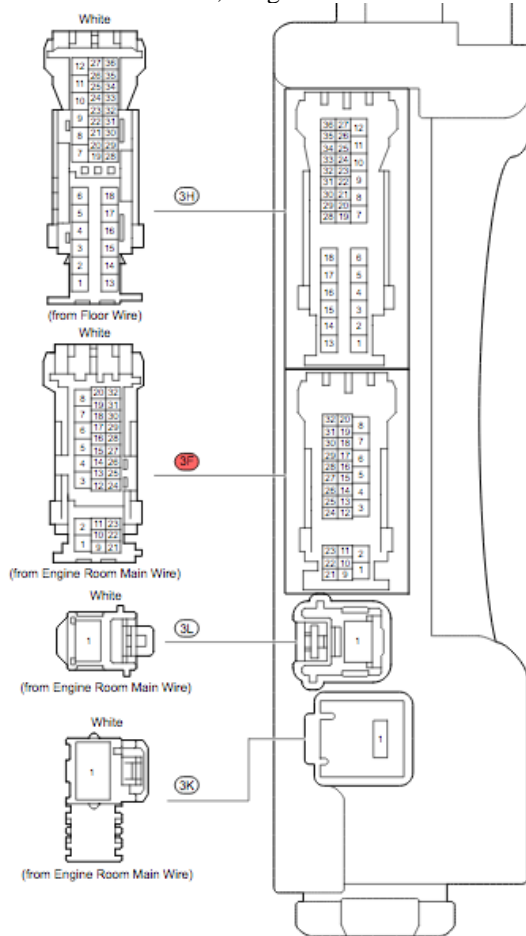

Picture 30A: Location of connector 3F

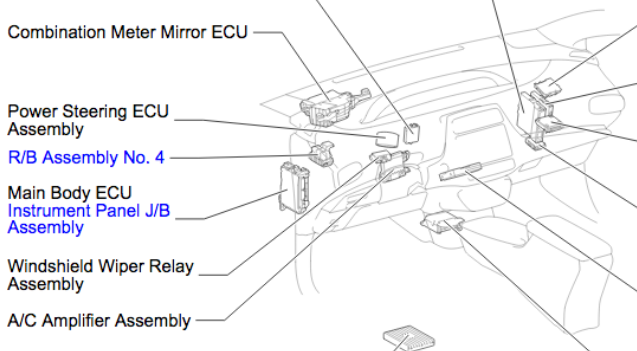

Picture 30B: Connector 3F is at the JB, by kick panel.

35. At connector 3F, pin 31, beige wire, Install a red t-tap. Then connect the **orange/black** wire from the in-dash switch harness to the red t-tap. Connector 3F is located at the junction block by the kick panel (pictures 30~30D).



Picture 30C

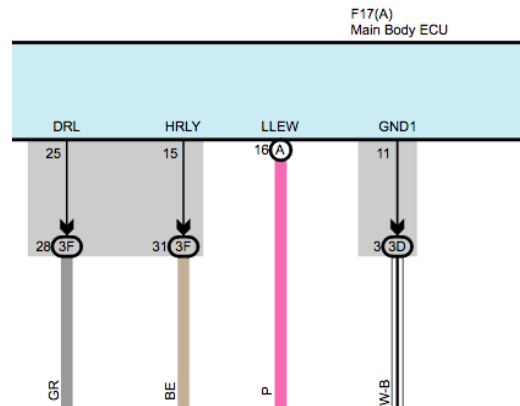

Picture 30D: Headlight relay circuit wire Connector 3F, pin 31, beige wire.

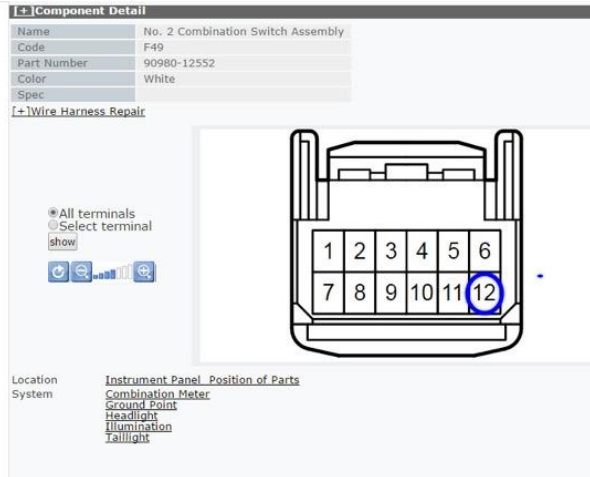

Picture 31

36. At connector F49, pin 12, blue wire, Install a red t-tap. Then connect the **red/white** wire from the in-dash switch harness to the red t-tap. Connector F49 is located at the lower left switch panel. (pictures 31-31C).

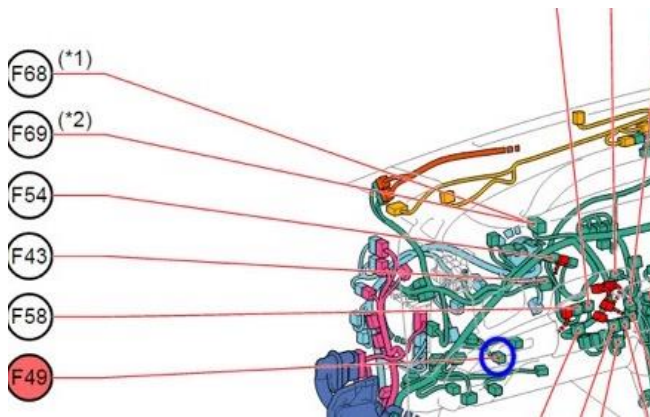

Picture 31A: Location of F12

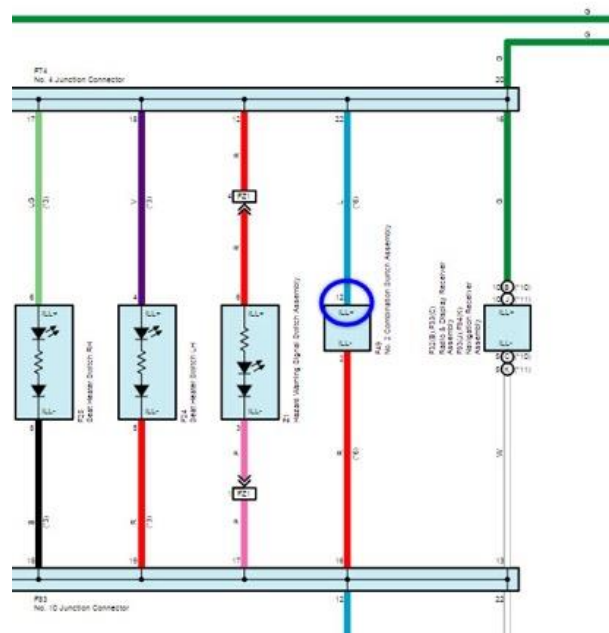

Picture 31C: Connector F12, pin8 (combination switch).

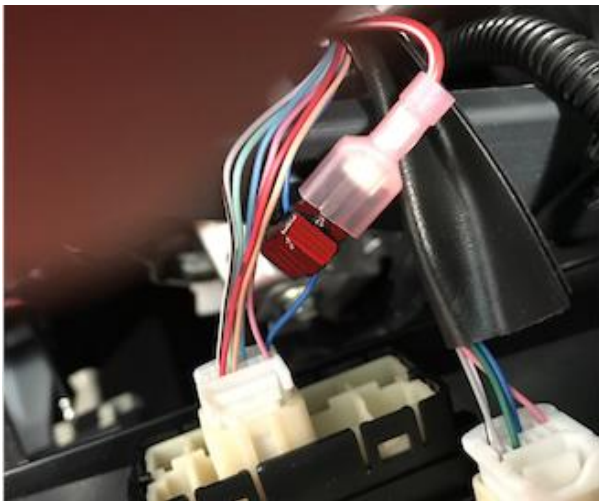

Picture 31B: Red-white wire connected to blue wire.



Picture 32

37. Secure the ring terminal (black wire) of the in-dash switch harness to the ground point next to the kick panel (picture 32).



Picture 33

38. Locate the wire harness that was pushed in from under the car. It will be under the driver's side carpet (picture 33).

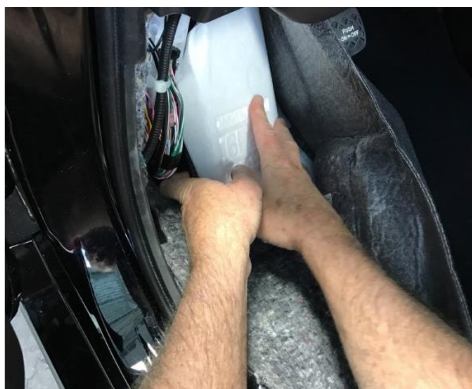

Picture 34

39. Route wire harness under the carpet, then under the white Styrofoam support location, then towards the lower left dash panel (pictures 33-34).

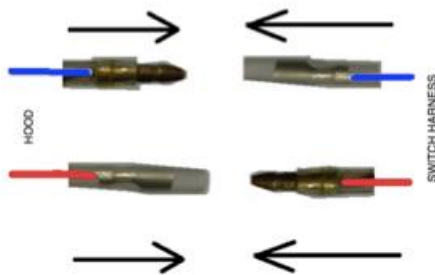

Picture 35

40. Connect the bullet connectors of the in-dash switch harness to the under-hood harness (picture 35).



Picture 36



Picture 37



Picture 38



Picture 39

41. Connect the relay box to the white connector of the in-dash switch harness and secure with wire ties to factory harness (picture 36).
42. Secure fuse and excess wire with wire ties to factory harness as shown on picture 36. NOTE: make sure to leave enough slack on the switch harness to plug in switch pig tail.
43. Put the lower instrument panel on a protected bench. Place the supplied template behind the panel. Drill a 1/8" pilot hole at the center hole mark. Then, drill a 15/16" (or 24mm) hole with a 15/16" step bit from the front of the panel (picture 37).
44. Install the switch into the dash switch panel (picture 38).
45. Connect the fog light switch pig tail to the in-dash fog light harness. Reinstall the lower instrument finish panel assy: push panel then secure with removed fastener(s) (picture 39).

Vehicle Reassembly

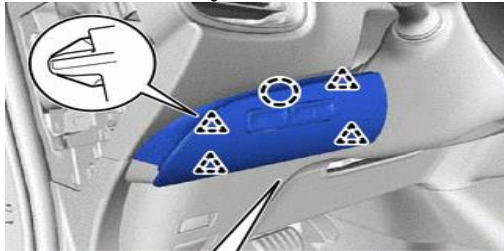

Picture 40

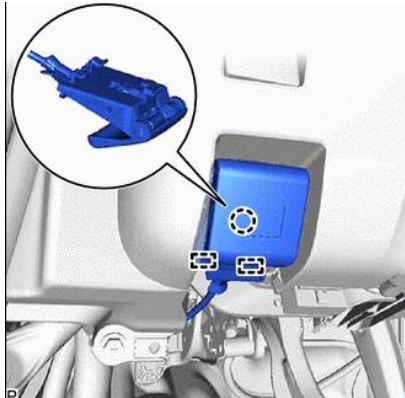

Picture 41

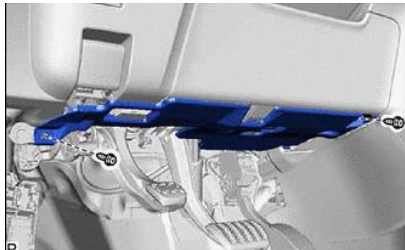

Picture 42

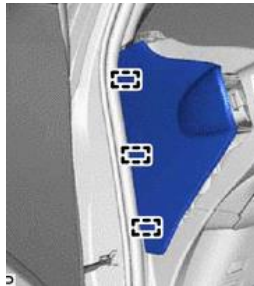

Picture 43



Picture 44

46. Reinstall factory switch connectors behind switch panel. Then apply pressure on the panel to snap into place (picture 40).

47. Reconnect hood lock control lever: engage the claw and 2 guides (picture 41).

48. Reinstall instrument panel under cover sub-assembly and secure with removed fasteners (picture 42).

49. Reinstall the LH finish panel end: apply pressure on the panel to snap into place (picture 43).

50. Reinstall the Styrofoam support from under the driver's side carpet. Secure with white fasteners (picture 44).

51. Reposition carpet to the driver's side floor board area.

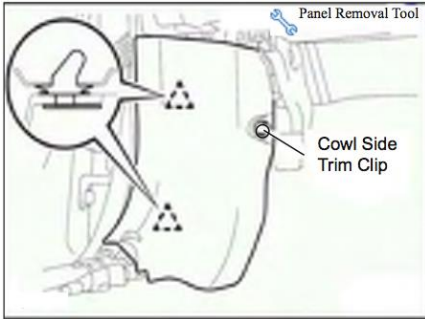

Picture 45

52. Reinstall the driver side cowl side trim (picture 45).

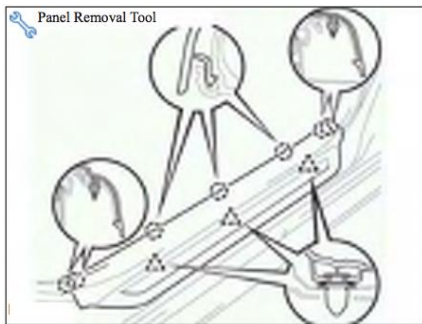

Picture 46

53. Reinstall the driver side door scuff plate (picture 46).

EXTERIOR OF VEHICLE

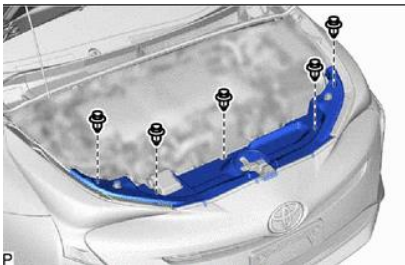

Picture 47

54. Reinstall the radiator support opening cover using removed fasteners (picture 47).



Picture 48

55. Reconnect battery terminals. Torque to 48 in-lb (picture 48).



Picture 49

56. Align fog lights following fog light guide on pg 28. Reinstall lower splash panels: secure two screws on each side (picture 49).

Fog Light Aiming

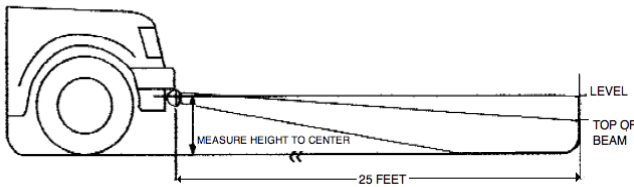

Picture 50



NOTE: Use only hand tools to adjust the fog light aiming screw. DO NOT use automatic tools, as they will damage the fog light

Traditional fog lights are usually mounted in the front bumper about 10-24 inches from the ground. There are two important issues to address when installing fog lights: the first is to minimize the amount of return glare into the driver's eyes, and the other is to minimize the glare into oncoming eyes. Both of these issues must be accomplished while putting as much light as possible on the road.

These fog weather light aiming instructions are suggestions taken from common practice and the S.A.E. standard J583. Some modifications to these instructions may be necessary to minimize glare.

Visual aim is made with the top of the beam 4 inches below the lamp center at 25 feet with the lamp facing straight forward (see picture 50).

Functions and Quality Check

1. Turn on headlamp low beams, then press fog light switch to “ON” position. Fog lights should be working. Fog lights will only work when the low beam headlamps are “ON”. Fog lights will NOT work when the high beam headlamps are “ON”.

Check	Look For
Accessory Function Checks	
<input type="checkbox"/> Fog Light Function	- Inoperable Fog Light Function
<input type="checkbox"/> All Panels snapped into place	- Loose panels and switches
<input type="checkbox"/> Battery Terminal	- Re-torque battery terminals to 48 in-lb
<input type="checkbox"/> Operation Guide	- Place Fog Light operation guide inside glove box
Vehicle Function Checks	
<input type="checkbox"/> Check all vehicle functions	

Diagnostics and Procedures:

Block Diagram

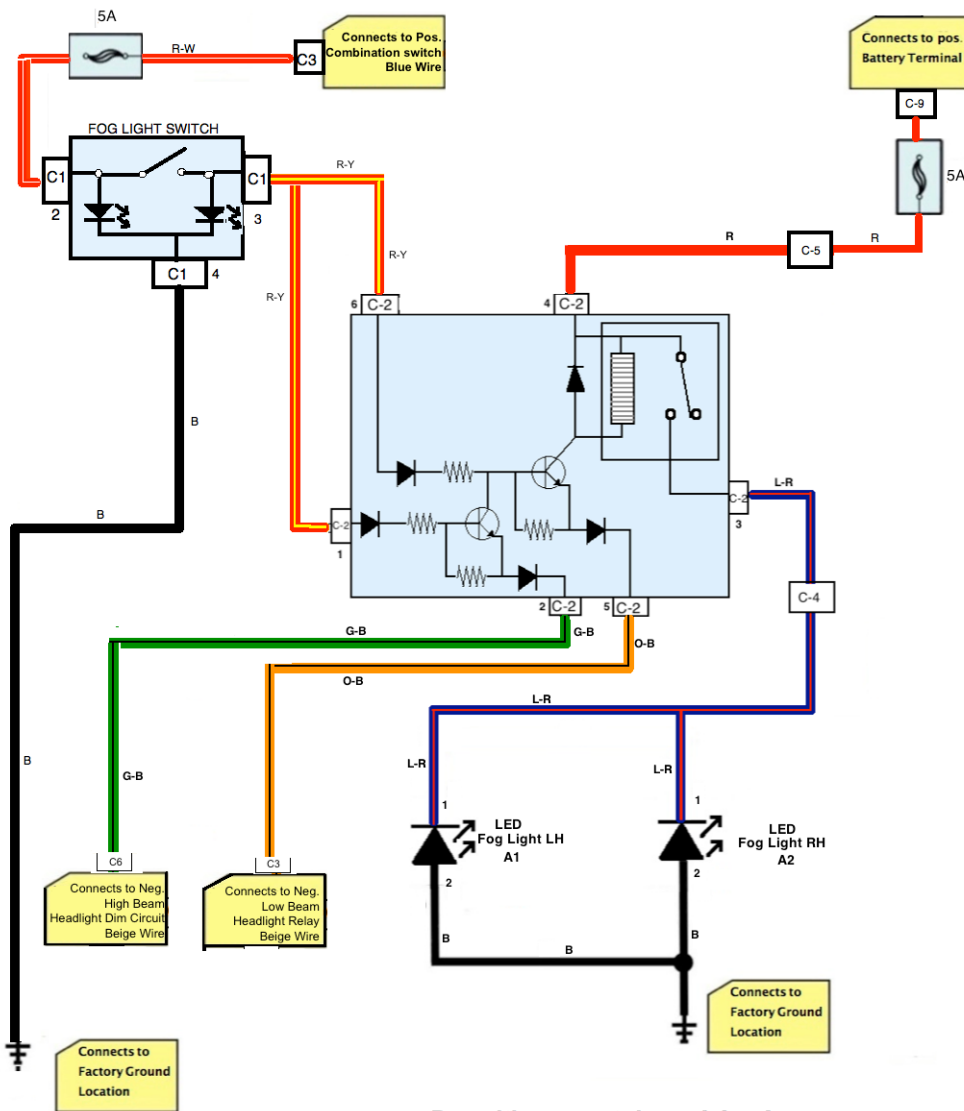
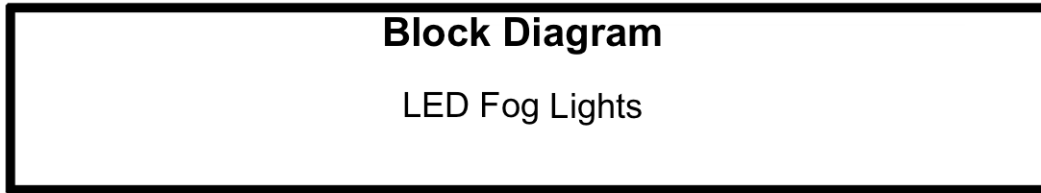

Pin out Test

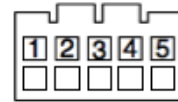

Connector C-1

**Unplug connector from switch prior to testing pin outs

Pin	Wire Color	Test Reference	Proper Operation
1	Black	Pin 1 to Ground	Aprox. +12 VDC when headlights are OFF or HIGH BEAMS ON 0 VDC when headlights are ON (LOW BEAM position)
2	Red	Pin 2 to Ground	Always +12 VDC
3	Gray-White	Pin 3 to Ground	Approximately +12 VDC when FOG LIGHT switch is OFF Approximately +12 VDC when headlights are OFF or HIGH BEAMS ON 0 VDC with FOG LIGHT switch ON and headlights are ON (LOW BEAM position)

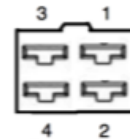

Connector C-2

**Leave Relay connected while testing the pinouts

Pin	Wire Color	Test Reference	Proper Operation
1	Blue Red	Pin 1 to Ground	Approximately 0 VDC when FOG LIGHT switch is OFF Approximately 0 VDC when headlights are OFF or HIGH BEAMS ON +12 VDC with FOG LIGHT switch ON and headlights are ON (LOW BEAM position)
2	Red	Pin 2 to Ground	Always +12 VDC
3	Gray-White	Pin 3 to Ground	Approximately +12 VDC when FOG LIGHT switch is OFF Approximately +12 VDC when headlights are OFF or HIGH BEAMS ON 0 VDC with FOG LIGHT switch ON and headlights are ON (LOW BEAM position)
4	Red	Pin 4 to Ground	Always +12 VDC

Connector C-3

**Leave Relay connected while testing the pinouts

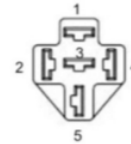

Pin	Wire Color	Test Reference	Proper Operation
2	Green Black	Pin 2 to Ground	Approximately 0 VDC when High beam switch is ON +12 VDC All other times
3	Black	Pin 3 to Ground	Aprox. +12 VDC when headlights are OFF or HIGH BEAMS ON 0 VDC when headlights are ON (LOW BEAM position)
4	Red	Pin 4 to Ground	Always +12 VDC
5	Orange-Black	Pin 5 to Ground	Approximately +12 VDC when headlights are OFF or HIGH BEAMS ON 0 VDC when headlights are ON (LOW BEAM position)

Connector C-4



Pin	Wire Color	Test Reference	Proper Operation
1	Red	Pin 1 to Ground	Always +12 VDC

Connector C-5



Pin	Wire Color	Test Reference	Proper Operation
1	Red	Connector to Ground	Always +12 VDC

Connector C-6



Pin	Wire Color	Test Reference	Proper Operation
1	Gray -White	Connector to Ground	Approximately +12 VDC when FOG LIGHT switch is OFF Approximately +12 VDC when headlights are OFF or HIGH BEAMS ON 0 VDC with FOG LIGHT switch ON and headlights are ON (LOW BEAM position)

Connector A-1, A-2

**Fog Lamp connector at bulb



Pin	Wire Color	Test Reference	Proper Operation
2	Blue Red	Pin 1 to Ground	Approximately 0 VDC when FOG LIGHT switch is OFF Approximately 0 VDC when headlights are OFF or HIGH BEAMS ON +12 VDC with FOG LIGHT switch ON and headlights are ON (LOW BEAM position)
3	Black	Pin 2 to Ground	Always continuity

Switch drill template

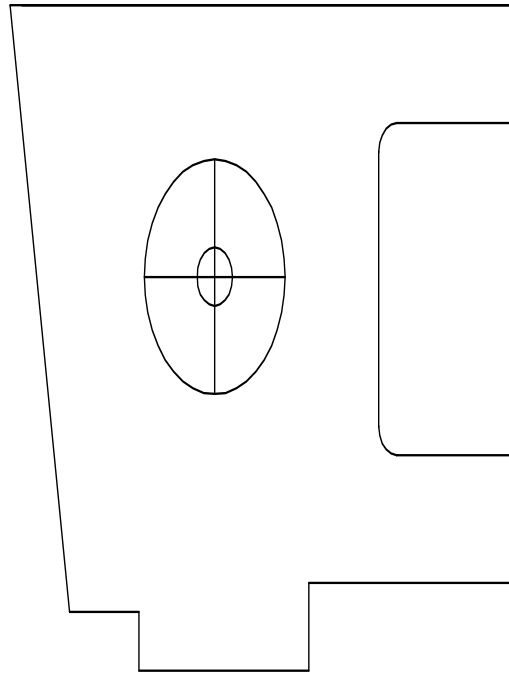

(Scale 1:1 / Actual size)