



**Installation Manual v1.0:
ATS High Capacity [Transmission Pan](#)
Ford E40D, 4R100, 5R110**

Please read all instructions before installation.

If transmission temperatures run too high, consider ATS Transmission Coolers, Thermostats and Transmission Temperature Gauges for transmission temperature control and monitoring.



Figure 1: E40D, 4R100, 5R110 ATS High Capacity Transmission Pan

1. Please make sure no parts are missing from ATS High Capacity Transmission Pan kit. A complete corresponding list of parts can be found on page 7. The bag pictured contains all hardware necessary for installation.

2. Park vehicle on level ground, apply parking brake and place transmission in **NEUTRAL**. Disconnect negative (-) battery cable(s) and secure away from negative terminal(s).
3. Position a drain pan under factory transmission to catch old automatic transmission fluid.
4. Remove transmission fluid drain plug and allow fluid to drain.

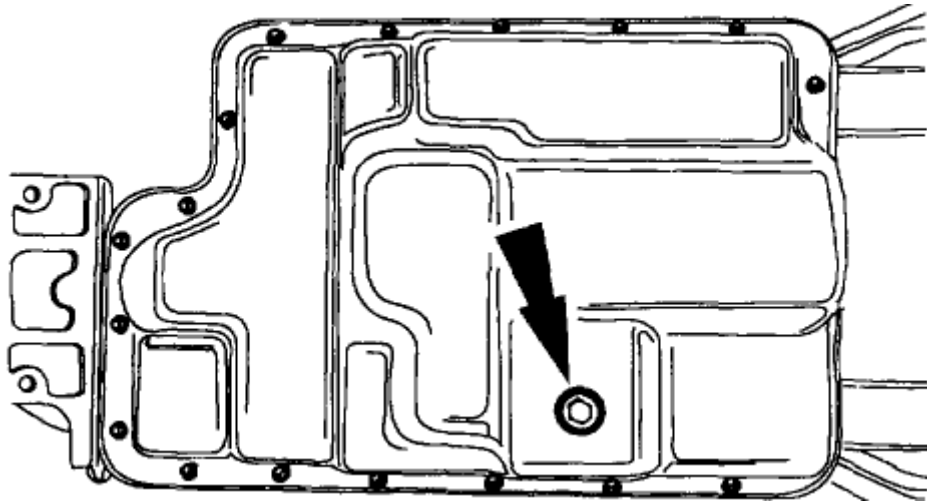

Figure 2: Ford Drain Plug Location

5. Once fluid has drained completely (fluid drips every 1 to 2 seconds) replace drain plug and remove the 20 bolts holding factory transmission pan in place. Remove pan and gasket.

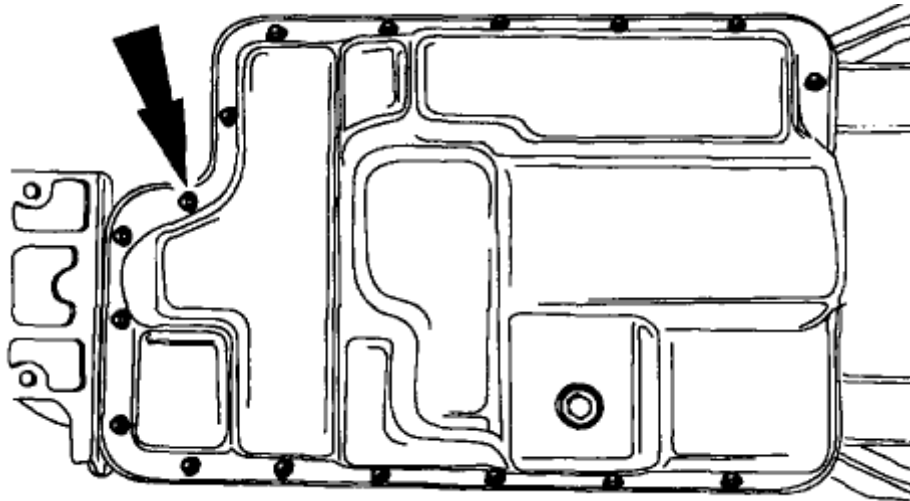

Figure 3: Ford Transmission Pan Bolt Locations

6. Remove transmission fluid filter.

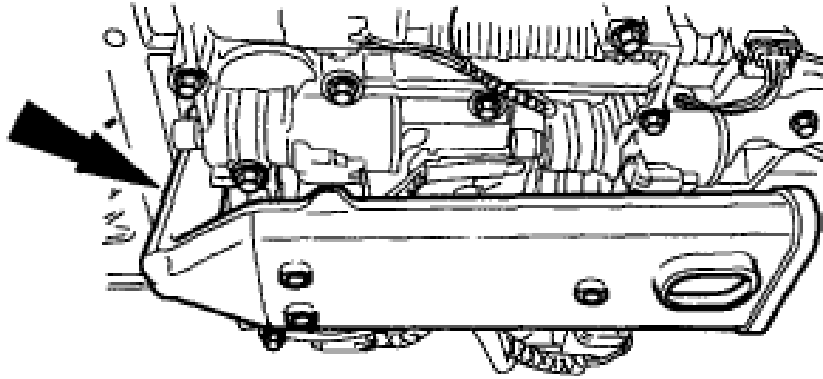

Figure 4: Ford Transmission Fluid Filter Location

7. **CAUTION:** Carefully remove transmission fluid filter seal. Damage to the seal bore will cause transmission failure. Inspect transmission fluid bore for transmission fluid seal. If seal is in bore, carefully remove seal.

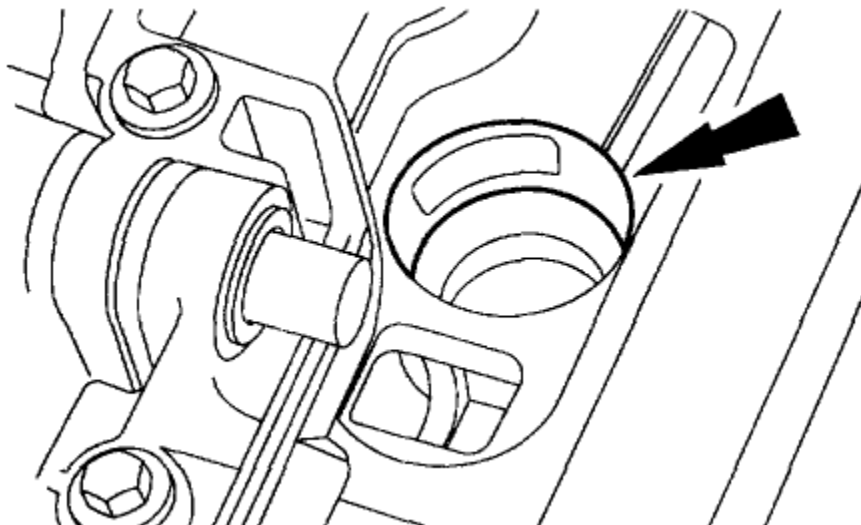

Figure 5: Transmission Fluid Filter Seal Location

8. Install a new fluid filter and seal assembly.
9. Align transmission pan gasket holes with holes in ATS High Capacity Transmission Pan. Align ATS High Capacity Transmission Pan and gasket with bolt holes in transmission. Thread new stainless steel cap screws in transmission until finger tight. Torque all cap screws to **14 ft-lbs** in a crisscross pattern.

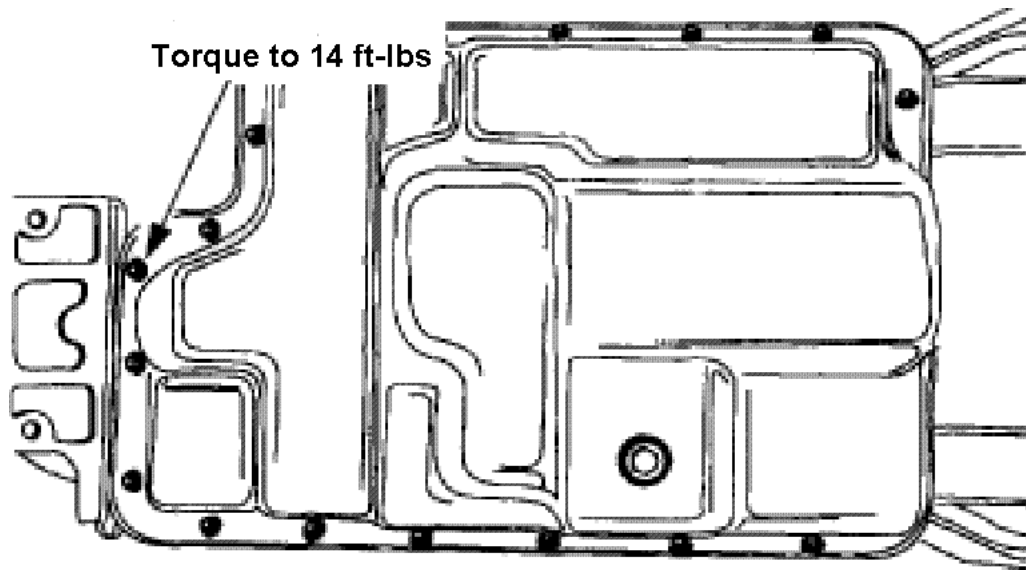

Figure 6: Torque Specifications for ATS High Capacity Transmission Pan

10. If not already installed, install drain plug and torque plug to **15 ft-lbs**.
11. If you plan to install a thermostat, install thermostat in temperature probe port located in recess on back of ATS High Capacity Transmission Pan. To install, apply anti-seize compound to threads of thermostat probe and torque probe to **10 ft-lbs**. If not, install 1/8 pipe plug with anti-seize compound in temperature probe port and torque to **10 ft-lbs**.
12. **CAUTION:** Use of any other transmission fluid than specified can result in transmission failing to operate in a normal manner or transmission failure. Refer to fluid level indicator and Owner's Guide for type of transmission fluid required. Some fluid labels may indicate dual usage such as MERCON and MERCON V. These dual-usage fluids are NOT to be used in transmissions that use only MERCON type fluid. These dual-usage fluids may be used in transmissions that require MERCON V use.
13. To fill the transmission, add approximately **12 quarts** of new automatic transmission fluid to transmission through fluid filler tube located in engine compartment of truck.
14. Reconnect negative battery cables.
15. Start engine. Move transmission range selector lever through all gear ranges, checking engagements.
16. With vehicle in **NEUTRAL**, engine running and the transmission at normal operating temperature (**150-170°F**), check and adjust the transmission fluid level, and check for any leaks. If fluid is needed, add fluid in increments of **0.25 quarts** until correct level is achieved (fluid should be cross-hatched area of fluid level indicator).

17. Pour used transmission fluid into approved container and dispose of fluid at appropriate recycling facility or participating local parts store.

A word of caution to the vehicle owner/installer:

In some applications, or because of the use of certain factory options and/or aftermarket equipment, clearance problems can occur between the ATS High Capacity Transmission Pan and other vehicle systems. It is the responsibility of the vehicle owner/ installer to ensure no other vehicle component comes in contact with the ATS High Capacity Transmission Pan. **Contact with any vehicle component, or the making of any modifications to the ATS High Capacity Transmission Pan, automatically voids the warranty. ATS Diesel Performance assumes no liability, expressed or implied, for damage or injury to persons or property.**

Bill of Materials

1. ATS High Capacity Transmission Pan 3104-301-100
2. Gasket (Axiom p/n 36300)
3. Hardware Bag
 - (20) Stainless Steel Cap Screws (M8-1.25 x 25)
 - (20) 8mm Washers (not pictured)
 - (1) 1/8 Pipe Plug
4. Magnetic Drain Plug
 - (1) Drain Plug
 - (1) O-Ring

Not Pictured:

5. Instruction Manual 3104-301-900 – INST