

**Installation Manual v1.0:  
602-920-4248:  
[Atomizer Power Module](#)  
2001-2009 GM 6.6L Duramax**

**Please read all instructions before installation.**

**Note: Seal all soldered connections with heat shrink or electrical tape**

1. Disconnect the negative battery terminals and secure the leads away from the terminals.
2. Locate the fuel rail pressure sensor and connector.
  - a. For 2001-2004 LB7 engines, the fuel rail pressure sensor is located in the junction block between the fuel rail assemblies.
  - b. For 2004.5 and later engines, the fuel rail pressure sensor is located in the passenger side fuel rail.

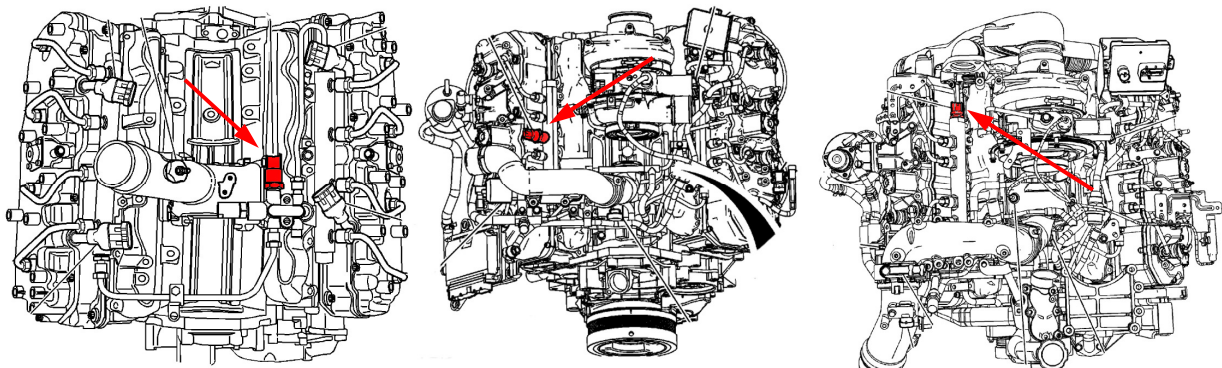

**Figure 1 - Rail Pressure Sensor Locations.  
LB7 (left), LLY (center) and LBZ/LMM (right)**

3. Remove the rail pressure sensor connector from the sensor. Plug the Atomizer harness into the rail pressure sensor and plug the factory harness into the other connector in that portion of the harness.

**NOTE:** Be sure to orient the rail pressure sensor connectors as show below. There is a ramp and clip that must be connected properly. The block on the opposite side will then slide into the slot of the opposing connector. If reversed, the truck will not idle properly and the engine will likely shut off.

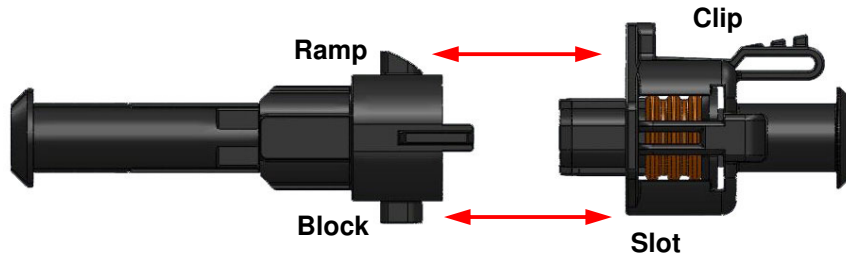

**Figure 2 - Rail Pressure Sensor Connector Orientation**

4. Locate the manifold absolute pressure (MAP) sensor.

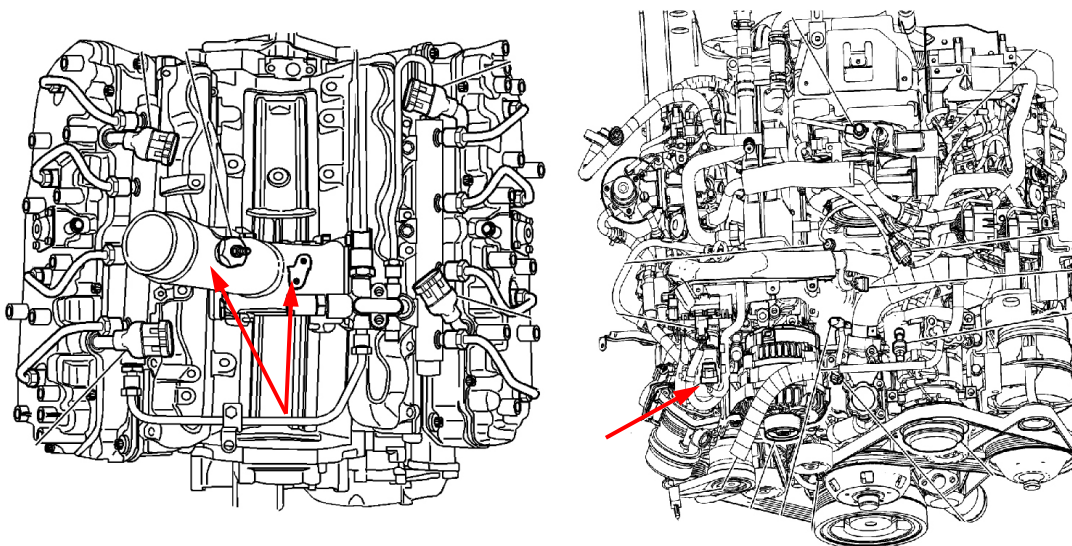

**Figure 3 - MAP Sensor Locations. LB7 (left) and LLY/LBZ/LMM (right)**

5. Remove some of the wire shroud from the MAP sensor wires to expose the wires that run into the MAP sensor connector.
6. The Atomizer can also serve as a Boost Fooler to eliminate overboost codes when using aftermarket turbos. If Boost Fooler functionality is also desired, see step 7. If not desired, tap the green wire into the light green wire (pin B) and skip step 7.
7. To wire the MAP sensor connections, cut the light green wire 4-5 inches from the connector. Solder the green wire from the Atomizer to the

- connector side of the light green wire in the MAP sensor harness. Solder the orange wire from the Atomizer to the ECM side of the light green wire
8. Installation can be completed in two different ways. If adjustability is desired, follow steps 9-16. If maximum performance is desired all the time, leave the pink wire unterminated, secure it away from any other electrical connections and skip to step 17.
  9. Find a suitable location either under the hood or in the passenger compartment to install the variable switch. A bracket is included with kit and can be used to mount the switch on top of the dash, under the dash or wherever desired. The switch can also be mounted directly in the dash. For this option, a 3/8" hole will have to be drilled. If drilling in the dash, take care not do damage any wiring or other components inside the dash.
  10. Once a location is found, remove the control knob using a 1/16" allen wrench and remove the nut and lock washer from the switch.
  11. Apply the Atomizer switch sticker around the mounting hole, where it will be visible and in the desired orientation.
  12. Locate the black wire on the variable switch and connect it to a good ground using the ring terminal provided.
  13. Route the pink wire from the Atomizer harness to the location of the switch. Connect the wires using the connectors provided.
  14. Secure the switch in the bracket or dash using the lock washer and nut.
  15. Turn the switch to the full, counter-clockwise position. Reinstall the control knob on the switch with the indicating line pointing to the "0%" on the sticker.
  16. Verify the switch is set to the lowest setting (turned fully counter-clockwise) and start the vehicle.
  17. Reconnect the negative battery terminals.
  18. Test-drive the vehicle to verify drivability and that the vehicle does not display a check engine light. If a check engine light is set, check the wiring to verify good connections.
  19. When proper operation is verified, it is ok to increase the levels as desired.
  20. Test-drive the vehicle to verify drivability and that the vehicle does not display a check engine light. If a check engine light is set, check the wiring to verify good connections.

21. When proper operation is verified, it is ok to increase the levels as desired.

**WARNING:** If the Atomizer is used in conjunction with other performance electronics, it is possible to increase rail pressure to dangerous levels. ATS is NOT liable for damage to fuel injection components in the event that rail pressure is increased beyond safe limits. It is important ensure rail pressure does not exceed safe limits (27,500psi).



Atomizer Wiring Diagram v1.0  
01-09 GM 6.6L Duramax

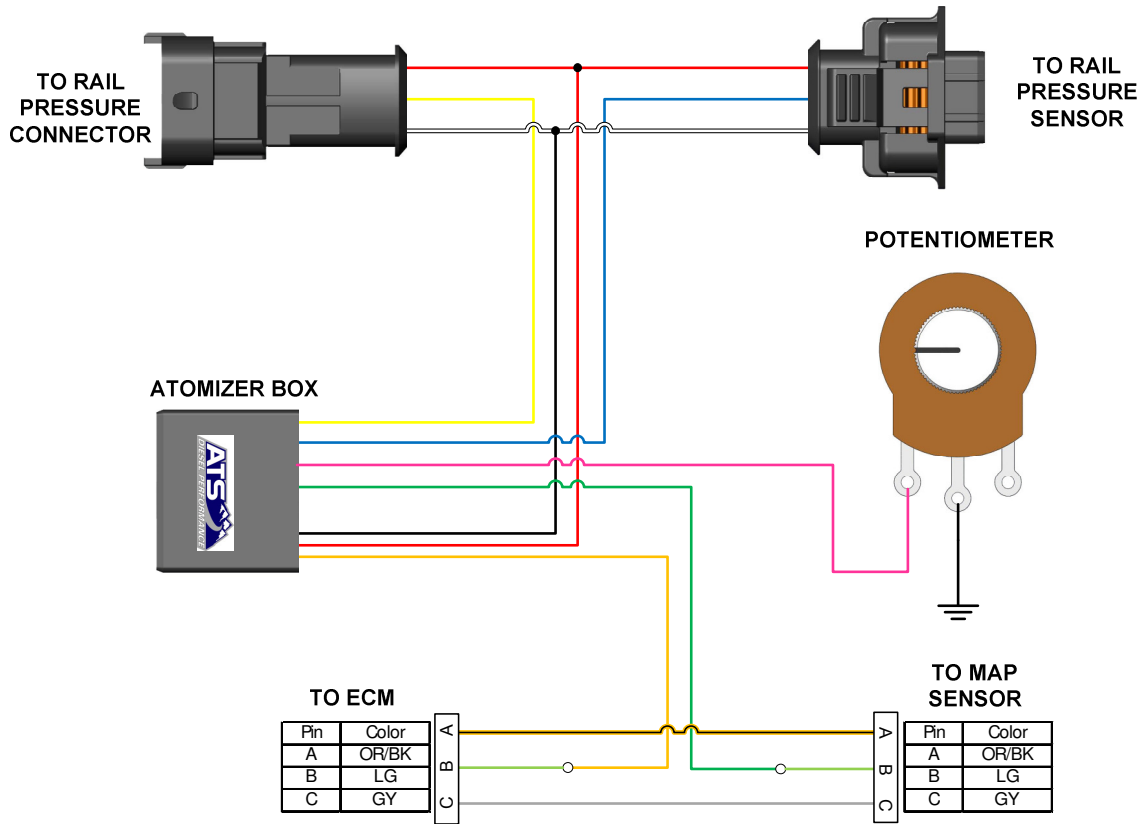

## **Bill of Materials**

1. Atomizer Electronics and Harness 601-120-4248
2. Atomizer Variable Switch 3852A-282
3. Atomizer Switch Bracket
4. Atomizer Sticker
5. (4) 18-22 Butt Connector
6. (4) Piece of 1/8" Heat Shrink Tubing
7. #10 18-22 Ring Terminal IRR10
8. Instruction Manual 602-920-4248-INST