

ARTEC INDUSTRIES JL FENDER SUPPORT BRACKET

Thank you for your purchase of our JL front fender support bracket.



**TYPICAL INSTALL
TIME: 2.0 hour**

Bill Of Materials

ITEM NO.	PART NUMBER	DESCRIPTION	QTY.
1	JL2112-LASER	JL FRONT FENDER BRACE KIT - LASER CUT COMPONENTS	1
2	HW0092	1/4"-20 x 1/2 Button Head Socket Cap Screw Zinc Plated	4
3	HW0018	1/4"-20 Nylon Insert Hex Lock Nut Zinc	4
4	HW0033	1/4" USS (TYPE A WIDE) Flat Washer Zinc	4
5	OZ1601	LED Bolt Light -1 watt, Amber, Aluminum, 16mm, Silver	4

REQUIRED TOOLS

- 8mm & 10mm Socket
- T25 & T30 Torx
- 5/8" Drill Bit
- 1/8" Drill Bit
- Power Drill
- Philips Screw Driver

STEP 1. Unpack contents of shipment. Make sure that all of the parts required are included with your kit. If any items are missing, and packaging is damaged, report it to the shipping company driver, **KEEP ALL ORIGINAL PACKAGING & contact us.**

STEP 2. First start by parking the vehicle on level ground and applying the parking brake. Start by drilling out the center of the 8 plastic rivets securing the inner fender. They are located towards the outside of the fender. Next remove the 7 plastic push in clips. Finally remove the 8mm bolt and 10mm bolt. You can now remove the inner fender from the fender assembly to gain access to the rest of the fender.

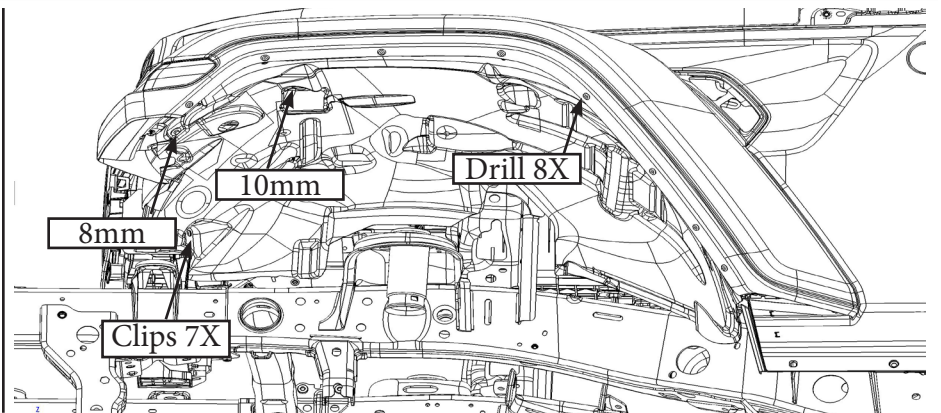

STEP 3. Next we start on the removal of the factory fender light housing. Remove the bottom shield by removing the phillips bolt, 8mm bolt and 10mm bolt. Next remove the the 3 T30 torx bolts retaining the brace behind the light. You can now access the light housing, unplug and remove wiring from the flare. Remove the T30 bolt retaining the reflector assembly. Also remove the 4 T25 bolts retaining the light housing. The light housing has adhesive on the front so gently pull and remove it from the fender.

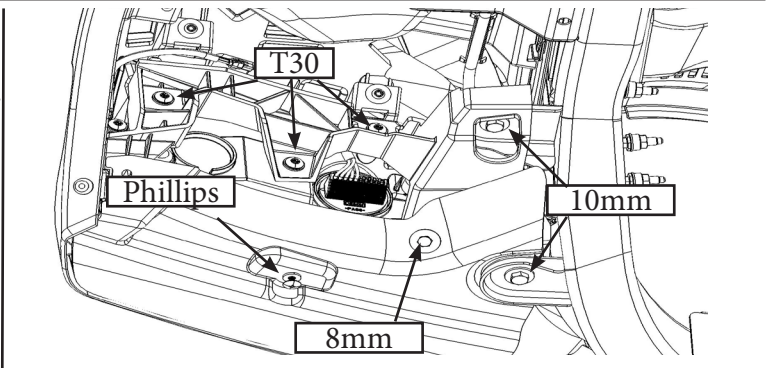

NOTE: THIS KIT INVOLVES VEHICLE MODIFICATION AND MECHANICAL SKILLS. IF YOU ARE NOT CONFIDENT IN YOUR SKILLS, CONTACT A PROFESSIONAL INSTALLER.

STEP 4. Next we will remove the rear fender flare support pieces. Using a pair of dikes cut the rivets and clip holding these brackets in, they can now be removed. Now the fender flare can be removed from the vehicle. Using needle nose pliers, carefully pinch the tangs and pop out the clips holding the fender on. These clips can be reused later to re-attach the fender or you can opt to use hardware for a more secure install.

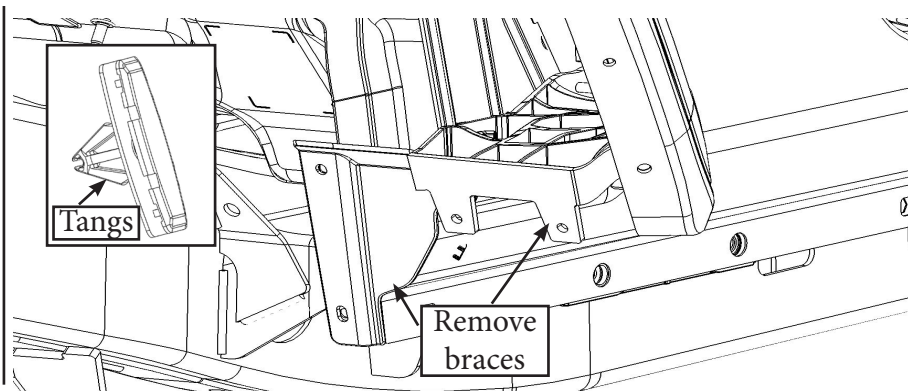

STEP 5. Next is to remove the internal fender structure, it is attached with adhesive so carefully pull and separate it from the fender flare. Next we can remove the secondary part of the fender flare. Remove the clip in the front of the flare. Next carefully separate the secondary fender components from the flare assembly.

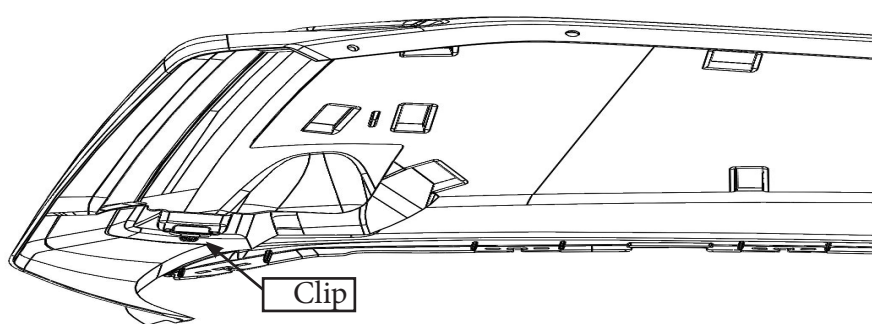

STEP 6. Before re-installing the fender onto the jeep, trim off the tabs that once held the fender together. Next either using the clips we removed in step 4 or the optional hardware, re-install the flare. Also trim off the tab on the front of the fender flare that is closest to the body of the jeep.

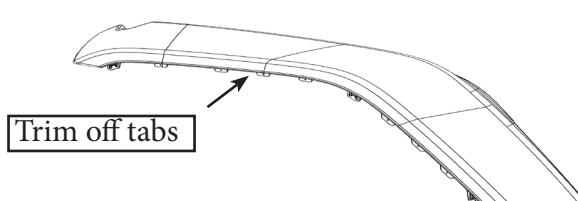

STEP 7. Next loosely install the fender support bracket, on the inside of the flare mark the center of the light location. Remove the bracket and drill a pilot hole from the inside of the fender flare. Now using a 5/8" bit, drill from the outside of the flare using the pilot as reference. Re-install the bracket and tighten down the hardware.

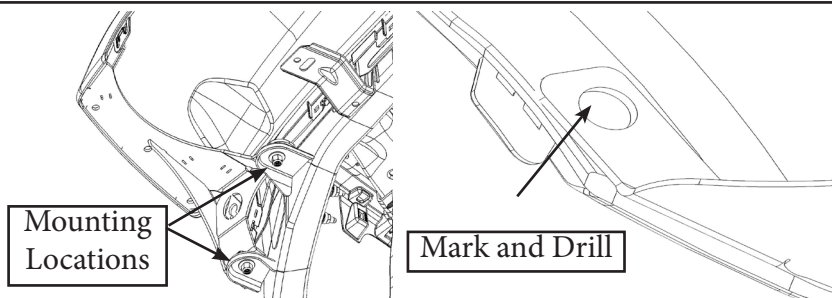

STEP 8. Finish by installing and wiring the provided lights. Utilize the zip tie slits in the bracket to secure the wiring. Perform all the above steps to the passenger side of the vehicle as well to complete the install. We recommend using our inner fenders to provide a finished look and keep contaminants out of the engine bay.

Turn Signal	Marker Light
White Wire W/ Green Stripe	White Wire W/ Brown Stripe

**Artec Industries, LLC is not responsible or liable for improper installation of this kit. Use common sense when installing.

NOTE: THIS KIT INVOLVES VEHICLE MODIFICATION AND MECHANICAL SKILLS. IF YOU ARE NOT CONFIDENT IN YOUR SKILLS, CONTACT A PROFESSIONAL INSTALLER.