



# ATD-8696

## 4 IN 1 BALL JOINT SERVICE TOOL SET

### OWNER'S MANUAL

#### **WARNING: TO HELP PREVENT PERSONAL INJURY**

- Always wear ANSI approved goggles when using this product. Normal use of this product is likely to expose the user to dust and/or microscopic particles containing chemicals known to the State of California to cause cancer, birth defects or other reproductive harm. Always wear appropriate safety equipment and clothing when using this product.
- Study, understand, and follow all instructions provided with this product.
- Before repairing vehicle, block the wheels to prevent the vehicle from moving.
- Check the final alignment of the C-frame press and all tooling with components before exerting pressure to remove or replace a ball joint.

#### **OPERATING INSTRUCTIONS**

##### **Brake Anchor Pin Removal and Installation**

1. Remove all lock ring retainers from the brake anchor pins.
2. Position the C-frame press over the brake spider as shown in Figure 1.
3. Tighten the forcing screw until the anchor pin is removed.

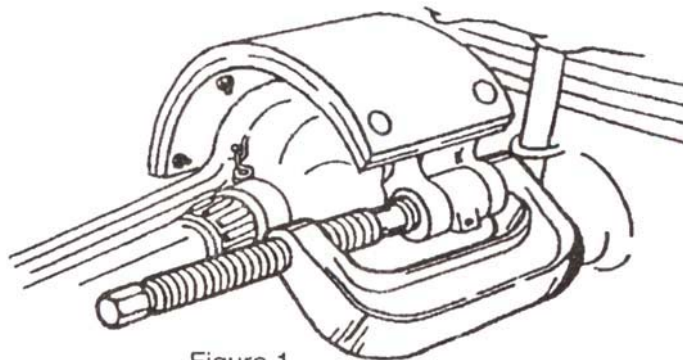

Figure 1

##### **"U" Joint Assembly And Disassembly**

The basic C-frame press is used to service the "U" joints on most cars and light trucks.

The "U" joints can be serviced either on or off the vehicle.

### Disassembly

1. Remove any external and/or internal lock rings.
2. Position the C-frame press around the drive shaft yoke, and tighten the forcing screw until the first bearing is removed.
3. Reposition the C-frame and remove the second bearing.

### Assembly

1. Clean all dirt and oil from the yoke area.
2. Align the replacement bearing and C-frame press as straight as possible over the yoke. Press the replacement bearing into the yoke, and reassemble the external / internal lock ring.
3. Reposition the C-frame press and second replacement bearing as straight as possible over the yoke, and press the bearing into the yoke. Reassemble the external / internal lock ring.

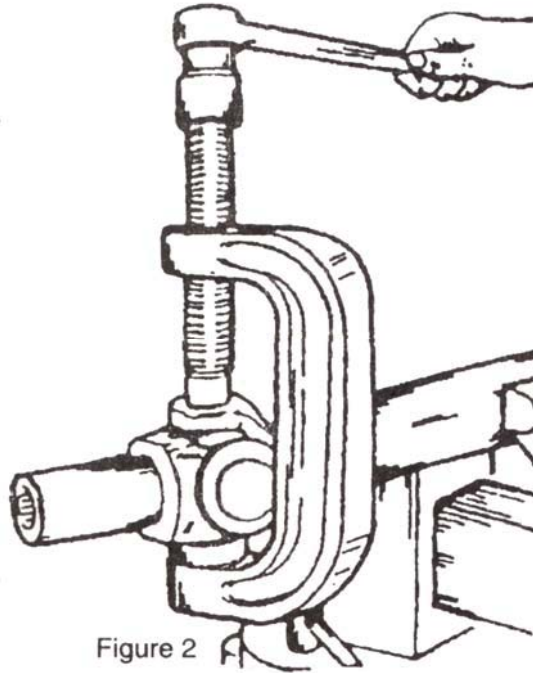

Figure 2

### Ball Joint Removal and Installation

This tool set is designed for use on all cars and light trucks that have press-fit type ball joints without the need to remove the control arm from the vehicle.

**NOTE: Some cars and light trucks may have the upper ball joint spot-welded to the control arm. The weld must be cut before attempting to remove the ball joint.**

### Removal

1. Assemble the ball joint press over the control arm as shown in Figure 3. Select the correct size receiving tube (Item 6, 7, or 8), and position it under the vehicle ball joint; refer to Figure 3.

2. Tighten the forcing screw until the receiving tube contacts the control arm. Check the alignment of all tooling and components, and continue tightening the forcing screw until the ball joint is removed.

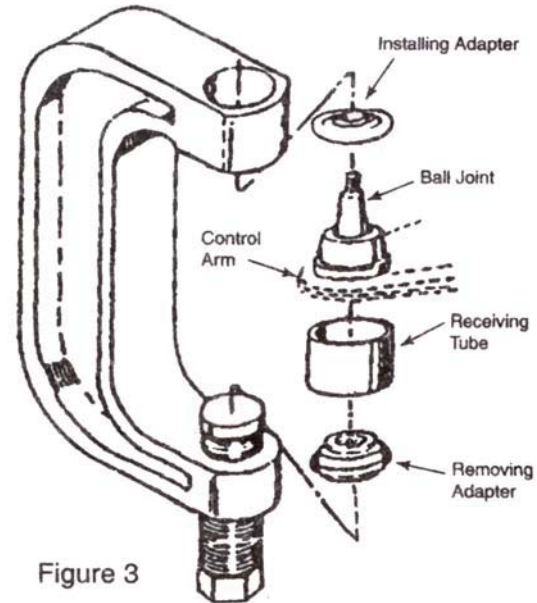

Figure 3

### Installation

1. Clean the control arm and coat the I.D. with a suitable lubricant.
2. Insert the replacement ball joint as straight as possible into the vehicle control arm.
3. Assemble the ball joint press component as shown in Figure 4. Position the receiving tube, and tighten the forcing screw. Check the alignment of all tooling and components, and continue tightening the forcing screw until the ball joint is firmly seated.

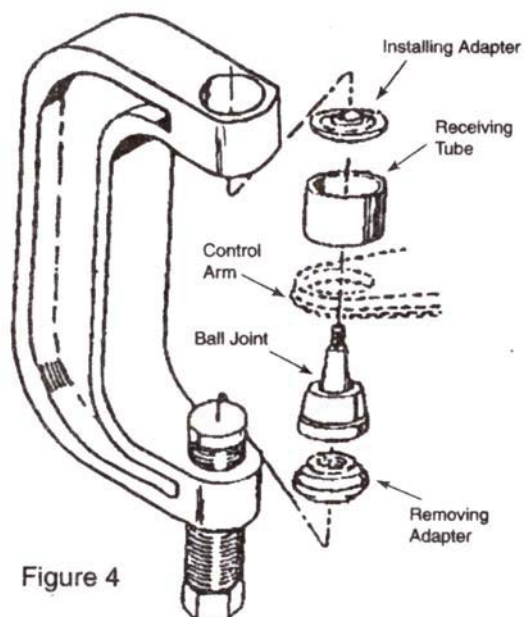

Figure 4



# ATD-8696



1

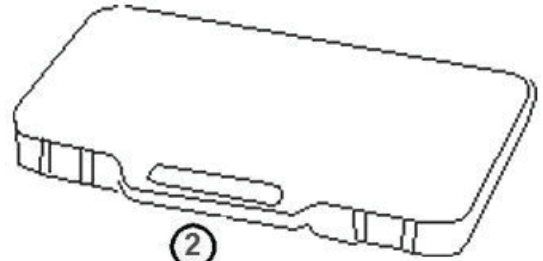

2



3



4



5

Receiving Tubes



6

1-3/4" x 2"

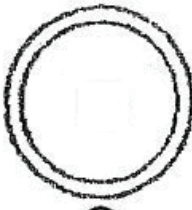

7

2-3/4" x 2-1/2"

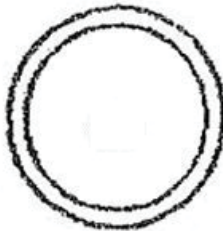

8

2-1/4" x 3"

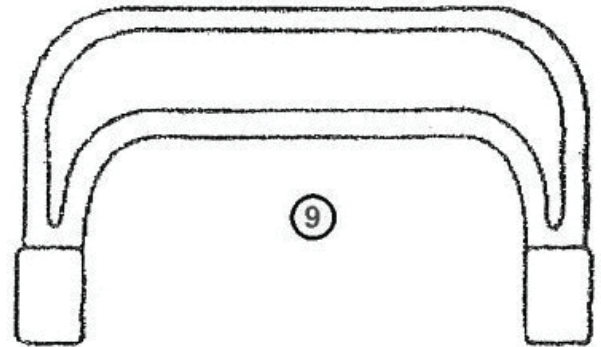

9



10



11

ITEM#	ORDERING PART#	PART DESCRIPTION
1	PRT8696-1	SCREW
2	PRT8696-2	BLOW MOLDED CASE
3	PRT8696-3	INSTALL ADAPTER
4	PRT8696-4	INSTALL CUP ADAPTER
5	PRT8696-5	RECEIVING CUP
6	PRT8696-6	1-3/4" x 2" RING
7	PRT8696-7	2-3/4" x 2-1/2" RING
8	PRT8696-8	2-1/4" x 3" RING
9	PRT8696-9	C-FRAME 6.25" x 2.25" (ON CENTER)
10	PRT8696-10	REMOVAL ADAPTER
11	PRT8696-11	INSTALL CUP