



ATD-8645

58:1 Torque Multiplier Wheel Nut Wrench Owner's Manual



SPECIFICATIONS:

Model Number: ATD-8645
Output Drive: 1" sq (male)
Ratio: 58:1
Maximum Rated Output: 4000 Nm (2,950 ft. lbs.)



WARNING: This product contains chemicals, including lead, known to the State of California to cause cancer, birth defects or other reproductive harm. **Wash hands after handling.**

General Safety Warnings:

The instructions and warnings contained in this manual should be read and understood before using or operating this tool. Do not allow anyone to use or operate this tool until they have read this manual and have developed a thorough understanding of how this tool works. Failure to observe any of the following instructions could result in severe personal injury to tool user and bystanders, or cause damage to the tool and property. Keep this manual for future reference.

 **Note:** The warnings and cautions discussed in this instruction manual cannot cover all possible conditions and situations that may occur. It must be understood by the operator that common sense and caution are factors which cannot be built into this product, but must be supplied by the operator.

- Use safety equipment. Users and bystanders should use safety goggles or safety glasses with side shields which comply with current national standards. This applies to all persons in the work area. Also use skid safety shoes, hardhat, gloves and hearing protection when appropriate.
- Keep bystanders and children out of the work area while operating this tool.
- Always keep your work area clean, uncluttered, and well lit. Cluttered or dark areas invite accidents and injuries. DO NOT work on floor surfaces that are slippery.
- Do not operate this tool if you are tired or under the influence of alcohol, drugs or medications that could affect your ability to use the tool properly.
- Dress properly. Do not wear loose clothing or jewelry as they can be caught in moving parts. Wear restrictive hair covering to contain long hair.

ATD-8645 Specific Safety Warnings:

- Ensure the torque multiplier is in sound condition and good working order. Take action for immediate repair or replacement of damaged parts.
- **DANGER: DO NOT** support the vehicle on a jack; use suitably rated axle stands under the vehicle before proceeding with wheel removal/replacement.
- **DO NOT** allow untrained persons to operate the torque multiplier.
- **DO NOT** work under the vehicle until axle stands have been positioned correctly.
- **DO NOT** use the torque multiplier for any purpose other than that for which it is intended.
- **DO NOT** use over 44 lbs (20 kg) of force. May result in damaging threads or even breaking the bolt due to too much force.
- Keep the torque multiplier clean for best and safest performance.
- Keep work area clean and tidy and free from unrelated materials.
- Ensure the work area has adequate lighting.
- The vehicle to be worked on should be on level and solid ground only, preferably concrete.
- Place wedges under wheels of vehicle.
- Ensure that the vehicle's engine is switched off.
- Ensure the vehicle handbrake is applied and 1st gear engaged.
- Check that there is a minimum of 0.5m between the vehicle and static objects such as doors, walls, etc. to allow for vehicle tilting when jacked up.
- Ensure all non-essential persons keep a safe distance whilst the vehicle is jacked up.
- Ensure there is no one in the vehicle that is to be jacked up.
- Use care if using on aluminum, chrome or finished wheels or parts. Tool may scuff or damage the surface.
- Store torque multiplier in a dry, childproof area when not in use.

ATD-8645 Contents:

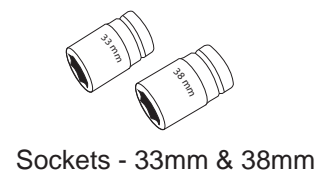
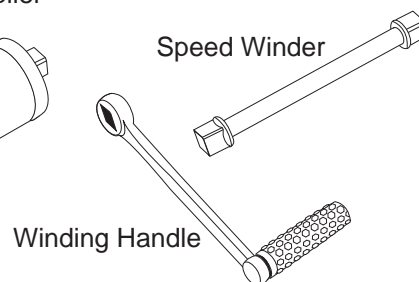
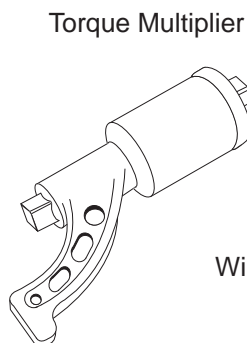
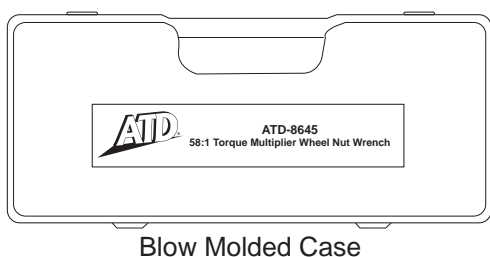



ATD-8645 Operation Instructions

- Assemble the torque multiplier as in fig.1, placing the correct size 1" drive socket on the working end of the torque multiplier.
- Place the multiplier onto the first of the wheel nuts to be undone as shown in fig.2(A).
- When turning a nut clockwise the reaction leg will react in an counter-clockwise direction and vice-versa. The reaction leg must be butted up against a solid object (adjacent wheel nut, wheel rim or hub) to resist the rotation of the leg as in fig.2(B). **NOTE:** Some commercial vehicles may have left hand threads on wheel studs and nuts; check which direction is required.
- To spin a loose nut in either direction quickly use the speed winder and the winding handle as shown in fig.1.
- The final tightening of the wheel nuts should be carried out using a suitable torque wrench set to the recommended values shown in the manufacturer's handbook. **NOTE:** It is our policy to improve products continually and as such we reserve the right to alter data, specifications and component parts without prior notice.

IMPORTANT: No liability is accepted for incorrect use of this product.

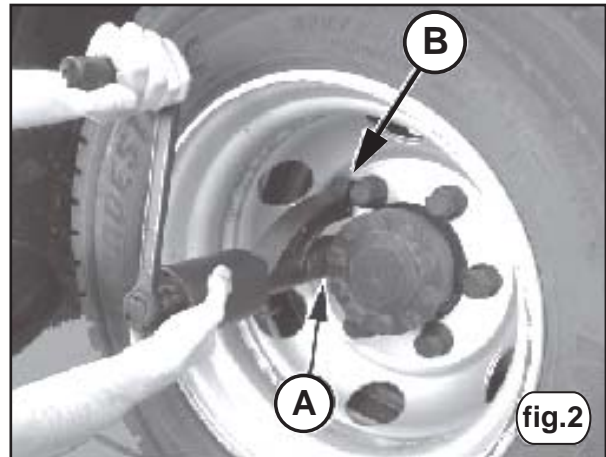
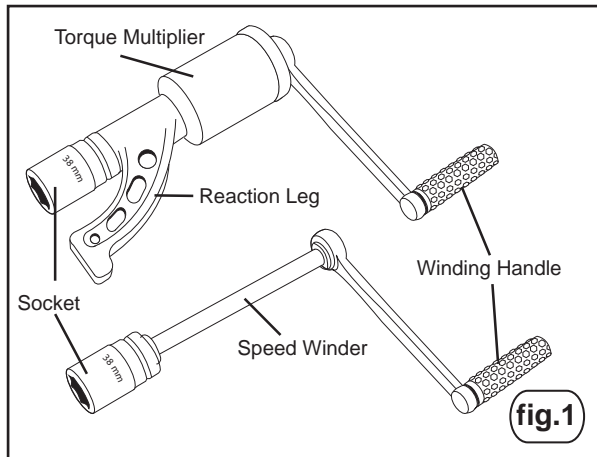



ATD-8645

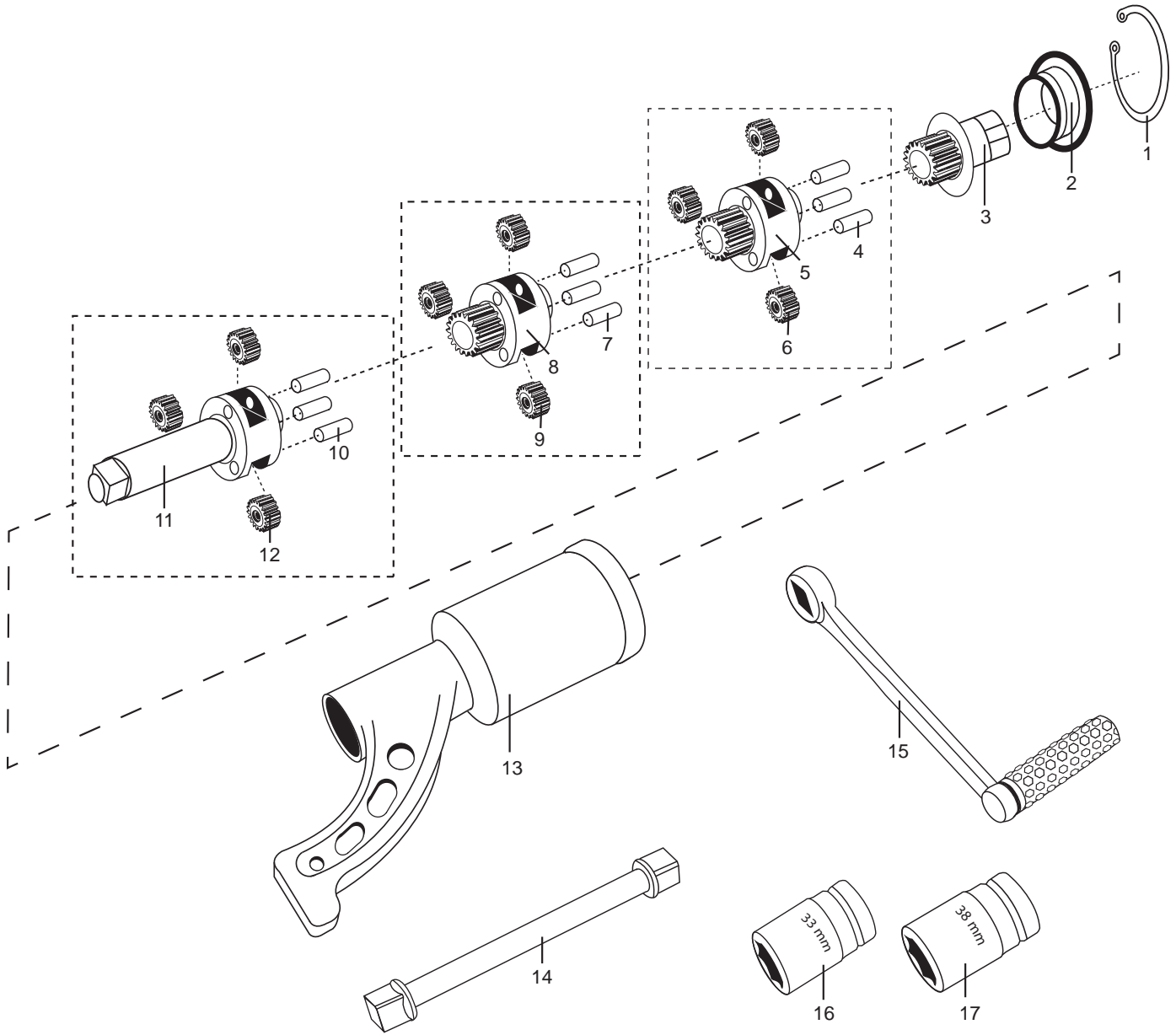

ITEM#	ORDERING PART#	PART DESCRIPTION
14	PRT8645-14	SPEED WINDER
15	PRT8645-15	WINDING HANDLE
16	PRT8645-16	SOCKET, 33MM
17	PRT8645-17	SOCKET, 38MM
N/S	PRT8645-18	BLOW MOLDED CASE

* - ITEMS 01 - 13 ARE SHOWN FOR REFERENCE ONLY
THEY ARE NOT AVAILABLE SEPARATELY