



# MANUAL

## Foldable Topside Creeper Model ATD-8116F



Please read and understand all safety advisories and operating instruction in this manual to ensure safe and productive operation of your new Topside Creeper.

# Safety First

**WARNING:** Failure to follow these safety requirements could result in personal injury.

This product is a tool to reach what are normally hard to reach places, such as the topside of an engine compartment for mechanics.

Always inspect the product for damage before each use. Do not use if damage is detected.

Make sure all nuts and bolts are secure before each use.

Always engage the caster locks before using the Topside Creeper.

Always make sure the angle adjustment bar is secure in one of the three position slots before using.

Always face the Topside Creeper when climbing up or down. Use both hands and keep your body centered between the rails.

DO NOT USE THE PRODUCT if you tire easily or are subject to fainting spells or disorientation.

DO NOT USE THE PRODUCT if you are taking medication that could impair judgement.

DO NOT USE THE PRODUCT if you are under the influence of drugs or alcohol.

DO NOT USE THE PRODUCT if you are physically challenged.

DO NOT sit or stand on the chest pad.

DO NOT overload the product. The maximum capacity is 400 lbs (180 kg) which includes body weight, tools and torque applied to tools.

DO NOT use the Topside Creeper over a running engine.

# Operating Instructions

## Using the adjustable angle lean-in feature

There are three different lean-in angles that allow the user to adjust positioning. This helps the user to maximize safety and productivity. To adjust angle lean-in:

1. Lock casters (A2) by pressing the lock tab with your foot on each of the locking casters.
2. Push back on the climbing section (O).
3. Move angle adjustment to one of the three notches located on the base.

## Changing Working Height

The working height of the Topside Creeper can be adjusted to fit the needs of each individual task from 44" (110cm) to 68" (172cm) in height. To change the working height:

1. Lock casters (A2) by pressing the lock tab with your foot on each of the locking casters.
2. Grasp a step within the sliding section with one hand while using the other hand to pull one of the spring loaded locking pins outward. Rotate the pin so it does not slide back into the locking slot.
3. Repeat step 2 on the other side of the sliding section to remove the second spring loaded locking pin. **IMPORTANT:** one hand **MUST** have a firm hold of a step within the sliding section when the second spring loaded locking pin is removed from the locked position. This prevents the sliding section from free falling which could cause serious personal injury.
4. Slide the inside step section up or down to desired height while maintaining a firm grip.
5. While holding a step within the sliding section with one hand guide one of the spring loaded locking pins into its corresponding hole in the outside rail.
6. While maintaining a firm hold on the sliding section, move it up or down as needed and until the spring loaded locking pin springs into one of the oval shaped height adjustment holes located in the side rails of the sliding section.
7. Guide and insert the second spring loaded locking pin through both the outside rail and oval shaped hole of the inside sliding section rail.

## Folding the base section

The foldable Topside Creeper features a folding base section to allow for convenient and compact storage. To fold the Topside Creeper:

1. Lock casters (A2) by pressing the lock tab with your foot on each of the locking casters.
2. Remove two locking pins from the assembled base section.
3. Push the angle adjustment bar forward to the first setting of the notched angle adjustment keeper on the Topside Creeper base.
4. Grasp each of the two legs (M1 and M2) and raise up to the climbing section.
5. Replace the pins back into their holes for safekeeping.

# Parts And Hardware

A1 - Front Caster x 2  
(ATD-10238R)



A2 - Locking Caster x 2  
(ATD-10237)



B - 18mm Flange Nut x 4



C - 19mm Lock Nut x 4



D - 8mm Lock Nut x 8



E - 10mm Lock Nut x 6



F - 2.5" x 19mm Bolt x 4



G1 - 3" x 14mm Bolt x 2



G2 - 9/16" x 14mm Bolt x 6



G3 - 1/2" x 10mm Bolt x 4



H - 5/8" x 6mm Phillips Screw x 4



I - Pin x 2



J - Square Tube



M1 - Right Leg



M2 - Left Leg



K - Base



O - Step Section



N - Angle Adjustment Keeper x 2



L - Chest Pad Frame



P - Chest Pad  
(910993)



S - Pouch Bracket



R - Pouch



U - Bumper Pad x 3



Q - Washer x 2

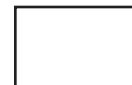

## ASSEMBLY INSTRUCTIONS

Tools Needed : 12mm wrench, 8mm socket  
6mm wrench, philips screwdriver

## BASE ASSEMBLY

Assemble legs (M1 & M2) to Base (N) using Bolts (F), Nuts (C) and Pins (I) as shown. Do not overtighten.  
**NOTE:** The two legs must be angled outward with angle adjustment notches positioned to the inside.

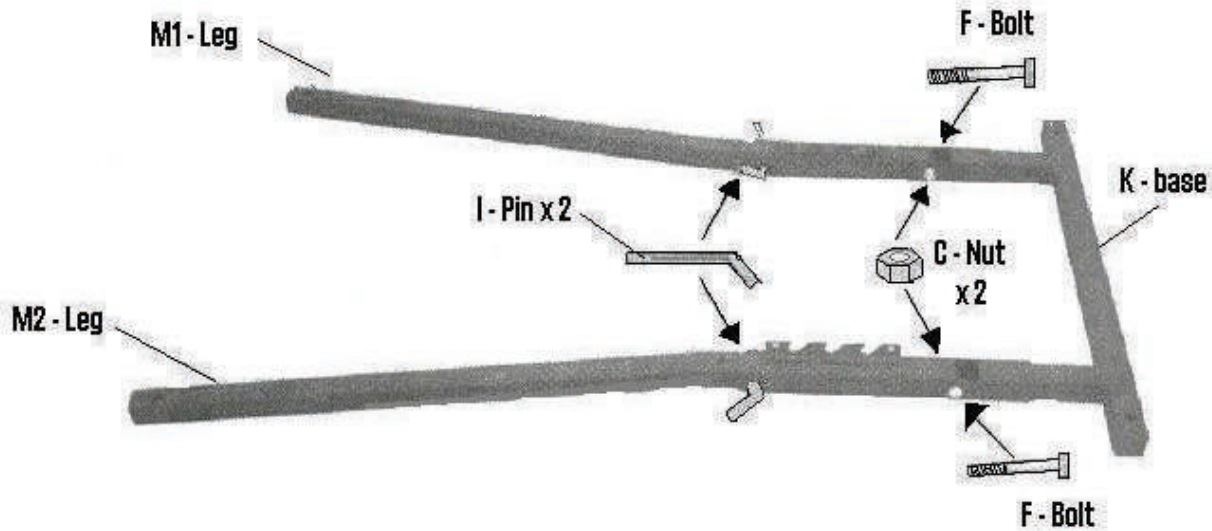

## CASTER ATTACHMENT

With angle adjustment notches upward, secure two Locking Casters (A2) to closed end of base (N) using Flange Nuts (B). Secure two non-locking casters (A1) to the outward protruding legs using Flange Nuts (B) as shown.

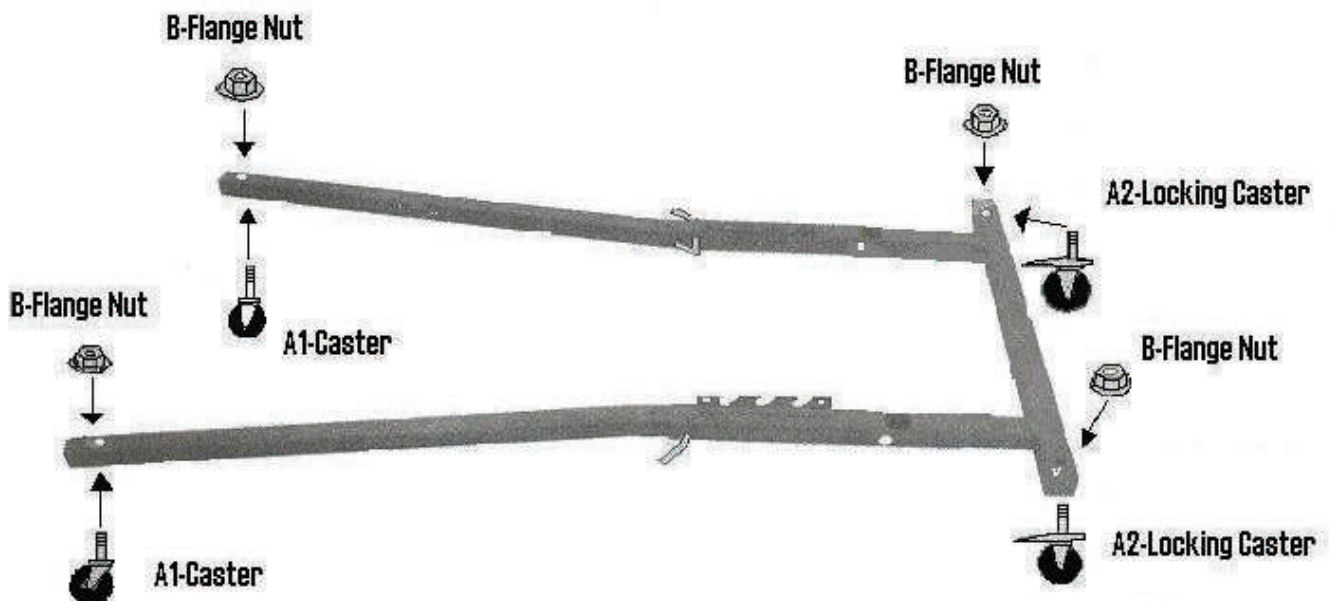

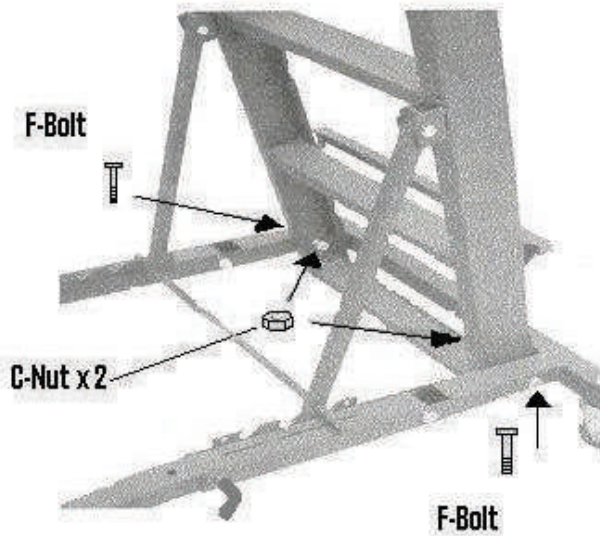

## SECURE CLIMBING SECTION TO BASE SECTION

**IMPORTANT:** Inside step section must be secured before proceeding. Insert both spring loaded adjustment pins into corresponding hole in outside rail of Climbing Section (M). Slide inside step section frame until both spring loaded adjustment pins fully engage through oblong adjustment holes of inside rails.

Position step section (O) as shown. Secure step section to base using two Bolts (F) and two Locknuts (C).

## SECURE ANGLE ADJUSTMENT KEEPERS

Place angle adjustment bar into one of the three adjustment slots located on the base. Secure Angle Adjustment Keepers (N) to base using Bolts (G3) and Lock Nuts (E).

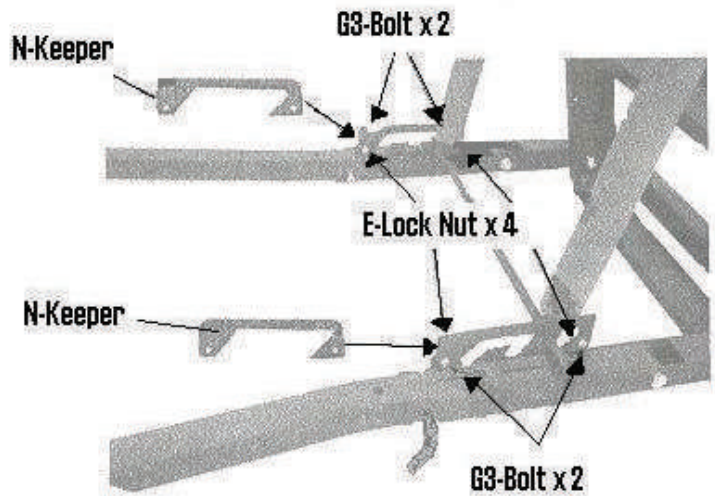

## ATTACH BASE CROSS BAR SUPPORT

Using two Bolts (G1), two Nuts (D) & washers (Q) attach Square Tube cross bar support (J) to base as shown.

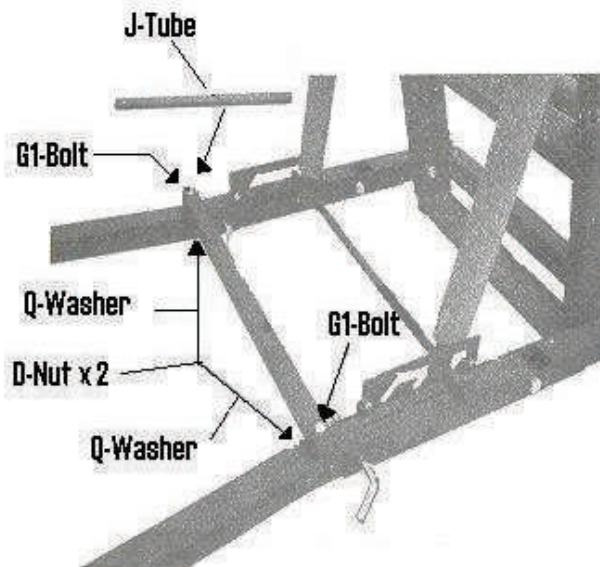

## ATTACH CHEST PAD FRAME

Using Bolts (G2) and Nuts (D) secure chest frame to climbing section as shown.

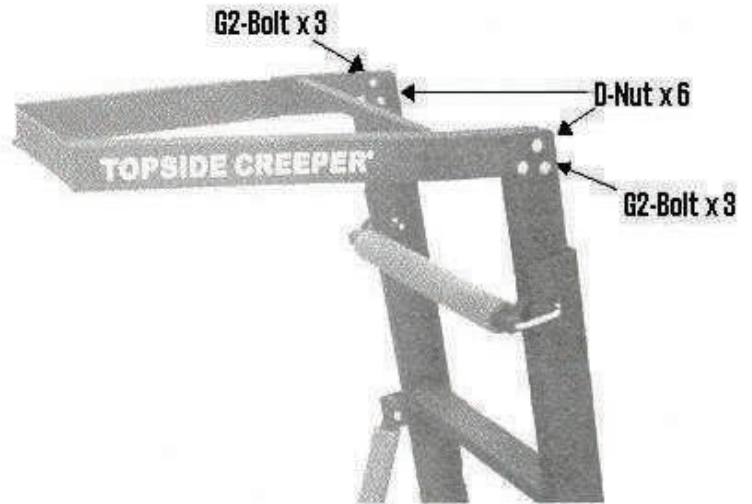

## S-Pouch Bracket

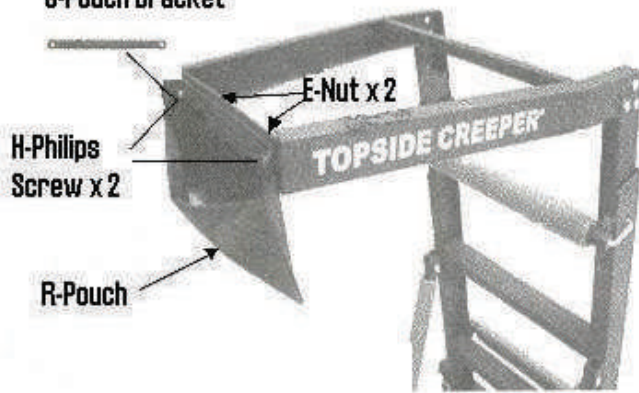

## ATTACH TOOL POUCH

Insert Philips Head Screws (H) through Bracket (S), Pouch (R) and Chest Pad Frame as shown. Secure to frame using lock Nuts (E).

## ATTACH CHEST PAD

Using two philips head bolts (H) secure chest pad to chest pad frame by inserting through holes in bottom of frame and into threaded inserts in bottom of pad.

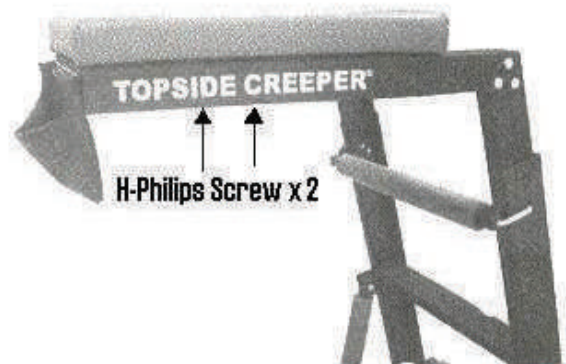

**ATTACH BUMPER PADS** To angle adjustment bars and adjustment pin cross bar as shown

