



ATD-7440 2-Ton Heavy-Duty Tripod Stand Owner's Manual



Features:

- Underhoist stand is perfect for use with 2 or 4 post lifts
- Heavy gauge steel frame prevents distortion or twisting
- High reach supplementary stand prevents tipping and rocking of vehicle
- This stand is NOT designed to support the vehicle
- Meets or exceeds ASME / PASE 2014 standards

Specifications:

- Capacity: 2 Ton
- Minimum Height: 69"
- Maximum Height: 78-1/2"
- Saddle Size: 5-1/4" x 1-1/2"
- Base Size: 24" x 22-1/2"

SAFETY and GENERAL INFORMATION

Save these instructions. For your safety, read, understand, and follow the information provided with and on this high reach supplementary stand before using. The owner and/or operator of this equipment should have an understanding of this product and safe operating procedures before attempting to use. Before attempting to position this device, the owner and/or operator should be aware that using the product requires special skills and knowledge pertaining to working on, under, and around a vehicle with an automotive lift. Instructions and safety information should be conveyed in the operator's native language before use of this stand is authorized. If any doubt exists as to the safe and proper use of this high reach supplementary stand as outlined in this factory authorized manual, remove from service immediately.

Inspect before each use. Do not use if broken, bent, cracked, or damaged parts (including labels) are noted. Any stand that appears damaged in any way, operates abnormally or is missing parts, should be removed from service immediately and the manufacturer notified. If you suspect that the stand was subjected to a shock load (a load dropped suddenly, unexpectedly upon it), immediately discontinue use until stand has been checked by a Factory Authorized Service Center (contact distributor or manufacturer for list of authorized service centers). It is recommended that an annual inspection be done by qualified personnel. Labels and owner's manuals are available from manufacturer.

PRODUCT DESCRIPTION

ATD Tools Underhoist Tripod Stand is designed to help prevent the tipping or rocking of a vehicle while the vehicle is on an automotive lift. It is to be used in pairs to **stabilize** a vehicle during service. It is **not** intended to support the lifted load, only to stabilize the load as work is being performed under a **properly secured lift**. The rated capacity of this device is intended to be used as a reference of the working load that this stand is capable of sustaining. The working load is **NOT** increased if used in pairs. The working load of a pair of stands **should not** be considered to be more than the rated capacity of a single stand. The rated capacity of this stand is **4000 lbs.**



NEVER use high reach supplementary stand to support a vehicle! Use a pair to prevent vehicle tipping or rocking while vehicle is on an automotive lift.

SPECIFICATIONS

Model	Capacity	Base Size	Min. Height	Max. Height	Saddle Size	Net Weight
ATD-7440	2 Ton	24" x 22-1/2"	69"	78-1/2"	5-1/4" x 1-1/2"	54 lbs.

BEFORE USE

1. Inspect stand before each use. Do not use if bent, broken or cracked components are noted. Ensure that all parts move freely.
2. Verify that the product and the application are compatible.
3. **Before** using this product, **read the owner's manual and familiarize yourself thoroughly** with the product and hazards associated with its improper use.
4. Always check the vehicle owner's or service manual for location of proper lift and support points. This device is designed to **stabilize, NOT SUPPORT** a vehicle while on an automotive lift. Special skills and knowledge pertaining to working on and around an automotive lift may be required before attempting to position/use this device.



WARNING

- Study, understand, and follow all printed materials provided with/on this device before use.
- Do not exceed rated capacity.
- Use only on hard, level surface.
- Center load on saddle.
- **Do not** use the stand to support a vehicle.
- Use stands in pairs **under a properly secured automotive lift** to stabilize the vehicle before starting repairs.
- Only attachments and/or adapters supplied by the manufacturer should be used.
- No alteration should be made to this device
- Failure to heed these markings may result in personal injury and/or property damage.

ASSEMBLY

Before beginning assembly of product, make sure all parts are present. Compare parts with package contents listed in Figure 1 & Parts List on page 4.

Estimated Assembly Time: 15 minutes

Tools Required for Assembly: 8mm Wrench, Hammer and punch (Not included).

1. Attach lower plate (12) and upper plate (11) to tripod legs (15) using bolts & nuts (9 & 10) provided. Finger tighten only. Make sure both plates are placed above the screw hole.
2. Attach lower and upper links (14 & 16) using bolts and nuts (9&10) provided. Do not use any tools to tighten.
3. Insert threaded column (13) into column tube (7).
4. Insert bearing (6) and height adjustment handle (4) into threaded column (13).
5. Attach saddle (2) on top of the threaded column (13) and use a hammer to punch the pin (3) into the threaded column.
6. Insert the assembly of steps 4 and 5 through the upper plate (11).
7. Insert the lock pin (8) to the bottom of the tube (7).
8. Tighten securely all the bolts and nuts.

OPERATION

 **Use only on areas of the vehicle as specified by the vehicle manufacturer. Use ONLY on vehicles whose contact points are compatible with the saddles of these stands. Incompatibility may result in structural damage to the vehicle and/or stand. Structural damage to either may result in sudden and unexpected loss of load height!**

To Raise Saddle

1. Refer to the vehicle service manual or vehicle manufacturer for location of proper lift and support points. This device is designed to **stabilize, NOT SUPPORT** a vehicle while on an automotive lift.

 **Special skills and knowledge pertaining to working on, under, and around a vehicle on an automotive lift is required before attempting to position/use this device.**

2. Locate and turn the height adjustment handle clockwise.

To Lower Saddle

 **Be sure all tools and personnel are clear before lowering load.**

Slowly turn height adjustment handle counterclockwise. Ensure vehicle is balanced and secure on the vehicle lift before removing this device.

MAINTENANCE

Periodically inspect each stand. Ensure all parts move freely. Apply grease to fitting as needed. If rust appears, sand affected area and cover with suitable utility paint.

REPLACEMENT PARTS

(Refer to Figure 1 and Parts List on Page 4)

Not all components of the stand are replacement items, but are illustrated as a convenient reference of location and position in the assembly sequence. When ordering parts, give model number, part number and description below.

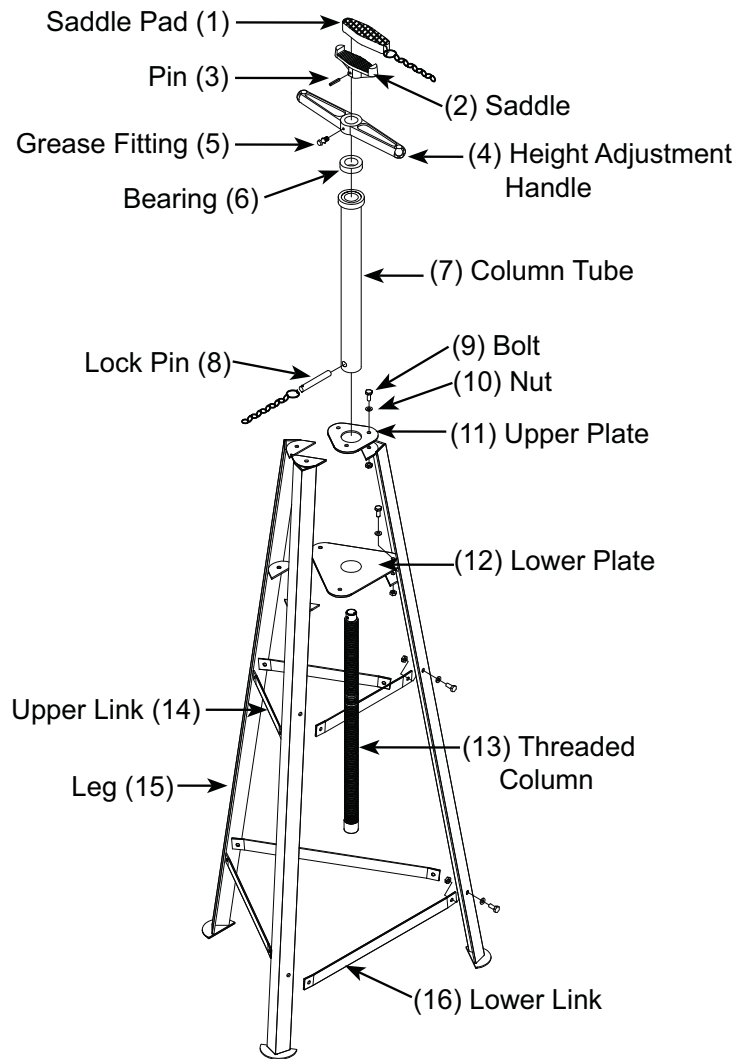

Figure 1 - Model ATD-7440 components

Item	Part No.	Description	Qty
1	T455-00002-000	Saddle Pad	1
2	T455-00003-000	Saddle	1
3	*	Pin, D6x40mm	1
4	T455-00001-000	Height Adjustment Handle	1
5	*	Grease Fitting	1
6	*	Bearing	1
7	T457-02000-000	Column Tube	1
8	T457-04000-000	Lock Pin	1
9	*	HCS M8X15	18
10	*	Nut, Hex M8	18
11	T457-00003-000	Upper Plate	1
12	T457-05000-000	Lower Plate	1
13	T457-03000-000	Threaded Column	1
14	T457-00002-000	Link, Upper	3
15	T457-01000-000	Leg	3
16	T457-00001-000	Link, Lower	3
(*)	T457-06000-000	Hardware Kit	-