

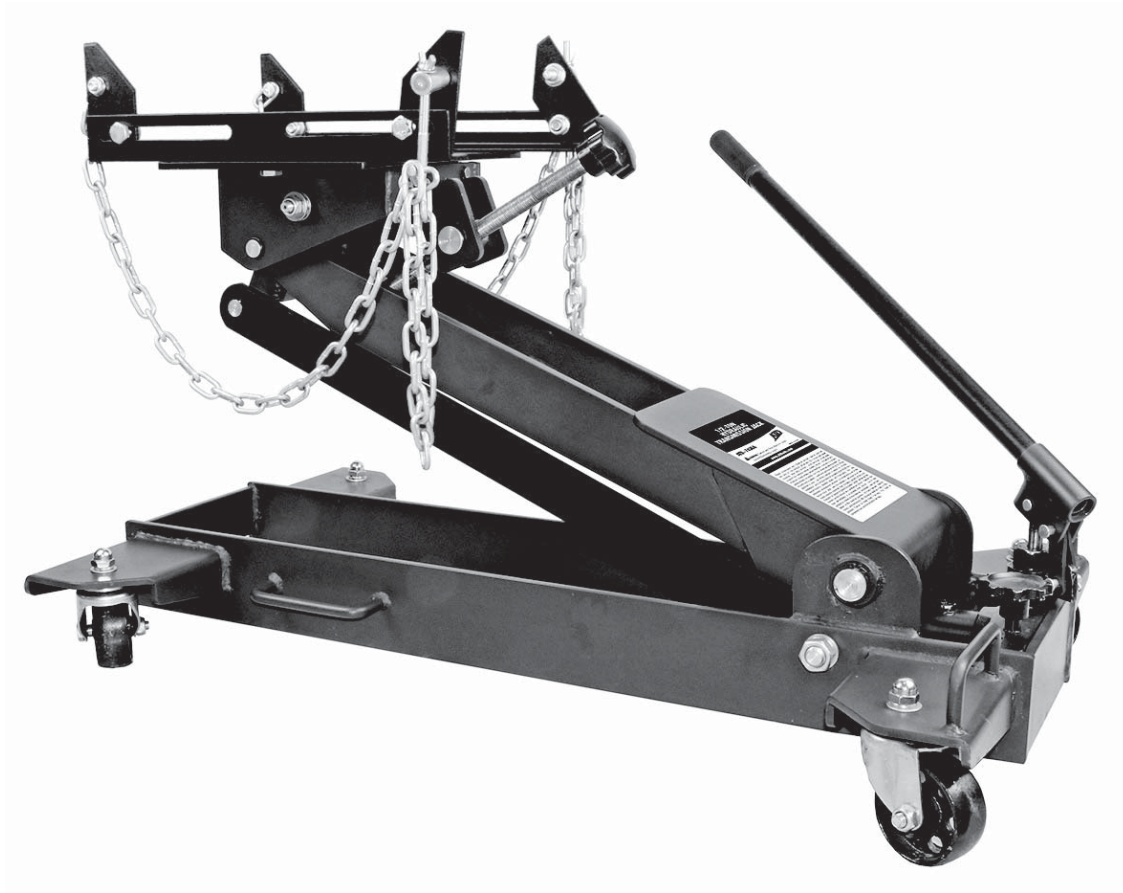

ATD-7435A

1/2-Ton Heavy-Duty Hydraulic Floor Style Transmission Jack Owner's Manual



Features:

- The adjustable head can be tilted forward, backward and side-to-side for optimum alignment of transmission during service
- Bypass valve protects the hydraulic system from internal damage
- Safety load restraining chains secure transmission during raising and lowering
- (4) swivel casters allow easy movement and positioning of transmission jack
- Rugged steel wheels and full swivel ball bearing casters for maximum durability
- User-friendly 360° rotating pump handle allows maximum multi-directional operation
- Welded power unit for long life
- Meets or exceeds ASME/PASE 2019 standards

Specifications:

- Capacity (Ton): 1,100 lbs.
- Minimum Height: 6-15/16"
- Maximum Height: 28-5/16"
- Handle Length: 17-15/16"
- Saddle Base: 13-3/8" x 7-7/8"
- Expanded Saddle Area: 13-9/16" x 15"
- Size: 33-5/8" L x 19-3/4" W x 7-1/2" H
- Shipping Weight: 140.80 lbs.

SAVE THESE INSTRUCTIONS

For your safety, read, understand, and follow the information provided with and on this jack. The owner and operator of this equipment should have an understanding of this jack and safe operating procedures before attempting to use. The owner and operator should be aware that use and repair of this product may require special skills and knowledge. Instructions and safety information should be conveyed in the operator's native language before use of this jack is authorized. Make certain that the operator thoroughly understands the inherent dangers associated with the use and misuse of the product. If any doubt exists as to the safe and proper use of this jack, remove from service immediately.

Inspect before each use. Do not use if broken, bent, cracked or damaged parts are noted. Any jack that appears damaged in any way, or operates abnormally should be removed from service immediately. If the jack has been or suspected to have been subjected to a shock load (a load dropped suddenly, unexpectedly upon it), immediately discontinue use until jack has been checked by a factory authorized service center. It is recommended that an annual inspection be done by qualified personnel. Labels and operator's manuals are available from manufacturer.

PRODUCT DESCRIPTION:

ATDTools Hydraulic Transmission Jacks are designed to be used as an aid in the removal and installation of automotive and light truck transmissions, transfer cases and transaxles. They are intended for use under an overhead lift or in a garage pit. This jack meets or exceeds ASME/PASE 2019 standards

CAUTION! Read carefully before unpacking product

SAFETY INSTRUCTIONS:

BEFORE USE

1. Inspect jack before each use. Do not use if bent, broken or cracked components are noted. Ensure that casters move freely. Check for and tighten any loose assemblies.
2. Verify that the product and the application are compatible.
3. Remove oil filler plug/screw prior to initial use to confirm oil level is at or just above the inner cylinder as seen from the reservoir, fill as needed and reinstall oil filler plug/screw.

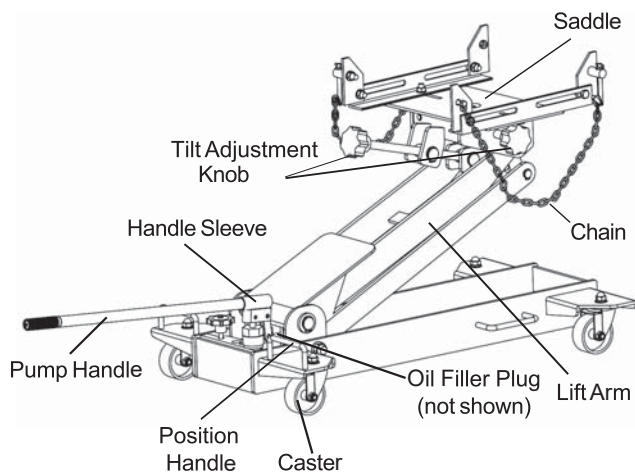

Figure 1 - Model ATD-7435A components

⚠ WARNING

- Study, understand, and follow all printed materials provided with/on this product before use.
- Do not exceed rated capacity.
- Use only on hard, level surfaces capable of supporting rated capacity loads.
- Use of this jack is limited to the removal, installation and transportation of transmissions, transfer cases and transaxles. Do not use a transmission jack to tilt or support a vehicle.
- Ensure the center gravity of load is centered on the saddle.
- For your safety, do not exceed 10° tilt angle of the saddle assembly in all directions.
- Adequately support the vehicle before starting repairs.
- Use only chains and slings provided.
- If loaded jack must be moved, make sure that the load is secured, stable and in lowest position.
- This is a lifting and lowering device only.
- Transfer load immediately to appropriate support device for service or repair.
- Shock loads may cause the sudden loss of load and/ or cause the jack to tip or flip over violently, bend or break.
- No alterations shall be made on this product
- Failure to heed these markings may result in personal injury and/or property damage.

ASSEMBLY:

Assemble the (4) L-shaped extension arms onto the corners of the saddle. Line up the elongated hole of the extension arm with the hole at the saddle, insert bolt and washer and then hand tighten the nut at the bottom. Repeat the assembly process for all 4 pieces of extension arm.

OPERATION:

Lifting

- Ensure the vehicle is at the desired work height and properly and securely supported
- Turn the release valve knob clockwise to the closed position. Do not over tighten.
- Position the jack under the specified lift point.
- Begin lifting by pumping the handle up and down until saddle contacting the transmission or load.
- Adjust four extension arms by loosening the bolts in and out. To position the transmission or load on the saddle, tighten the four bolts to secure the extension arms to the saddle.
- If necessary, adjust the fore & aft and side-to-side saddle tilt adjustment knobs to properly position the transmission or load on the saddle.
- Ensure the center of gravity of transmission or load is centered on the saddle and stable.
- Immediately after lifting, secure the transmission or load with provided chain.
- Remove the transmission or load from the engine according to instruction in the vehicle owner's manual.



Lowering

- Ensure the transmission or load has been disconnected from the engine.
- Do not get under or let anyone get under the vehicle while lowering.
- Turn the release valve slowly counterclockwise to lower the transmission or load to the lowest position.
- Immediately transfer the transmission or load to an appropriate work station

MAINTENANCE:

Check and Refill Oil

- With the jack in the fully lowered, level position, remove oil filler plug.
- Proper oil level should be just covering inner cylinder as seen from the oil filler plug hole.
- Do not overfill. Always fill with new, clean hydraulic jack oil. We recommend Mobil DTE 13M or equivalent.
- Reinstall oil filler plug.

Lubrication and Cleaning

- Periodically clean and lubricate all moving parts and pivot points.

Air Venting Procedures

- With the jack in the fully lowered position, release valve open, remove oil filler plug.
- Pump the handle rapidly several times. Reinstall oil filler plug.
- Turn the release valve knob clockwise to the closed position.
- Pump the handle until the lift arm reaches maximum height and continue to pump several times to remove trapped air in the system.
- Turn the release valve knob counterclockwise in one full turn and lower lift arm to the lowest position. Use force on saddle if necessary.
- Carefully and slowly loosen oil filler plug to release pressurized air.
- Repeat above steps until trapped air is completely vented.

Damaged Equipment

Any jack that appears to be damaged in any way, is found to be worn, or operates abnormally **SHOULD BE REMOVED FROM SERVICE UNTIL REPAIRED**. It is recommended that necessary repairs be made by a manufacturer's or supplier's authorized repair facility if repairs are permitted by the manufacturer or supplier.

MAINTENANCE CONTINUED:

Alterations

Because of potential hazards associated with this type of equipment, no alterations should be made to the product.

Attachments and Adapters

Only attachments and/or adapters supplied by the manufacturer should be used.

Storage

This Jack should be stored in a dry location on a level surface.

TROUBLESHOOTING

Symptom	Possible Causes	Solution
Jack will not lift the load.	<ol style="list-style-type: none"> 1. Release valve not tightly closed. 2. Low oil level. 3. Defective or worn internal parts. 4. Load exceeds maximum allowance. 	<ol style="list-style-type: none"> 1. Tighten release valve knob. 2. Check and add oil. Follow "Check and Refill Oil" instructions on Pg.3. 3. Discontinue use and contact a local repair center. 4. Use a higher capacity jack.
Jack will not hold the load.	<ol style="list-style-type: none"> 1. Release valve not tightly closed. 2. Power unit malfunction. 	<ol style="list-style-type: none"> 1. Tighten release valve knob. 2. Discontinue use and contact a local repair center.
Jack will not descend to minimum height, or will not remain in lowered position.	<ol style="list-style-type: none"> 1. Air trapped in system. 2. Reservoir oil overfilled. 	<ol style="list-style-type: none"> 1. Vent air out of system. Follow "Air Venting Procedures" on Pg.3. 2. Check and ensure proper oil level. Follow "Check and Refill Oil" instruction on Pg.3.
Jack will not lift to max height.	Low oil level.	<p>Check and ensure proper oil level.</p> <p>Follow "Check and Refill Oil" instructions on Pg.3.</p>
Jack will not function properly after tried solution.	Internal malfunction or structural damage.	Stop usage and contact an authorized repair center.

Inspection

- A visual inspection should be made before each use of the device by checking for abnormal conditions, such as cracked welds, leaks, and damaged, loose, or missing parts.
- Other inspections should be made per product operating instructions.
- This device should be inspected immediately if the device is believed to have been subjected to an abnormal load or shock. It is recommended that this inspection be made by a manufacturer's or supplier's authorized repair facility.
- Owners and/or operators should be aware that repair of this equipment may require specialized knowledge and facilities. It is recommended that an annual inspection of the product be made by a manufacturer's or supplier's authorized repair facility and that any defective parts, decals, or safety labels or signs be replaced with manufacturer's or supplier's specified parts.

Replacement Parts for model ATD-7435A:

REPLACEMENT PARTS

Available Parts: Please refer to the Parts drawing when ordering parts. Not all components of this kit are replacement items, but are illustrated as a convenient reference of location and position in the assembly sequence. When ordering parts, give model number, serial number and description. Call your distributor for current pricing.

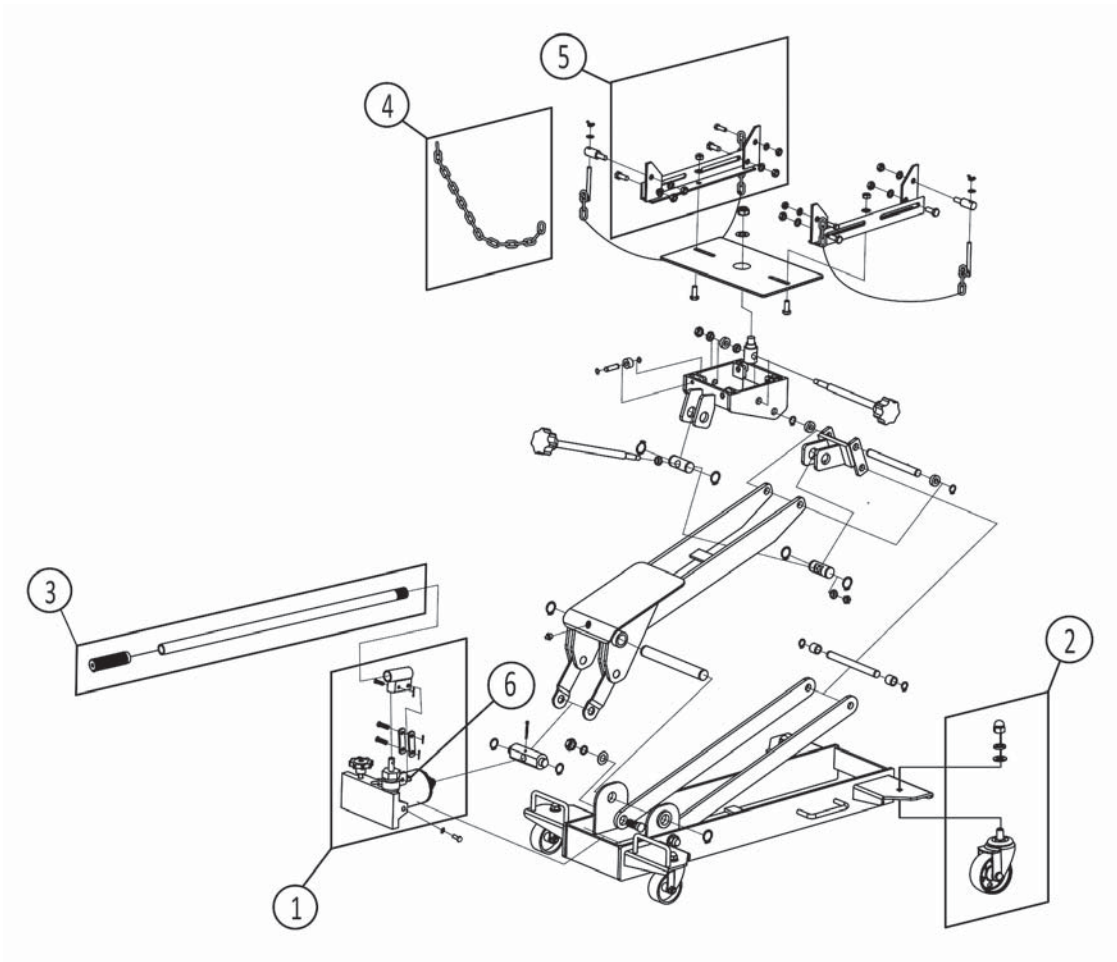

Figure 2 - Replacement Parts Illustration for model ATD-7435A

Item	Part Number	Description	Q'ty
1	7435A-1	Power Unit Assembly	1
2	7435A-2	Rear Caster Assembly	4
3	7435A-3	Handle Assembly	1
4	7435A-4	Chain	2
5	7435A-5	Saddle Bracket Assembly	2
6	7435A-6	Oil Filler Screw w/ Seal	1
N/A	7435A-L	Label	1

* Items not identified by part number are not available for replacement.