



Hydraulic Air/Manual Bottle Jacks

Operating Instructions & Parts Manual

Model Number

ATD-7421

ATD-7422

Capacity

12 Ton

20 Ton

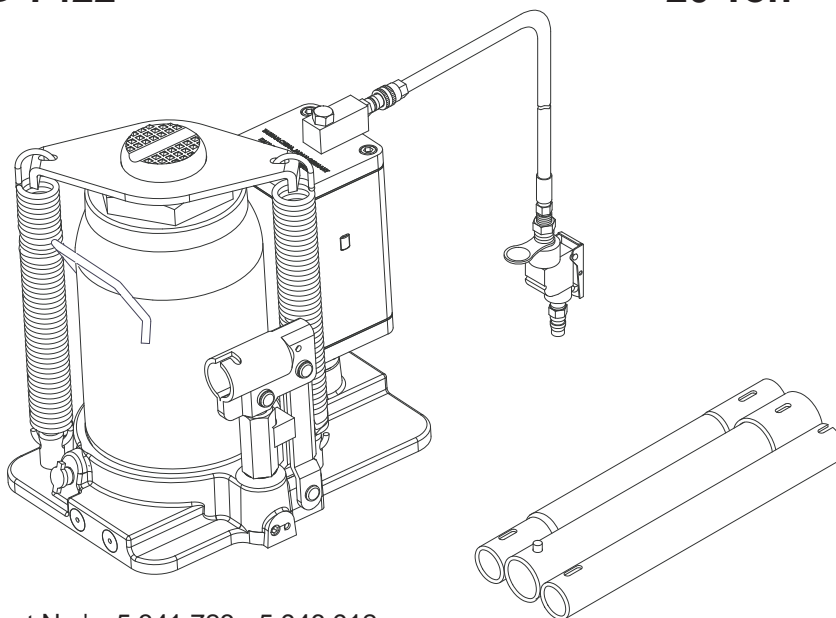

U.S. Patent No.'s. 5,341,723 - 5,946,912



This is the safety alert symbol. It is used to alert you to potential personal injury hazards. Obey all safety messages that follow this symbol to avoid possible injury or death.

! WARNING	
	<i>To avoid crushing and related injuries: NEVER work on, under or around a load supported only by a hydraulic jack. ALWAYS use a pair of adequately rated jack stands.</i>

Read this manual and follow all the Safety Rules and Operating Instructions before using this product.

! WARNING !	
WARNING: This product may contain chemicals, including lead, known to the State of California to cause cancer, birth defects or other reproductive harm. <i>Wash hands after handling.</i>	

SAFETY AND GENERAL INFORMATION

Save these instructions. For your safety, read, understand, and follow the information provided with and on this device before using. The owner and/or operator shall have an understanding of the device, its operating characteristics and safety operating instructions before operating the equipment. The owner and/or operator shall be aware that use and repair of this product may require special skills and knowledge. Instructions and safety information shall be read to and discussed with the operator in the operator's native language, making sure that the operator comprehends their contents, before use of this equipment is authorized. If any doubt exists as to the safe and proper use of this device, remove from service immediately.

Inspect before each use. Do not use if abnormal conditions such as cracked welds, damaged, loose or missing parts are noted. Any equipment that appears damaged in any way, is found to be worn, or operates abnormally shall be removed from service until repaired. If the equipment has been or is suspected to have been subjected to an abnormal load or shock, immediately discontinue use until inspected by a factory authorized repair facility (contact distributor or manufacturer for list of authorized repair facilities). It is recommended that an annual inspection be made by an authorized repair facility. Labels and Operator's Manuals are available from the manufacturer.

PRODUCT DESCRIPTION

ATD Tools Air Hydraulic Bottle Jacks are designed to lift rated capacity loads consisting of one end of a vehicle. Immediately after lifting, the load must be supported by a pair of appropriately rated jack stands. Ensure that air source can dedicate 7.8 CFM @ 110-175 psi to each jack operated. A minimum of 150 psi air pressure is required to raise rated capacity load.

⚠ WARNING: *Never use a hydraulic jack as a stand alone support device. After lifting, immediately support the vehicle with appropriately rated jack stands. Never place any portion of your body under the vehicle when lifting or lowering.*

PREPARATION

Before Use

1. Before using this product, read the operator's manual completely and familiarize yourself thoroughly with the product, its components and recognize the hazards associated with its use.
2. Verify that the product and application are compatible.
3. Assemble handle, ensure spring clips align with slots.
4. To familiarize yourself with basic operation, use the notched end of provided handle to engage and turn the release valve:
 - a. *Clockwise* until firm resistance is felt to further turning. This is the '**CLOSED**' release valve position used to raise the ram plunger.
 - b. *Counter-clockwise*, but no more than 1 turn from the closed position. This is the '**OPEN**' release valve position used to lower the ram plunger.
5. With saddle fully lowered, and release valve closed, pump the operating handle. If ram responds immediately, jack is ready for use. If jack does not respond, follow **Bleeding/Venting Trapped Air** procedure below.
6. Pour a teaspoon of good quality, air tool lubricant into the air supply inlet of the lift control valve. Connect to air supply and squeeze lift control valve for 3 seconds to evenly distribute lubricant.

NOTICE: *This product is equipped with the popular 1/4" NPT air coupler. When installing a different air coupler of your choice, ensure that thread tape or compound is used when servicing connections. To ensure dependable, trouble free operation an in-line air dryer and oiler is recommended.*

7. Check that the pump operates smoothly and that the extension screw adjusts up/down easily before putting into service. Replace worn or damaged parts and assemblies with factory authorized replacement parts only.

Bleeding/Venting Trapped Air

With the release valve in the OPEN position (4b above) and with ram plunger fully lowered, locate and remove the air vent screw/filler plug. Insert the handle into the handle sleeve, then pump 6 to 8 full strokes. This will help release any pressurized air which may be trapped within the reservoir. Oil level should be even with the bottom of the oil filler hole. Reinstall the air vent screw/filler plug.

⚠ WARNING

- Study, understand, and follow all instructions before operating this device.
- Do not exceed rated capacity.
- Use only on hard, level surface.
- This is a lifting device only. Immediately after lifting, support the load with appropriate means.
- Lift only on areas of the vehicle as specified by the vehicle manufacturer.
- No alterations shall be made to this product.
- Only attachments and/or adapters supplied by the manufacturer shall be used.
- Failure to heed these markings may result in personal injury and/or property damage.

⚠ WARNING

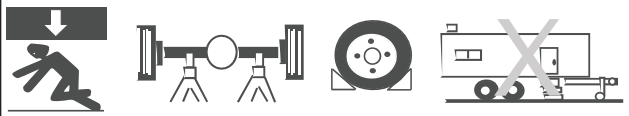

To avoid crushing and related injuries:

- Never work on, under or around a load supported only by hydraulic jack.
- Chock unlifted tires in both directions.
- Do not use this device to lift, level, lower, support nor move a house, mobile home, travel trailer, camper or any building structure.
- Be alert and sober when using this product. Do not operate under the influence of drugs or alcohol.

SPECIFICATIONS

Model	Capacity	Base Size (L x W)	Minimum Height	Maximum Height	Hydraulic Lifting	Extension Screw	Air Supply	Weight
ATD-7421	12 Ton	8-1/8" x 5-7/8"	9-5/8"	18-7/8"	3-1/8"	6"	110-175 psi @ 7.8 CFM	27 lbs.
ATD-7422	20 Ton	9" x 6-3/4"						37 lbs.

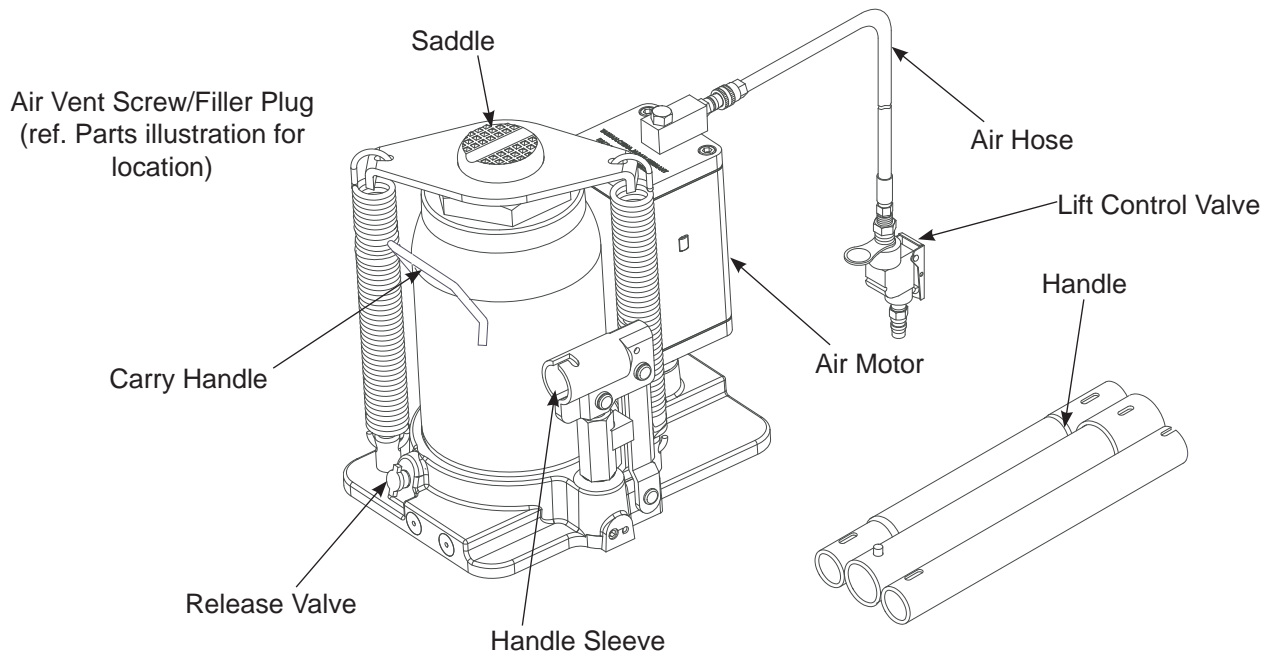

Figure 1 - ATD-7421 & ATD-7422 nomenclature

OPERATION

Raising the Ram Plunger

1. Assemble handle, ensure that spring clips align with slots.
2. Place vehicle in park, with emergency brake on and wheels securely chocked to prevent inadvertent vehicle movement.
3. Close release valve by turning handle clockwise until firm resistance is felt.

NOTICE: *Always use the provided pump handle. The handle furnished with this jack will safely engage the release valve and operate the Handle Sleeve. If handle is worn, operates abnormally, or will not positively engage the release valve, discontinue use of the jack until a factory replacement handle can be acquired.*

4. Verify lift point, center jack saddle under lift point.

⚠ WARNING: *Never wire, clamp or otherwise enable the lift control valve to function by other than operator's hand. Do not attempt operating pump by air and by handle simultaneously.*

5. Squeeze the lift control valve or insert handle into handle sleeve and pump to contact lift point. To lift, continue pumping until load reaches desired height.
6. Immediately transfer the load to a pair of appropriately rated jack stands.

NOTICE: *Do not use extensions on air hose or operating handle.*

Lowering

⚠ WARNING: *Clear all tools and personnel before lowering load. Open release valve slowly. The further handle is turned counter-clockwise, the faster the load will descend. Maintain control of the load at all times.*

1. Raise load high enough to clear the jack stands, then carefully remove jack stands.
2. Slowly turn the handle counter-clockwise, but no more than 1/2 turn. *If the load fails to lower:*
 - a. Use another jack to raise the vehicle high enough to reinstall jack stands.
 - b. Remove the affected jack and then the stands.
 - c. Lower the load using the functioning jack.
3. After removing jack from under the load, push ram and handle sleeve down to reduce exposure to rust and contamination.

MAINTENANCE

NOTICE: *Use premium quality hydraulic jack oil. Avoid mixing different types of fluid and NEVER use brake fluid, turbine oil, transmission fluid, motor oil or glycerin. Improper fluid can cause premature failure of the jack and the potential for sudden and immediate loss of load.*

Adding oil

1. With ram plunger fully lowered and pump piston fully depressed, set jack in its upright, level position. Remove air vent screw/filler plug.
2. Fill with oil until just below the rim of the air vent screw/filler plug hole. Reinstall the air vent screw/filler plug.

Changing oil

For best performance and longest life, completely replace the fluid supply at least once per year.

1. With ram plunger fully lowered and pump piston fully depressed, remove the air vent screw/filler plug.
2. Lay the jack on its side and drain the fluid into a suitable container.

NOTICE: *Dispose of hydraulic oil in accordance with local environmental regulations.*

3. Fill with oil until just below the rim of the air vent screw/filler plug hole. Reinstall the air vent screw/filler plug.

Lubrication

1. A periodic coating of light lubricating oil to pivot points, axles and hinges will help to prevent rust and assure that pump assemblies move freely.
2. When used on a daily basis, air pump should be internally lubricated before each use. Use premium quality air tool lubricant. If no inline oiler is used, pour a teaspoon of air tool oil into the inlet of the air control valve. Simply operate the jack using the air feature in order to fully distribute the oil.

Cleaning

Periodically check the pump piston and ram plunger for signs of rust or corrosion. Clean as needed and wipe with an oily cloth.

NOTICE: *Do not use sandpaper or abrasive material on ram and pump piston surfaces.*

Storage

When not in use, store the jack with pump piston and ram plunger fully retracted and air supply disconnected.

TROUBLESHOOTING

Symptom	Possible Causes	Corrective Action
Jack will not lift load	<ul style="list-style-type: none"> • Release valve not tightly closed • Overload condition • Air pressure inadequate 	<ul style="list-style-type: none"> • Ensure release valve tightly closed • Remedy overload condition • Ensure adequate air pressure
Jack will lift, but not maintain pressure	<ul style="list-style-type: none"> • Release valve not tightly closed • Hydraulic unit malfunction 	<ul style="list-style-type: none"> • Ensure release valve tightly closed
Jack will not lower after unloading	<ul style="list-style-type: none"> • Reservoir overfilled 	<ul style="list-style-type: none"> • Ensure load is removed, then drain fluid to proper level
Poor lift performance	<ul style="list-style-type: none"> • Fluid level low • Air trapped in system 	<ul style="list-style-type: none"> • Ensure proper fluid level • With ram fully retracted, remove oil filler plug/screw to let pressurized air escape, then reinstall oil filler plug/screw
Will not lift to full extension	<ul style="list-style-type: none"> • Fluid level low 	<ul style="list-style-type: none"> • Ensure proper fluid level

REPLACEMENT PARTS

Not all components of the jack are replacement items, but are illustrated as a convenient reference of location and position in the assembly sequence. When ordering parts, give model number, serial number and parts description. Call your distributor for current pricing.

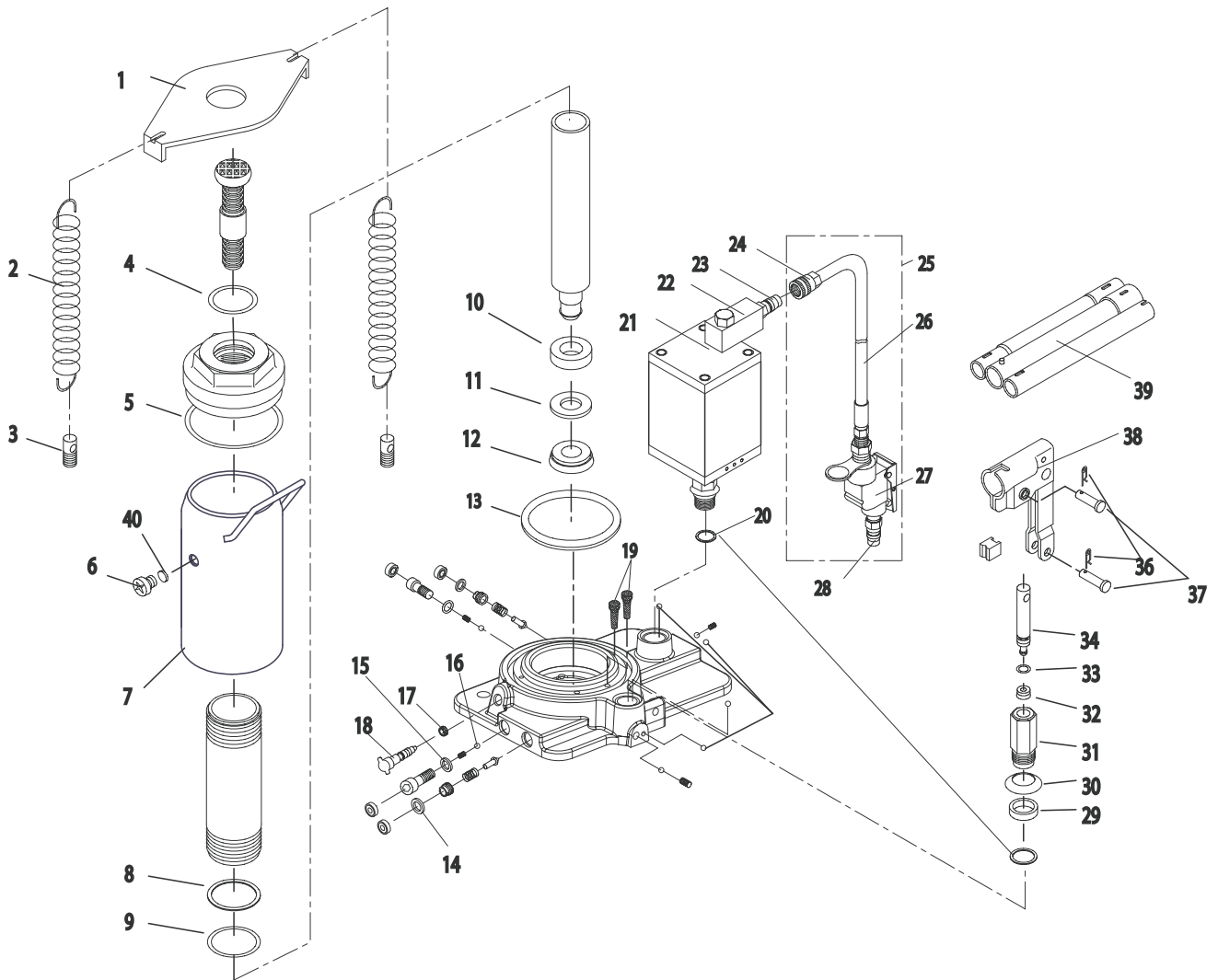

Figure 2 - Replacement Parts Illustration

Replacement Parts List for models ATD-7421 & ATD-7422

Item	Part No. for ATD-7421	Part No. for ATD-7422	Description	Qty
1	A240-10002-000	A200-10003-000	Cover	1
2	A200-10002-000	A200-10002-000	Extension Spring	2
3	A200-10004-000	A200-10004-000	Screw	2
4	*	*	O-ring	1
5	*	*	Gasket	1
6	5905-00100-200*	G62S-03301-000*	Air Vent Screw/Filler Plug	1
7	N/A	N/A	Reservoir Assy	1
8	*	*	Back-up Ring	1
9	*	*	O-ring	1
10	*	*	Ram Bearing	1
11	*	*	Back-up Ring	1
12	*	*	U-cup	1
13	*	*	Seal	1
14	*	*	O-ring	2
15	*	*	Special Washer	2
16	*	*	Steel Ball	6
17	*	*	Seal	1
18	BT10-24001-000	BT10-24001-000	Release Valve	1
19	B020-10003-000	B120-10003-000	Filter	2
20	*	*	Gasket	2
21	G831-03200-000	G831-03200-000	Air Motor Assy	1
22	A240-01000-000	A240-01000-000	Air Inlet Swivel	1
23	A240-02400-000	A240-02400-000	Quick-coupler, Male	1
24	A240-02300-000	A240-02300-000	Quick-coupler, Female	1
25	A240-02000-000	A240-02000-000	Hose Assy	1
26	A240-02100-000	A240-02100-000	Hose Assy	1
27	A240-02200-000	A240-02200-000	Air Inlet Control Valve	1
28	A240-02400-000	A240-02400-000	Quick-coupler, Male	1
29	*	*	Packing	1
30	B020-15002-000	B020-15002-000	Washer	1
31	B080-15001-000	B080-15001-000	Pump Cylinder	1
32	*	*	Oil Seal Assy	1
33	*	*	O-ring	1
34	A120-15101-000	A120-15101-000	Pump Piston	1
35	N/A	N/A	Rubber Pad	1
36	5405-02018-000	5405-02018-000	Snap Pin	2
37	5405-07027-000	5405-07027-000	Pin	2
38	B10N-14000-000	B10N-14000-000	Handle Sleeve Assy	1
39	B10N-21000-000	B10N-21000-000	Handle Assy	1
40	N/A	*	O-ring	1
*	A2406S-053	A2006S-054	Repair Kit	