



Hydraulic Long Chassis Service Jacks

Operating Instructions & Parts Manual

Model Number
ATD-7390
ATD-7391

Capacity
5 Ton
10 Ton

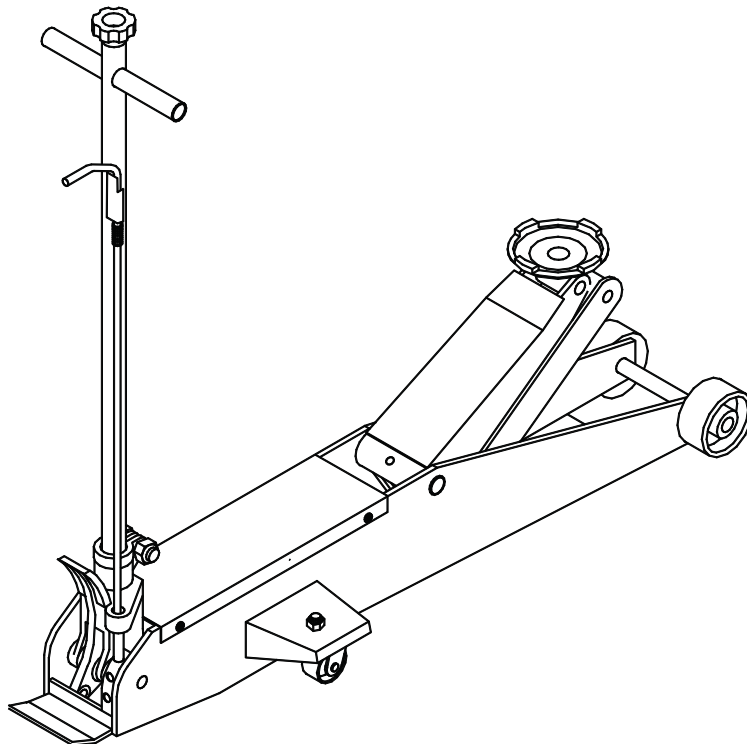

⚠ WARNING ⚠

WARNING: This product may contain chemicals, including lead, known to the State of California to cause cancer, birth defects or other reproductive harm. *Wash hands after handling.*

Made in China to ATD Tools, Inc. Specifications

Save these instructions. For your safety, read, understand, and follow the information provided with and on this jack. The owner and operator of this equipment shall have an understanding of this jack and safe operating procedures before attempting to use. The owner and operator shall be aware that use and repair of this product may require special skills and knowledge. Instructions and safety information shall be conveyed in the operator's native language before use of this jack is authorized. If any doubt exists as to the safe and proper use of this jack, remove from service immediately. **Inspect before each use.** Do not use if broken, bent, cracked, or damaged parts (including labels) are noted. Any jack that appears damaged in any way, operates abnormally or is missing parts, shall be removed from service immediately. If the jack has been or suspected to have been subjected to a shock load (a load dropped suddenly, unexpectedly upon it), immediately discontinue use until jack has been checked by a factory authorized service center. It is recommended that an annual inspection be done by qualified personnel. Labels and Operator's Manuals are available from manufacturer (see Replacement Parts, pages 5 thru 7).

PRODUCT DESCRIPTION

ATD Tools Long Chassis Hydraulic Service Jacks are designed to lift, **not** sustain, rated capacity loads. They are designed to be used in conjunction with jack stands. **Intended use:** To lift one axle of a vehicle for the purpose of service and/or repair of vehicle components. After lifting, loads must be immediately supported by appropriately rated jack stands. Check with vehicle owner's manual for proper lift points.

DO NOT USE TO DOLLY OR MOVE VEHICLE. DO NOT USE FOR ANY PURPOSE OTHER THAN THOSE USES OUTLINED ABOVE!

SPECIFICATIONS

Model	Capacity	Jack Size (L x W x H)	Min. Height	Max. Height	Handle Length	Saddle Diameter	Ram Extend	Weight
ATD-7390	5 Ton	57-3/4" x 17" x 7-5/8"	7"	27"	42-1/8"	6-1/2"	5"	233 lbs.
ATD-7391	10 Ton	54-3/4" x 20" x 12-3/4"				7-3/8"	6-1/2"	427 lbs.

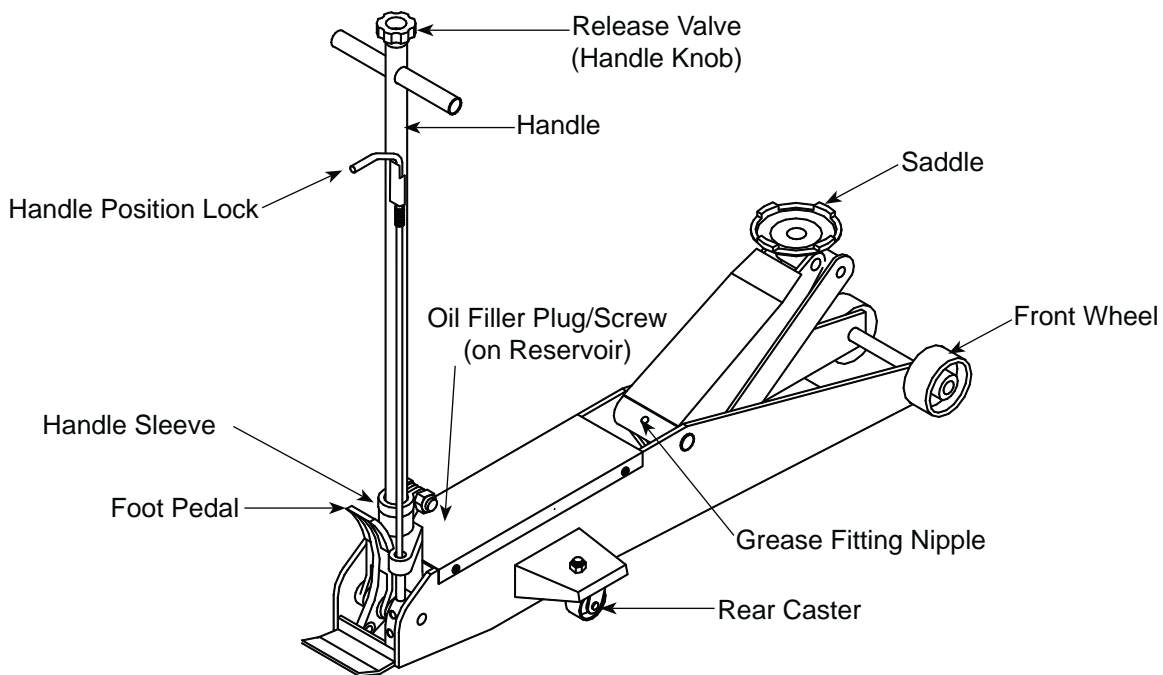

Figure 1 - Typical Long Chassis Jack nomenclature (ATD-7390 shown)

ASSEMBLY

Always secure the handle into the handle sleeve by means of the bolt lock washer and nut provided. Tighten securely to prevent accidental removal of handle while in use. Familiarize yourself with the illustrations in the operator's manual. Know your jack and how it operates before attempting to use.

BEFORE USE

1. Verify that the product and the application are compatible.
2. Before using this product, read the operator's manual completely and familiarize yourself thoroughly with the product, its components and recognize the potential hazards associated with its use.
3. Open the release valve by turning the handle counter-clockwise (no more than 1/2 full turn).
4. With saddle fully lowered, locate and remove the oil filler plug/screw. Pump handle 6 to 8 full strokes. Ensure the oil level is within ~ 3/16" from the inner cylinder as viewed from the oil filler hole. Reinstall the oil filler plug/screw. Close release valve by turning the handle clockwise until firm resistance is felt.
5. Check to ensure that jack rolls freely, that the pump and release valve operate smoothly. Raise and lower the unloaded saddle throughout the advertised lift range before putting into service.
6. Replace worn or damaged parts and assemblies with factory authorized replacement parts only. (See Replacement Parts Section). Lubricate as instructed in Maintenance Section.

WARNING

- Study, understand, and follow all printed materials provided with/on this product before use.
- Do not exceed rated capacity.
- This is a lifting device only.
- Use only on hard, level surfaces capable of supporting rated capacity loads.
- After lifting, immediately transfer the load to appropriately rated vehicle stands.
- Never work on, under, or around a load supported by this device only.
- Do not move or dolly loads with this device.
- No alterations shall be made on this product.
- Failure to heed these markings may result in personal injury and/or property damage.

OPERATION

Lifting

CAUTION

Lift only on areas of the vehicle as specified by the vehicle manufacturer.
Do not use adapters or accessories that are not provided initially.
The resulting of overload may cause hydraulic system failure.

1. Place vehicle in park, with emergency brake on and wheels securely chocked to prevent inadvertent vehicle movement.
2. Locate and close release valve by turning handle clockwise, firmly. Center jack saddle under lift point.
3. Verify lift point, then use handle pump to contact lift point. To lift, pump handle until load reaches desired height.
4. Transfer the load immediately to appropriately rated jack stands.

WARNING



To avoid crushing and related injuries:
NEVER work on, under or around a load supported only by jack. ALWAYS use adequately rated jack stands.

Lowering

WARNING

Be sure all tools and personnel are clear before lowering load.

1. Raise load high enough to clear the jack stands, then carefully remove jack stands (**always** used in pairs).
2. Slowly turn the handle counterclockwise, but no more than 1/2 turn. If the load fails to lower:
 - a. Use another jack to raise the vehicle high enough to reinstall jack stands.
 - b. Remove the affected jack and then the stands.
 - c. Using the other jack, lower the load by turning the operating handle counter-clockwise, but no more than 1/2 turn.
3. After removing jack from under the load, push saddle down to reduce ram exposure to rust and contamination.

MAINTENANCE

Important: Use only good grade hydraulic jack oil. Avoid mixing different types of fluid and NEVER use brake fluid, turbine oil, transmission fluid, motor oil or glycerin. Improper fluid can cause premature failure of the jack and the potential for sudden and immediate loss of load. We recommend Mobil DTE 13M or equivalent.

Adding oil

1. With saddle fully lowered set jack in its upright, level position. Locate and remove oil filler plug/screw.
2. Fill with oil until ~3/16" above the inner cylinder as seen from the oil filler hole. Reinstall the oil filler plug/screw.

Changing oil

For best performance and longest life, replace the complete fluid supply at least once per year.

1. With saddle fully lowered, remove the oil filler plug/screw.
2. Lay the jack on its side and drain the fluid into a suitable container.

Note. Dispose of hydraulic fluid in accordance with local regulations.

3. Fill with oil until ~3/16" above the inner cylinder as seen from the oil filler hole. Reinstall oil filler plug/screw.

Lubrication

A periodic coating of light lubricating oil to pivot points, axles and hinges will help to prevent rust and assure that wheels, casters and pump assemblies move freely.

Cleaning

Periodically check the pump piston and ram for signs of rust or corrosion. Clean as needed and wipe with an oily cloth.

Note: Never use sandpaper or abrasive material on these surfaces!

Storage

When not in use, store the jack with saddle fully lowered.

REPLACEMENT PARTS

(refer to page 5 thru 7)

Not all components of the jack are replacement items, but are illustrated as a convenient reference of parts location. When ordering parts, give part number and parts description.

TROUBLESHOOTING

Symptom	Possible Causes	Corrective Action
Jack will not lift load	<ul style="list-style-type: none"> • Release valve not tightly closed • Overload condition 	<ul style="list-style-type: none"> • Ensure release valve tightly closed • Remedy overload condition
Jack will lift, but not maintain pressure	<ul style="list-style-type: none"> • Release valve not tightly closed • Overload condition • Hydraulic unit malfunction 	<ul style="list-style-type: none"> • Ensure release valve tightly closed • Remedy overload condition
Jack will not lower after unloading	<ul style="list-style-type: none"> • Reservoir overfilled • Linkage binding 	<ul style="list-style-type: none"> • Ensure load is removed, then drain fluid to proper level • Clean and lubricate moving parts
Poor lift performance	<ul style="list-style-type: none"> • Fluid level low • Air trapped in system 	<ul style="list-style-type: none"> • Ensure proper fluid level • With ram fully retracted, remove oil filler plug to let pressurized air escape, then reinstall oil filler plug
Will not lift to full extension	<ul style="list-style-type: none"> • Fluid level low 	<ul style="list-style-type: none"> • Ensure proper fluid level

Replacement Parts Illustration for model ATD-7390

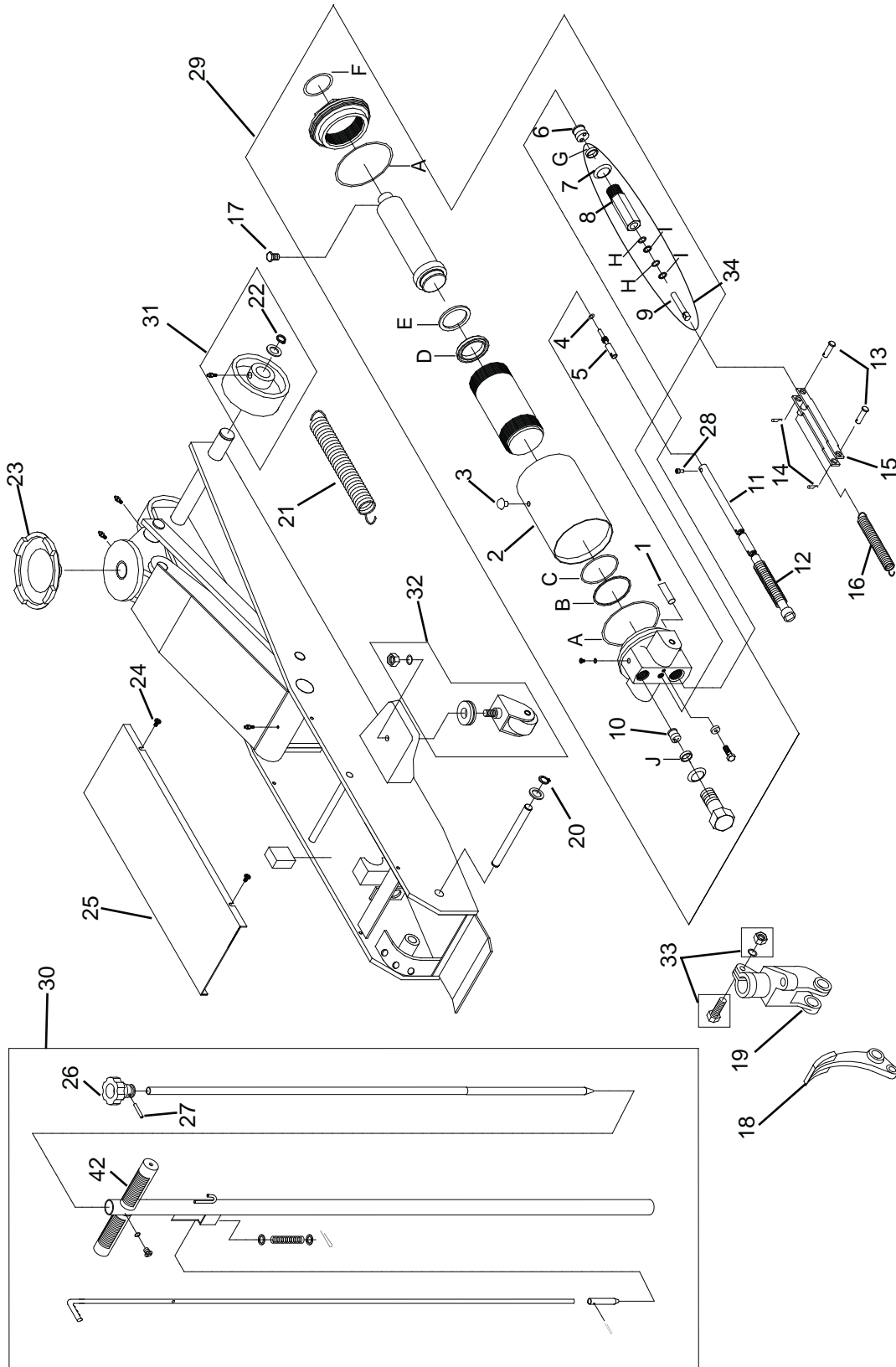

Figure 2 - Replacement Parts Illustration for model ATD-7390

Replacement Parts Illustration for model ATD-7391

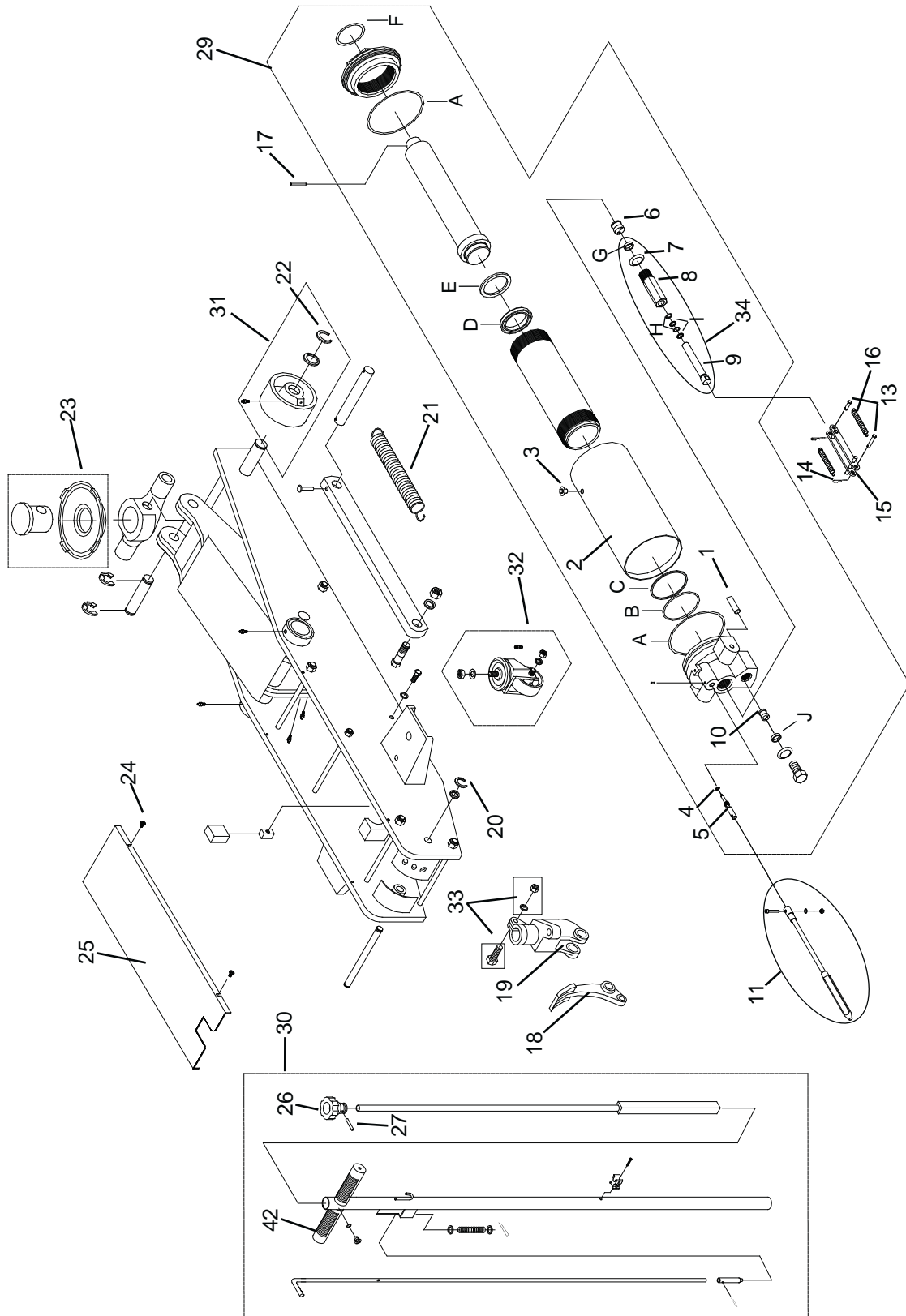

Figure 3 - Replacement Parts Illustration for model ATD-7391

Replacement Parts List for ATD-7390 and ATD-7391

Item	Part# for ATD-7390	Part# for ATD-7391	Description	Qty
1	G251-20008-000		Filter	1
2	G250-20002-000	G100-40003-000	Reservoir	1
3a	5905-00100-200	N/A	Filler Plug	1
3b	N/A	G62S-03301-000	Filler Screw	1
4	5901-00071-000		O-ring, D7.1x2.65	1
5	G250-20004-000	G251-20004-000	Release Valve	1
6	G250-24000-000	G100-43000-000	Hyd. Cartridge	1
7	B300-14002-000		Washer	1
8	G651-31002-000		Pump Cylinder	1
9	G651-31001-000		Pump Piston	1
10	G250-23000-000	G100-44000-000	Hyd. Cartridge	1
11	G250-30000-000	G100-90009-K04	Universal Joint	1
12	G251-00005-000	N/A	Spring	1
13	5405-12036-000	5405-12039-000	Pin	2
14	5405-02028-000		Retaining Pin	2
15	G250-50000-000	G100-70000-000	Piston Link	1
16	G251-00004-000	G100-00015-000 (2 pc.)	Return Spring, Pedal	1
17a	5110-06016-000	N/A	Screw	1
17b	N/A	5402-05025-000	Pin	1
18	G251-00009-000		Foot Pedal	1
19	G251-00010-000		Handle Fork	1
20	5304-00018-000		Snap Ring	2
21	G251-00003-000 (2 pc.)	G100-00014-000	Return Spring	1
22	5304-00028-000	5305-00024-000	Snap Ring	2
23	G251-00002-000	G100-90009-K02	Saddle	1
24	5110-06010-000	5111-55022-000	Screw, Philips	4
25	G250-00002-000	G100-00016-000	Cover	1
26	G251-40001-000		Knob	1
27	5402-04028-000		Spring Pin	1
28	5105-05012-000	N/A	Screw	1
29	G250-70000-000	G100-80000-000	Hyd. Power Unit	1
30	G250-40000-000	G100-90009-K01	Handle Assembly	1
31	G250-90004-K01	G100-90004-K02	Front Wheel Assembly	1
32	G250-90004-K02	G661-70000-000	Caster Assembly	1
33	G250-90009-K03		Bolt Assembly	1
34	G651-31000-000		Pump Assembly	1
*	G2501S-074 (includes 3a, 4 & A to J)	G1001S-97 (includes 4 & A to J)	Seal Kit for Hyd. Unit	1
-	ATD7390-L0	ATD7391-L0	Label (s)	-
-	ATD7390-M0		Manual	-

(*) Seal Kit Contents:

Item	Description	Qty
3a	Filler Plug (Atd-7390 only)	1
4	O-ring, D7.1x2.65	1
A	O-ring	2
B	O-ring	1
C	Back-up Washer	1
D	U-cup	1

Item	Description	Qty
E	Back-up Washer	1
F	O-ring	1
G	Packing	1
H	O-ring, D15x2.65	2
I	Back-up Washer	2
J	Packing	1