



Air Jack / Support Stand

Operating Instructions & Parts Manual

Model
ATD-7350

Capacity
10 Ton

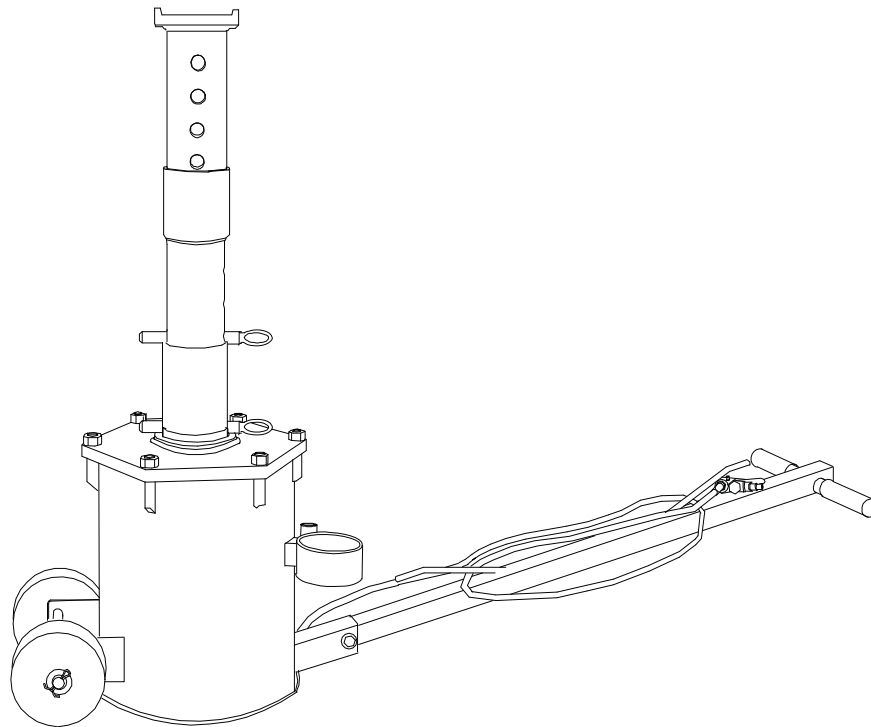

This is the safety alert symbol. It is used to alert you to potential personal injury hazards. Obey all safety messages that follow this symbol to avoid possible injury or death.

⚠ WARNING ⚠

WARNING: This product may contain chemicals, including lead, known to the State of California to cause cancer, birth defects or other reproductive harm. *Wash hands after handling.*

WARNING

- Study, understand, and follow all instructions before operating this device.
- Do not exceed rated capacity.
- Use only on hard, level surfaces.
- Lifting device only. Immediately after lifting, support the vehicle with appropriate means.
- Do not move or dolly loads with this device.
- Lift only on areas of the vehicle as specified by the vehicle manufacturer.
- No alterations shall be made to this product.
- Failure to heed these markings may result in personal injury and/or property damage.

ADVERTENCIA

- Leer, comprender, y seguir las instrucciones antes de utilizar el aparato.
- El manual de instrucciones y la información de seguridad deben estar comunicado en lengua del operador antes del uso.
- No seguir estas indicaciones puede causar daños personales o materiales.

SAFETY AND GENERAL INFORMATION

Save these instructions. For your safety *read, understand, and follow* the information provided with and on this jack. The owner and operator of this equipment shall have an understanding of this jack and safe operating procedures before attempting to use. The owner and operator shall be aware that use and repair of this product may require special skills and knowledge. Instructions and safety information shall be conveyed in the operator's native language before use of this jack is authorized. If any doubt exists as to the safe and proper use of this jack, remove from service immediately.

Inspect before each use. Do not use if broken, bent, cracked, or damaged parts (including labels) are noted. Any jack that appears damaged in any way, operates abnormally or is missing parts, shall be removed from service immediately and the manufacturer notified. If you suspect that the jack was subjected to a shock load (a load dropped suddenly, unexpectedly upon it), immediately discontinue use until the jack has been checked by a factory authorized service center (contact distributor or manufacturer for list of Authorized Service Centers). It is recommended that an annual inspection be done by qualified personnel. Replace worn or damaged parts with Factory Authorized Replacement Parts only. Labels and owner's manuals are available from manufacturer.

PRODUCT DESCRIPTION

The ATD Tools 10 Ton Air Jack/Support Stand is designed to lift and support rated capacity loads. **Intended use:** To lift one wheel or one axle of a vehicle for the purpose of service and/or repair of vehicle components. Use this jack in pairs when lifting an entire end of a vehicle. Check with vehicle owner's manual for proper lift points. Use one pair per vehicle.

 **WARNING:** *Rated capacity of this device is a reference to the working load this stand is capable of sustaining. Rated capacity is not increased when jacks are used in multiples.*

 **WARNING:** *Do not use for any purpose other than those uses outlined in this manual. **DO NOT** use jack around corrosive materials such as chlorides - commonly used by road crews to melt snow and ice. Water and slush from vehicles exposed to chlorides may enter jack cylinder, severely and permanently damaging interior of cylinder and causing air leaks which adversely affect lifting performance.*

SPECIFICATIONS

Model	Capacity	Starting Height	Max. Lift Height	Power Raise	Jack Size (L x W x H)	Rated Capacity Air Pressure	Weight
ATD-7350	10 Ton	17-1/2" to 40"	51-1/8"	11-1/2"	22" x 12" x 17"	200 psi	165 lbs.

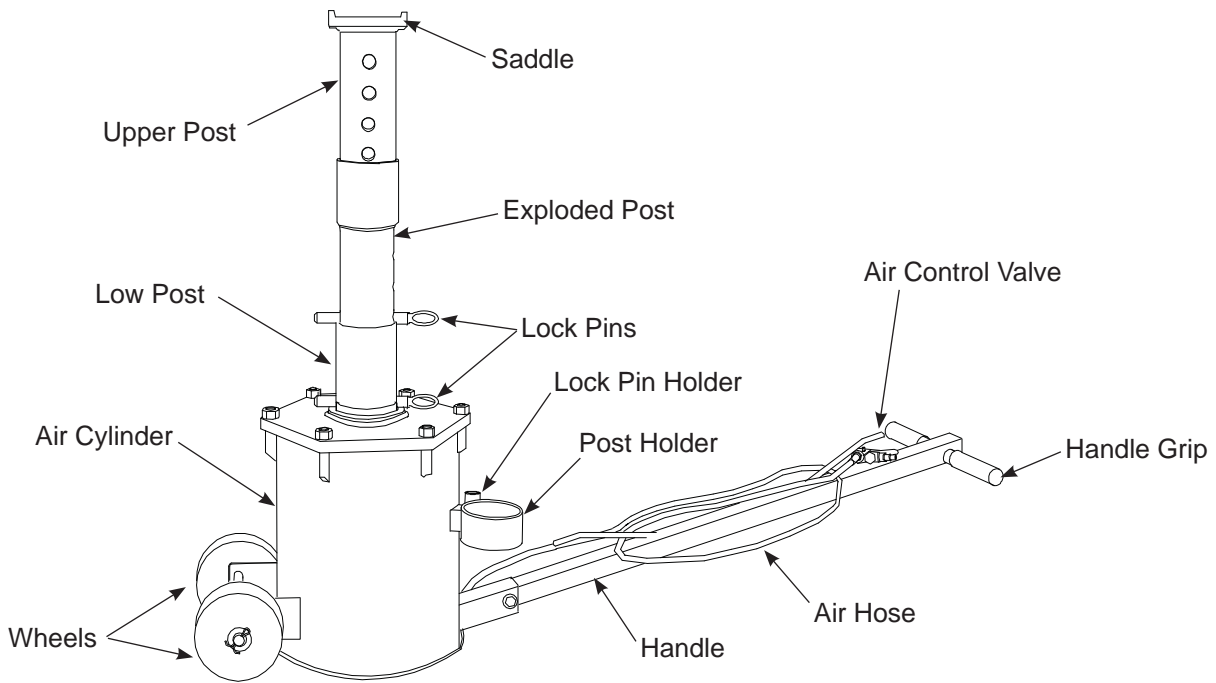

Figure 1 - Air Jack/Support Stand components

PREPARATION

Before Use

1. Verify that the product and application are compatible, if in doubt call for Technical Assistance.
2. Before use, read the operator's manual completely and familiarize yourself thoroughly with the product and its components, and recognize the potential hazards associated with its use. Know your jack and how it operates before attempting to use.

Assemble handle

Attached handle to the handle bracket on cylinder set with bolt and nut provided. Refer to parts drawing (page. 6) for component location.

Prepare air system

⚠ CAUTION: *Air source must not exceed 200 psi maximum.*

1. Connect a union fitting (sold separately) to the air supply inlet (ref. Fig. 2).
2. Attach 1/4" NPT coupler (sold separately) to union fitting if desired.
3. Frequent, but not excessive lubrication is required for best performance. Too much oil will collect inside jack and be expelled during exhaust cycle. An automatic inline oiler is recommended, but oil may be added manually before operation or after approximately 1 hour of continuous use. Pour 1 teaspoon of good quality air tool lubricant into air supply inlet of control valve.
4. Dirt and water may accumulate inside jack during use. An inline filter/dryer is recommended.
5. Air Jack/Support Stand is now ready for use.

⚠ WARNING: *Never use more than one extension with this unit. Using more than one extension causes the load to be lifted beyond the maximum designed safety lifting height, which could cause loss of load.*

Check the jack

1. Examine the jack for broken or damaged parts. Roll the jack to ensure that it rolls freely and smoothly.
2. Raise and lower the unloaded saddle throughout the lift range to ensure proper operation before placing any load on the product.
3. Replace worn or damaged components with factory replacement parts only. (See Replacement Parts Section). Lubricate as instructed in Maintenance Section.

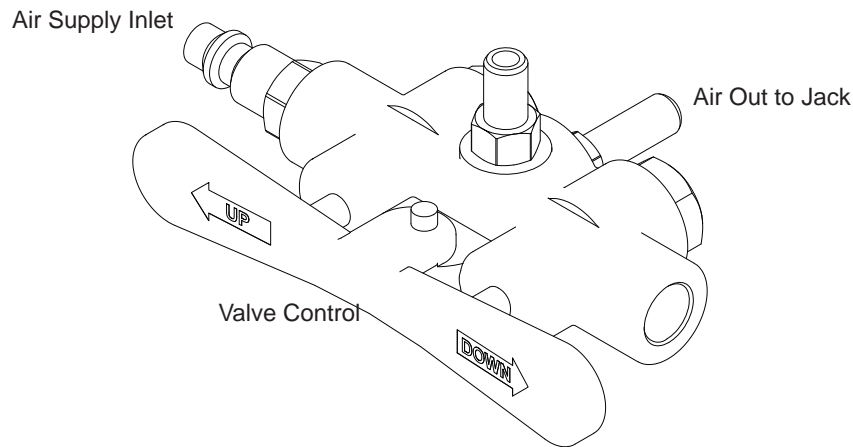

Figure 2 - Air Valve

OPERATION

Lifting

- ⚠ **WARNING:** *Only attachments and/or adapters supplied by the manufacturer shall be used.*
 - ⚠ **WARNING:** *Do not connect two jacks to one control valve. Operating the jacks in this way can cause of loss of control during raising and lower the vehicle.*
1. Follow the vehicle manufacturer's recommended guidelines for lifting.
 2. Position vehicle on hard level surface with parking brake selected. Chock wheels at opposite end. When lifting trailers, lower landing gear.
- ⚠ **WARNING:** *Do not attempt to raise a partially filled tanker or transport containing an unrestrained load. A sudden load shift can occur causing dangerous tilting or toppling of the vehicle.*
- NOTICE:** *Actuation of the air control valve will raise and lower the post.*
3. Position the unit under the lift point of the vehicle such that load will be centered on lifting saddle.
 4. Extend post to desired height and insert locking pin through appropriate hole. If necessary, use post extension for additional height. Post extension slides inside post and is held in place with safety pin (ref. parts drawing).
 5. Connect air compressor hose to control valve, then attach to air supply of 200 psi maximum. The unit is now ready to lift.
 6. Press the air control valve lever marked "UP" to raise post until it contacts vehicle lift point. Ensure lift point is secure and centered on lift post saddle.
 7. Press and hold air control valve until desired height has been achieved, insert the other lock pin through the hole in the ram post such that the lock pin will fully engage both sides of the head plate when lowered.
 8. Slowly release the air pressure and make sure the lock pin engages fully into both sides of the low post slot.
 9. Ensure the vehicle is level and stable, then fully discharge air pressure.
 10. Before working around the lifted vehicle, ensure the vehicle is level and stable between the jacks.
- ⚠ **WARNING:** *After lifting, never work on, under or around a load until the post is properly pinned and the air is exhausted. If the air is not exhausted and the jack is not properly pinned, the jack may rise or drop suddenly when a heavy object is removed from or placed on the vehicle.*

Lowering

⚠ WARNING: Check that all tools and personnel are clear before lowering load. Maintain control of speed at which load descends at all times.

1. Press the "UP" air control valve lever to raise post locking pin away from cap plate.
2. Ensure the vehicle is still stable, then remove lift post locking pin.
3. Press the "DOWN" air control lever to exhaust air pressure. Vehicle will gradually lower.
4. Discharge the air pressure from the jack fully once the vehicle is on the ground.
5. Ensure saddle is fully lowered, remove jack from under the vehicle and store properly.

TROUBLESHOOTING

Symptom	Possible Causes	Corrective Action
Air Jack will not lift load	<ul style="list-style-type: none"> • Inadequate air supply • Overload condition • Air line leaks 	<ul style="list-style-type: none"> • Ensure adequate air supply • Use larger capacity jack • Locate and seal leaks
Air Jack will not hold load	<ul style="list-style-type: none"> • Locking pin not engaged 	<ul style="list-style-type: none"> • Engage locking pin
Air Jack does not lift smoothly	<ul style="list-style-type: none"> • Cylinder requires lubrication 	<ul style="list-style-type: none"> • Apply #630-AAA Lubriplate to cylinder wall (see MAINTENANCE)

MAINTENANCE

The Air Jack/Support Stand is best operated with an in-line oiler. If using the jack without an oiler, complete the following steps before each use, or every hour is used continuously:

1. Disconnect the jack from the air hose.
2. Apply a few drops of good quality pneumatic tool oil through the air line.

Inspections should be made before each use of jack, checking for abnormal conditions. Regular inspections should be made weekly for daily use and monthly for intermittent use.

1. Inspect air hose for leaks or kinks. Replace if necessary.
2. Air control valve should operate freely. Wheels should rotate freely.
3. The post should extend and retract smoothly throughout its full range. If jack does not lift smoothly, remove bolts around cylinder cover, remove cover and lift piston weld assembly to the piston stops. Tilt the assembly to clear the piston stops. Clean and lubricate using #630-AAA-Lubriplate.
4. A periodic coating of light lubricating oil to all rotating and sliding portions of the jack will help to prevent rust and assure that the wheels move freely.
5. Lower the saddle to its lowest position when not in use.
6. When jack is not in use, tip it forward until it rests on the wheels and use extra support to hold the jack as shown in Figure 3. This allows trapped water to drain from inside the cylinder.

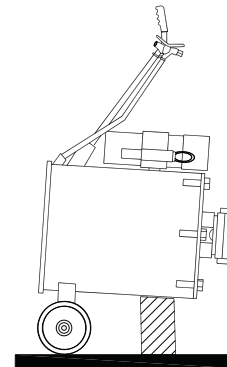
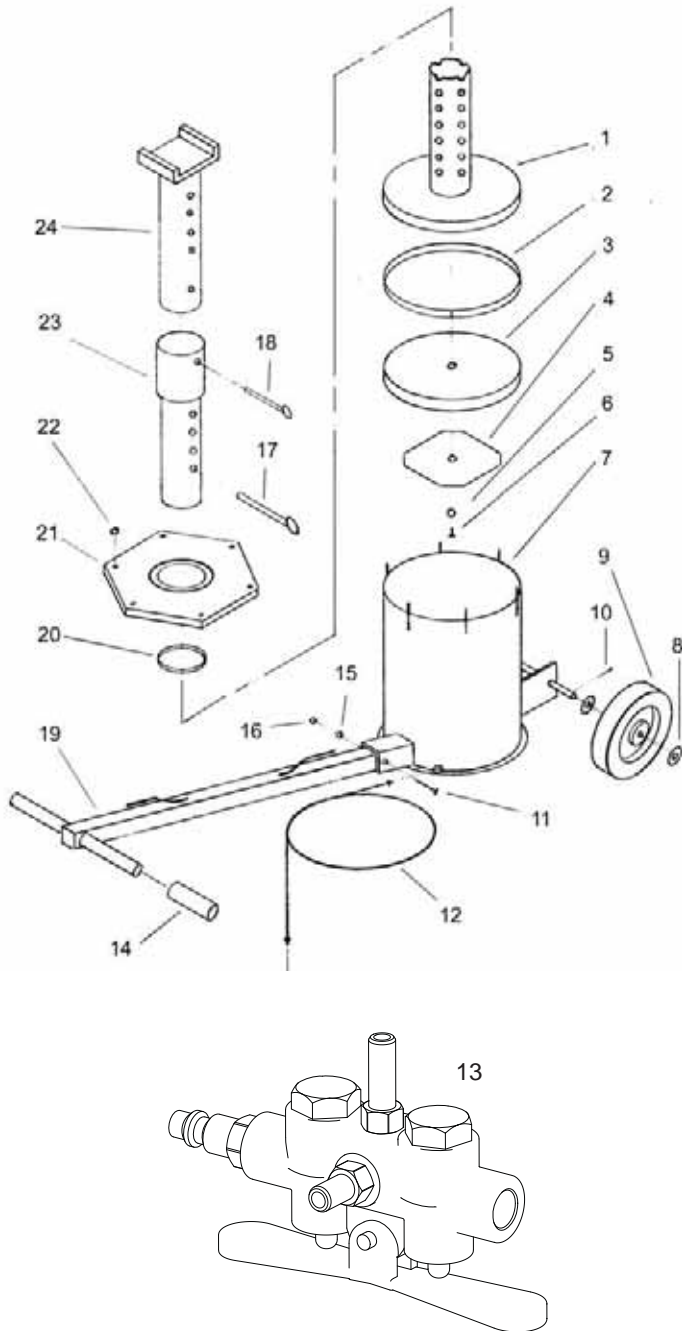

Figure 3

REPLACEMENT PARTS

Not all components of the jack are replacement items, but are illustrated as a convenient reference of location and position in the assembly sequence. When ordering parts, give model number, parts number and parts description. Contact your distributor for current pricing.



Replacement Parts List for ATD-7350

Item	Part#	Description	Qty.
1	34100-001	Low Post	1
2	34100-002	Gliding Ring	1
3	34100-003	Seal Ring	1
4	34100-004	Washer	1
5	34100-005	O-ring	1
6	34100-006	Bolt, M12 x 25	1
7	N/A	Air Cylinder Set	1
8	34100-007	Washer	4
9	34100-008	Wheel	2
10	34100-009	Pin, 5 x 30	2
11	34100-010	Bolt, M8 x 60	1
12	34100-011	3/8" Air Hose Set	1
13	34100-012	Air Control Valve	1
14	34100-013	Handle Grip	2
15	34100-014	Washer	1
16	34100-015	Nut, M8	1
17	34100-016	Locking Pin	2
18	34100-017	Safety Pin	1
19	34100-018	Handle Assy	1
20	34100-019	Guiding Ring	1
21	N/A	Cap Set	1
22	34100-020	Nut, M16	6
23	34100-021	Exploded Post	1
24	34100-022	Upper Post	1

Figure 4 - Parts Illustration for model ATD-7350