



ATD-7345B 2.5 Ton Aluminum PLUS Service Jack Owner's Manual



Features:

- The aluminum jack for everyday use
- The lightweight construction of aluminum with the strength of steel
- Aluminum frame with steel lift arm, handle fork and handle
- Side "D" handles for easy lifting
- Rubber saddle pad protects vehicle at lift point
- Swift Lift™ design offers a quicker lift for professional performance
- U-Joint release mechanism provides precise control of load descent in any handle position
- A built-in pressure release valve protects the hydraulic system from over pumping damage
- Meets or exceeds ASME/PASE 2014 standards

Specifications:

- Capacity: 2-1/2 Tons
- Minimum Height: 3.9"
- Maximum Height: 18.1"
- Handle Length: 49"
- Saddle Diameter: 4"
- Size: 26.1" x 12.1" x 6.25"
- Shipping Weight: 62.2 lbs.

SAFETY AND GENERAL INFORMATION

Save these instructions. You will need the manual for the safety warnings and precautions, assembly instructions, operating and maintenance procedures, parts list and diagram. Keep your invoice with this manual. Write the invoice number on the inside of the front cover. Keep the manual and invoice in a safe and dry place for future reference. For your safety, read, understand, and follow the information provided with and on this device before using. The owner and/ or operator should have an understanding of the device, its operating characteristics and safety operating instructions before operating the equipment. The owner and/or operator should be aware that use and repair of this product may require special skills and knowledge. Instructions and safety information should be read to and discussed with the operator in the operator's native language, making sure that the operator comprehends their contents, before use of this equipment is authorized. If any doubt exists as to the safe and proper use of this device, remove from service immediately

Always keep work area clean. Cluttered areas invite injuries. **Observe work area conditions.** Do not use machines or power tools in damp or wet locations Do not expose to rain. Keep work area well lighted. Do use electrically powered tools in the presence of flammable gases or liquids. **Keep children away.** Children must never be allowed in the work area. Do not let them handle machines, tools, or extension cords. **Store idle equipment.** When not in use, tools must be stored in dry location to inhibit rust. Always lock up tools and keep out of reach of children. **Use the right tool for the job.** Do not attempt to force a small tool or attachment to do the work of a larger industrial tool. There are certain applications for which this tool was designed. It will do the job better and more safely at the rate for which it was intended. Do not modify this tool and do not use this tool for a purpose for which is was not intended. **Dress properly.** Do not wear loose clothing or jewelry as they can be caught in moving parts. Protective, electrically non-conductive clothes and non-skid footwear are recommended when working. Wear restrictive hair covering to contain long hair. **Use eye and ear protection.** Always wear CE approved impact safety goggles. Wear a full face shield if you are producing metal filings or wood chips. **Do not overreach.** Keep proper footing and balance at all times. Do not reach over or across running machines.

Inspect before each use. Do not use if abnormal conditions such as cracked welds, damaged, loose or missing parts are noted. Any equipment that appears damaged in any way, is found to be worn, or operates abnormally should be removed from service until repaired. If the equipment has been or is suspected to have been subjected to an abnormal load or shock, immediately discontinue use until inspected by a factory authorized repair facility (contact distributor or manufacturer for list of authorized repair facilities). It is recommended that an annual inspection be made by an authorized repair facility. Labels and operator's manuals are available from the manufacturer.

 WARNING	
- Service Jack -	
<ul style="list-style-type: none">• <i>Study, understand, and follow all instructions before operating this device.</i>• Do not exceed rated capacity. <i>Know the weight of the load being lifted.</i>• Use jack only for lifting. <i>Do not use this equipment for any other purpose. Immediately after lifting, support the load with appropriate supporting equipment.</i>• Place jack correctly. <i>Only use this equipment on a surface that is stable, level, clean, dry, and capable of sustaining the load.</i>• Stabilize the load. <i>Ensure that the load remains stable at all times. Do not move load while on the jack. Lift deadweight loads only.</i>• <i>When lifting the vehicle, apply the emergency brake and block all wheels.</i>• <i>Lift only on areas of the vehicle as specified by the vehicle manufacturer. Center the load on the jack saddle. Off center loads can damage the seals, causing jack failure.</i>• <i>Never attempt to use the Jack unless it is properly filled with hydraulic fluid.</i>• <i>Do not move or dolly the vehicle while on the jack.</i>• <i>No alterations shall be made to this product.</i>• <i>Failure to heed these markings may result in personal injury and/or property damage.</i>	

PRODUCT DESCRIPTION

The ATD Service Jack is designed to lift, but not support, one end of a vehicle. Immediately after lifting, loads must be supported by a pair of appropriately rated jack stands. This service jack has a unique feature that provides fast, no load lifts to the jacking point. This jack has special built-in features that make it ideal for performing minor repairs, oil changes, cleanups, and more.

⚠ WARNING: Do not use hydraulic jack as stand-alone device. After lifting, immediately support the lifted vehicle with a pair of appropriately rated jack stands.

SPECIFICATIONS

Model	Capacity	Min. Height	Max. Height	Saddle Diameter	Jack Size (L x W x H)	Handle Length
ATD-7345B	2.5 Ton	3.9"	18.1	4"	26.1" x 12.1" x 6.25"	49"

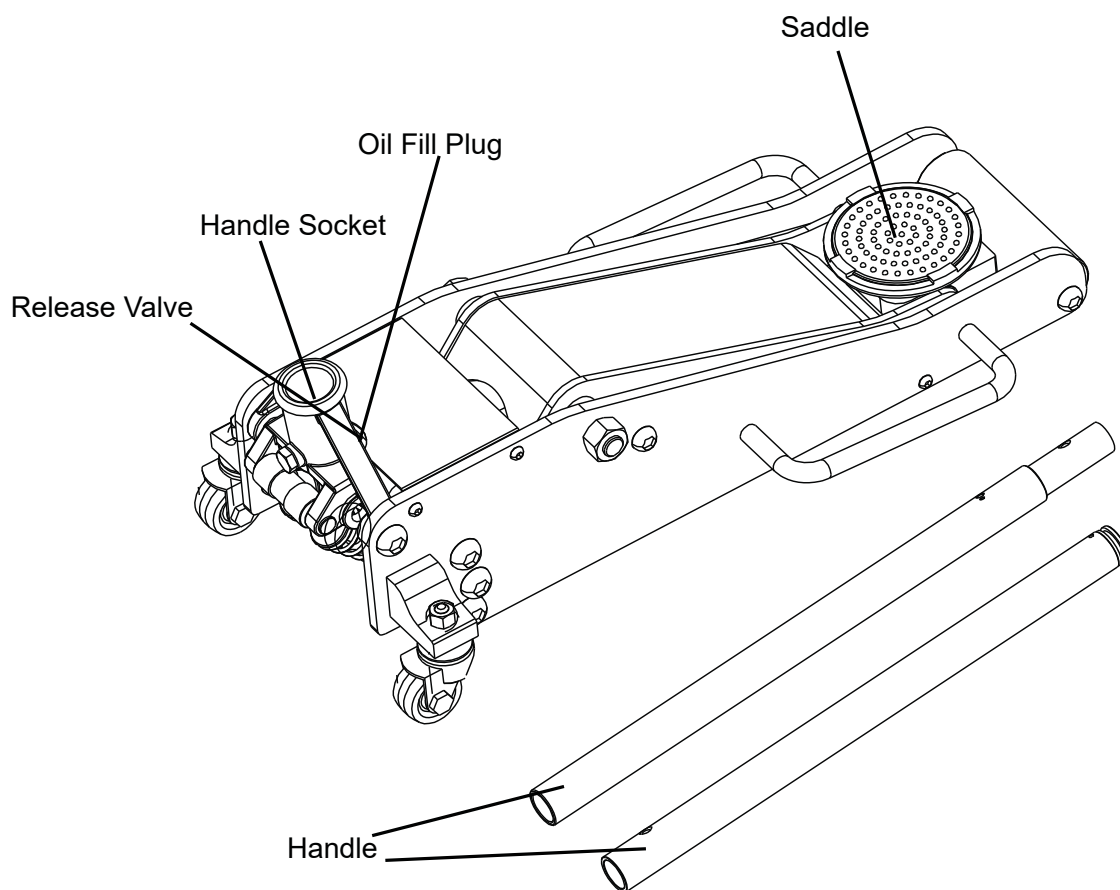

Figure 1 - Product Parts Illustration for ATD-7345B

PREPARATION

Unpacking

When unpacking, check to make sure that all of the parts are included. Refer to the parts lists and assembly drawings for more details. If any part is missing or damaged, do not attempt to assemble, install or operate the product. Contact your point of purchase.

Assembly

1. Remove the retaining clip: Press the socket down and then push the retaining clip out from the hole in the socket.
2. Handle Attachment: Push the handle fix bolt and insert upper handle into lower handle. Now turn parts until the handle fix bolt snaps in the hole. Loosen the handle set screw under the handle socket. Insert the handle into the handle socket until it locks in place and tighten the handle set screw again. After finishing the above steps, it will be no problem to operate the jack.

⚠ WARNING: Do not lift or carry jack by handle. Handle could dislodge and jack could fall, resulting in possible injury or property damage.

OPERATION

1. Test the jack by placing the saddle under a stable, dead load. Turn the handle completely clockwise, and pump the handle up and down. The jack saddle should rise and stay at that level. If it slowly goes down, tighten the oil plug. If it still goes down, the power unit may need to have the air purged from its system. Refer to the Maintenance Section.

⚠ WARNING: The jack, and equipment being lifted, must be stable so when lifted, they do not fall and cause personal injury. Keep spectators away from work area. Read the vehicle manual to find the proper lifting points for the vehicle.

2. Turn the handle clockwise. The saddle should lower completely.
3. Position the jack under the equipment being lifted.
4. Turn the handle clockwise to the release valve.
5. Pump the handle up and down until the saddle just touches the item being lifted. Readjust the saddle position so that the equipment is centered on the saddle.
6. Continue pumping until the jack is fully extended, or the equipment is lifted to the desired height.
7. Place the vehicle stands, or other support devices under the equipment before attempting to do any work in or around it.

CAUTION: AVOID RAPID DESCENT AND TO AVOID SPILLING OF THE LOAD, TURN THE HANDLE SLOWLY.

8. Slowly and carefully lower the load by turning the handle counterclockwise in extremely small increments.
9. When finished using the jack perform maintenance on it, and store the jack in a dry location.

MAINTENANCE

General

Periodically lubricate the jack as described below.

1. Lubricate the joints and ram with light oil as needed.
2. Remove handle and grease the lower end of the handle where it rotates in the handle socket.
3. Oil all lift arm linkages, front wheels, and rear casters.
4. Clean the outside of the jack with dry, clean cloth.
5. If the jack is exposed to moisture, wipe dry with a clean cloth and lubricate.
6. Store jack with piston ram withdrawn (saddle down), and in a clean and dry location.

Purging Air from the Hydraulic System

Air bubbles can become trapped inside the hydraulic system thereby reducing the efficiency of the jack . Purge the air from the system if the lift efficiency drops.

1. Turn the handle 1-1/2 turns counterclockwise.
2. Remove the oil plug by turning it counterclockwise.
3. Rapidly pump the handle assembly several times to purge the air from the hydraulic system.
4. Close the release valve by turning the handle completely clockwise
5. Be sure oil level is just below the threads in the oil fill plug hole. Replace and tighten the oil plug.
6. If efficiency is still low, remove oil plug and top off fluid reservoir in the aluminum base with hydraulic oil.
7. Replace the oil plug and repeat steps 1-5, above.
8. Wipe up any hydraulic oil overflow with a cloth.
9. Test the jack described under Operations (step 1 on page 4).

Oil Replacement

NOTICE: Use premium quality hydraulic jack oil. Avoid mixing different types of fluid and NEVER use brake fluid, turbine oil, transmission fluid, motor oil or glycerin. Improper fluid can cause premature failure of the jack and the potential for sudden and immediate loss of load.

1. Completely lower the saddle.
2. Place the jack on its side.
3. Remove the oil plug and drain old oil into a container.
4. Place jack upright and fill with high quality hydraulic jack oil to the lower rim of the fill hole.

5. Replace the oil plug.
6. Purge air from the hydraulic system as previously described.
7. Wipe up any hydraulic oil overflow with a cloth.
8. Contact the local hazardous waste disposal authority for proper oil disposal instructions.
9. **Maintain tools with care.** Always keep tools clean for better and safer performance. Follow instructions for lubricating and changing accessories. Inspect tool periodically and, if damaged, have them repaired by an authorized technician. The handles must be kept clean, dry, and free from oil and grease at all times.
10. **Stay alert.** Watch what you are doing, and use common sense. Do not operate any tools when you are tired or under the influence of drugs or alcohol.
11. **Check for damaged parts.** Before using any tool, any part that appears damaged should be carefully checked to determine that it will operate properly and perform its intended function. Check for alignment and binding of moving parts; and broken parts or mounting fixtures; and any other condition that may affect proper operation. Any part that is damaged should be properly repaired or replaced by a qualified technician.
12. **Replacement parts and accessories.** When servicing use only identical replacement parts. Use of any other parts will void the warranty. Only use accessories intended for use with this tool.
13. **Do not operate tool if under the influence of alcohol or drugs.** Read warning labels if taking prescription medication to determine if your judgement or reflexes are impaired while taking drugs. If there is any doubt, do not operate the tool.

⚠ WARNING: *The warnings, cautions, and instructions discussed in this instruction manual can not cover all possible conditions and situations that may occur. It must be understood by the operator that common sense and caution are factors which cannot be built into this product, but must be supplied by the operator.*

Lubrication

A periodic coating of light lubricating oil to pivot points, axles and hinges will help to prevent rust, and ensure that wheels, casters and pump assemblies move freely.

NOTICE: *Dispose of hydraulic fluid in accordance with local environmental regulations.*

Storage

When not in use, store the jack with saddle fully lowered.

Cleaning

Periodically check pump piston and ram for signs of rust or corrosion. Clean as needed and wipe with an oily cloth.

ATD-7345B REPLACEMENT PARTS

Not all components of the jack are replacement items, but are illustrated as a convenient reference for position in the assembly sequence. When ordering parts, give model number, part number and description. Call your distributor for current pricing:

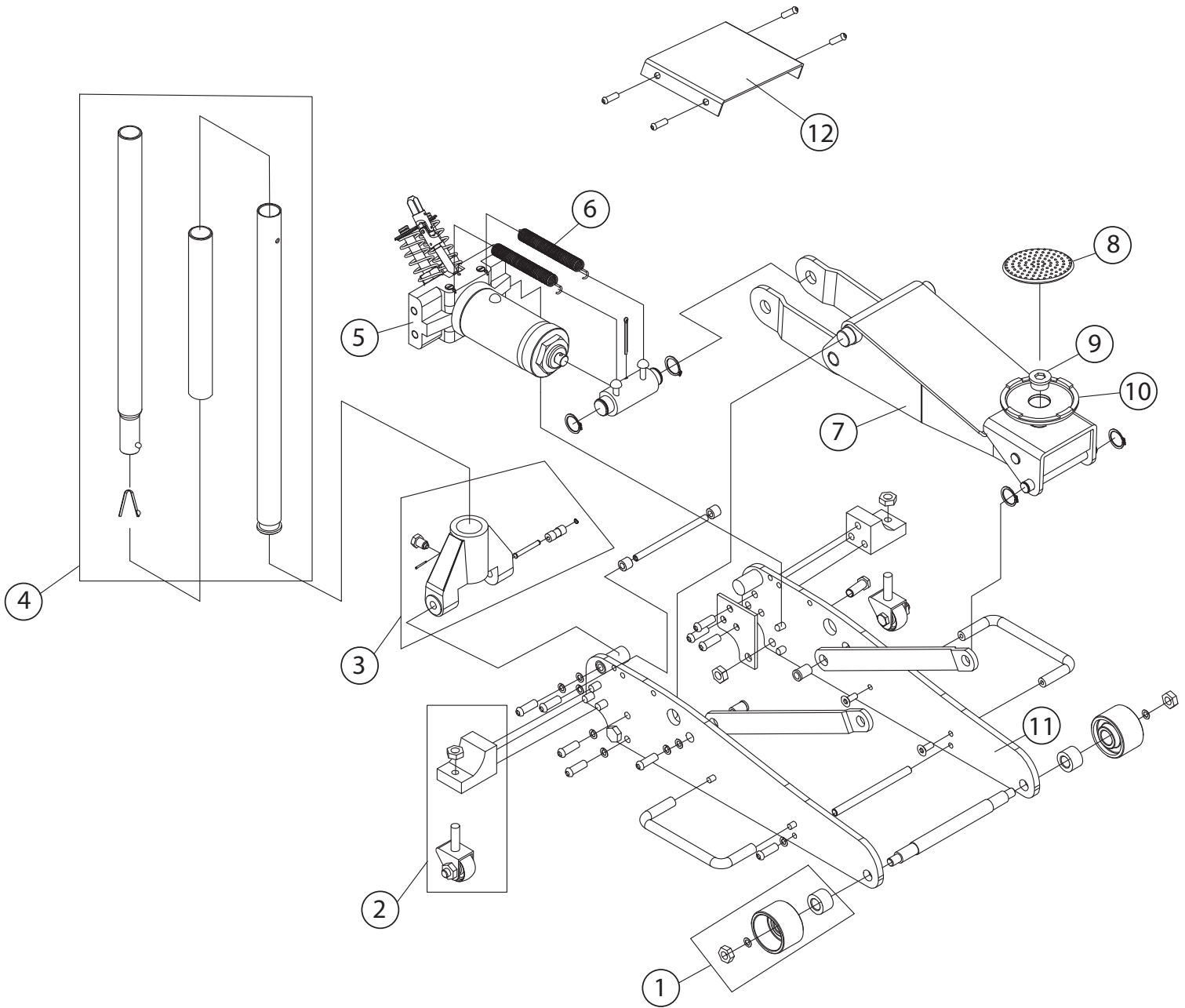

Figure 3 - Replacement Parts Illustration for model ATD-7345B Service Jack.
Please see the chart on the next page for part numbers.

ATD-7345B REPLACEMENT PARTS

Not all components of the jack are replacement items, but are illustrated as a convenient reference for position in the assembly sequence. When ordering parts, give model number, part number and description below.

ITEM#	ORDERING PART#	PART DESCRIPTION
1	PRT7345B-01	WHEEL ASSEMBLY
2	PRT7345B-02	REAR CASTER
3	PRT7345B-03	HANDLE SOCKET
4	PRT7345B-04	HANDLE ASSEMBLY
5	PRT7345B-05	HYDRAULIC POWER UNIT
6	PRT7345B-06	SPRING
7	PRT7345B-07	LIFTING ARM
8	PRT7345B-08	SADDLE PAD
9	PRT7345B-09	SADDLE PIN
10	PRT7345B-10	SADDLE
11	PRT7345B-11	SIDE FRAME
12	PRT7345B-12	COVER BOARD
N/S	PRT7345B-SK	SEAL KIT

**Replacement Parts for model ATD-7345B Service Jack.

Please see the diagram on the previous page for corresponding part numbers.**

PLEASE READ THE FOLLOWING CAREFULLY

THE MANUFACTURER AND/OR DISTRIBUTOR HAS PROVIDED THE PARTS DIAGRAM IN THIS MANUAL AS A REFERENCE TOOL ONLY. NEITHER THE MANUFACTURER NOR DISTRIBUTOR MAKES ANY REPRESENTATION OR WARRANTY OF ANY KIND TO THE BUYER THAT HE OR SHE IS QUALIFIED TO REPLACE ANY PARTS OF THE PRODUCT. IN FACT, THE MANUFACTURER AND/OR DISTRIBUTOR EXPRESSLY STATES THAT ALL REPAIRS AND PARTS REPLACEMENTS SHOULD BE UNDER TAKEN BY CERTIFIED AND LICENSED TECHNICIANS AND NOT BY THE BUYER. THE BUYER ASSUMES ALL RISK AND LIABILITY ARISING OUT OF HIS OR HER REPAIRS TO THE ORIGINAL PRODUCT OR REPLACEMENT PARTS THERETO, OR ARISING OUT OF HIS OR HER INSTALLATION OF REPLACEMENT PARTS THERETO.

TROUBLESHOOTING

Symptom	Possible Causes	Corrective Action
Jack will not lift load	<ul style="list-style-type: none"> • Release valve not tightly closed • Air is in hydraulic system • Load is too heavy • Low oil level • Power unit defective 	<ul style="list-style-type: none"> • Turn clockwise • Purge air from system • Consider higher capacity jack • Add oil as required • Replace power unit
Jack will not hold load	<ul style="list-style-type: none"> • Release valve not tightly closed • Hydraulic unit malfunction • Low oil level • Power unit defective 	<ul style="list-style-type: none"> • Ensure release valve is tightly closed • Add oil as required • Replace the power unit
Jack will not lower after unloading	<ul style="list-style-type: none"> • Reservoir overfilled • Linkages binding • Fluid level low 	<ul style="list-style-type: none"> • Drain fluid to proper level • Clean and lubricate moving parts • Ensure proper fluid level
Poor jack lifting	<ul style="list-style-type: none"> • Air is in hydraulic system • Low oil level • Power unit defective 	<ul style="list-style-type: none"> • Purge air from system • Add oil as required • Replace the power unit