

# ATD-5217 *MADE IN MEXICO* FOR 120 LB. DRUMS



## OWNERS MANUAL

### AIR OPERATED CHASSIS PUMP

**50:1 RATIO, OUTPUT – 80 CU. IN./MIN.**  
**MIN. AIR PRESSURE – 30 PSI**  
**MAX. AIR PRESSURE – 150 PSI**  
**MAX. OUTPUT PRESSURE – 7500 PSI**  
**RECOMMENDED OPERATING PRESSURE 80-100 PSI**  
**GREASE TYPE: NLGI #2** (maximum for effective performance)

**RETAIN THIS MANUAL FOR FUTURE REFERENCE TO IMPORTANT WARNINGS AND OPERATING AND MAINTENANCE INSTRUCTIONS.**

**PROPER USE AND MAINTENANCE OF THIS EQUIPMENT IS THE RESPONSIBILITY OF THE OWNER AND/OR OPERATOR.**

**DO NOT USE THIS EQUIPMENT UNLESS YOU HAVE CAREFULLY READ AND UNDERSTAND THE INSTRUCTIONS AND WARNINGS IN THIS MANUAL.**

### **! WARNING !**

**NEVER** exceed the stated maximum working pressure of the pump or of the lowest rated component in your system.

**NEVER** modify any part of this equipment.

**NEVER** use combustible gas with this equipment.

**NEVER** attempt repairs while the system is under pressure.

**NEVER** attempt to disassemble the equipment while the system is under pressure.

**ALWAYS** tighten fluid connections before using this equipment

**ALWAYS** read/follow the fluid manufacturer's recommendations regarding fluid compatibility.

**ALWAYS** read/follow the fluid manufacturer's recommendations regarding the use of protective clothing and equipment.

**ALWAYS** use an air line filter/moisture eliminator at the air inlet for the pump.

**ALWAYS** use air line lubrication.

**REGULARLY** check all equipment and repair/replace worn or damaged parts immediately.

**FAILURE TO HEED THESE WARNINGS INCLUDING OVERPRESSURIZING, ALTERING PARTS, USE OF INCOMPATIBLE FLUIDS, MISUSE, OR USE OF DAMAGED/WORN PARTS MAY RESULT IN EQUIPMENT DAMAGE, PROPERTY DAMAGE, FIRE, EXPLOSION AND/OR SERIOUS PERSONAL INJURY.**

### **SAFETY INSTRUCTIONS**

Extreme caution should be used when operating this equipment as it generates very high fluid pressure. Leaks from loose or ruptured components or material from dispensing valve can inject fluid through the skin causing serious bodily injury and possible need for amputation. Always wear protection to prevent material splashing onto skin or into eyes.

**IMPORTANT:** GET EMERGENCY MEDICAL CARE IMMEDIATELY IF ANY FLUID APPEARS TO PENETRATE THE SKIN! INFORM PHYSICIAN OF EXACTLY WHAT WAS INJECTED. PLEASE DO NOT TREAT THIS INJURY AS A SIMPLE CUT.

## ***! WARNING ! – RELIEF PROCEDURE***

**DO NOT EVER** point the dispensing valve at another person.

**DO NOT EVER** attempt to stop material from the dispensing valve or a leaking connection with your hand or body.

**BEFORE EACH USE**, check equipment for proper operation and to insure safety devices are in place and working properly.

**NEVER** modify this equipment. Modification could cause equipment malfunction and result in serious bodily injury.

**When flushing the pump with solvents, ALWAYS** hold a metal part of the dispensing valve firmly to the side of a grounded metal pail and operate pump at the lowest possible fluid pressure to reduce the risk of injury from splashing or static sparking.

**WARNING:** This pump can develop 7500 PSI working pressure at 120 PSI maximum incoming air pressure. Be sure that all system equipment and accessories are rated to withstand the maximum working pressure of this pump. **NEVER** exceed the maximum working pressure of the lowest rated component in the system.

**IMPORTANT:** “Whip” hoses for dispensing valve are fluid pressure rated at 4500 PIS. **NEVER** exceed 90 PSI, air pressure to pump when using “whip” hoses.

**WARNING:** Water and even moist air can cause this pump to corrode. To aid in the prevention of this corrosion, **NEVER** leave the pump filled with water or air. After normal flushing, flush the pump once more with mineral spirits or an oil based solvent, relieve pressure and leave the mineral spirits in the pump. **BE SURE TO CORRECTLY FOLLOW THE PRESSURE RELIEF PROCEDURE.**

### **PRESSURE RELIEF PROCEDURE**

**ALWAYS FOLLOW THIS PROCEDURE** to reduce the risk of serious bodily injury, including splashing into the eyes. After shutting off the pump; checking/servicing any part of the system; installing/cleaning or changing any part of the system, **ALWAYS** follow this procedure:

1. Disconnect the air supply to the pump.
2. Aim the dispensing valve away from yourself and others.
3. Aim the dispensing valve into an appropriate container and open until all pressure is relieved.

If you believe that the dispensing valve or hose is completely clogged or that pressure in the pump has not been fully relieved after following the above procedure, **VERY SLOWLY** loosen the hose end coupling to relieve the pressure gradually and then loosen completely. Then proceed to clear the valve or hose.

**WARNING:** ALWAYS follow the Pressure Relief Procedure after shutting off the pump.

**WARNING:** ALWAYS follow the Pressure Relief Procedure when checking/servicing any part of the system and when installing, cleaning or changing any part of the system.

### **INSPECTION INSTRUCTIONS**

If you believe that you have overpressurized the equipment, or if your equipment requires adjustments or repair, contact your Authorized Distributor or Service Center for inspection of the pump.

**ATD WARRANTY & SERVICE CENTER MAY BE CONTACTED AT 1-800-328-2897**

### **INSTALLATION**

It is recommended that you use an **air line filter/regulator/lubricator** to remove harmful dirt and moisture from the compressed air supply and to provide automatic lubrication to the air motor. **Blow-dry the lines and hoses with air before connecting them to the system..**

| <b>Instruction for Assembly of ATD-5217 Lubrigun</b>   |  |  |
|--|--|--|
| <b>Assemble Drum Cover to Pump</b>   | Insert end of pump tube (ATD-5217-1) through hole in the drum cover (45733). Line up holes in drum cover (45733) with the pump outlet body (ATD-5217-1). Place the screws (50060) in their respective holes in the drum cover (45733) and tighten drum cover (45733) to the bottom of the pump body (ATD-5217-1) |  |
| <b>NOTE:</b> Many of the smaller parts might have already been installed for you, such as the muffler (2601) pump cover (91407) and extension (10181).   |  |  |
| <b>Assemble</b> the four casters (66060ME) to the roll around base (ATD-5372)  |  |  |
| <b>1:</b> Place a fresh drum of lubricant centrally located on the roll around base between the four base clamps   | <b>2:</b> Base clamps are adjustable to fit the various diameter drums.  | <b>3:</b> Clamp drum rigidly to the base by tightening the clamp studs securely. |
| <b>Insert</b> follower plate (ATD-5325) onto the bottom of the pump tube (ATD-5217-1) and slide the follower plate (ATD-5325) up the pump tube.  |  |  |
| <b>Lower</b> pump tube into lubricant until drum cover (45733) rests on top bead of drum.  |  |  |
| <b>Insert</b> the three (3) adjusting screws (50415) into the drum cover (45733) and tighten securely to hold the pump (ATD-5217-1) to the drum.   |  |  |
| <b>Install</b> the muffler (ATD-5317)(not shown) in the exhaust port of the air motor head. Locate the muffler (ATD-5317) on the schematic. Ensure that the muffler (ATD-5317) is inserted in the correct orifice.   |  |  |
| Assemble the lubricant hose (ATD-5361) to the pump outlet body. If the union adapter (66645ME) was purchased, thread the union adapter into the lube opening followed by the hose (ATD-5361) into the union adapter. The connections must be <b>leakproof</b> . <b>Do not connect the ATD-5218 Control Valve Yet. You want to prime the system and purge contaminants out of the Grease Hose.</b>  |  |  |
| Install the extension tube (10181) into the air inlet port of the air motor. You might need Teflon tape to ensure a leak-free connection. Place air motor (91407) on pump head (ATD-5217-1). Place washer (33034) and cover nut (11478) on pump stud and thread air motor cover securely in place. Ensure that you align holes for 11660 air nipple and extension 10181.   |  |  |
| The Air coupler (815ME) and nipple (11660) are packed in a separate bag.   |  |  |
| Thread Air Nipple (11660) into extension (10181) connected through pump cover opening; Thread into pump head opening. Use Teflon tape to seal threads to prevent air leakage if necessary.   |  |  |
| Assemble air coupler (815) to an air hose of sufficient length so that the lubrigun can be moved to cover the entire lubrication area with the hose attached. When air coupler (815) is attached to air coupler nipple (11660), lubrigun is ready for operation. To release air coupler (815), draw back on the coupler sleeve (815) and slide away from the nipple (11660).   |  |  |
| <b>NOTE: DO NOT INSTALL ATD-5218 CONTROL VALVE YET!</b>  |  |  |
| <b>Did you install?</b>  | A regulator? We suggest that for accurate control of the pump, you use an air regulator.   |  |
| <b>DID YOU:</b>  | Purchase a Filter / Regulator for your pump? The Filter / Regulator should have an automatic dump mechanism to purge the water out of the incoming air. Water in the compressed air system is the biggest "Killer" of Air Operated Equipment.  |  |
| <b>YES:</b>  | Proceed  |  |
| <b>NO:</b>   | Think about it! It is cheap insurance to keep your pump running at maximum efficiency and the pump will last longer.   |  |
| <b>Initiating Air Motor and Pump Operation</b>   |  |  |
| <b>To Start Pump:</b> Turn on air from Air Regulator <b>slowly</b> . You will hear the air enter the air motor. Pump will start quickly and then reach prime at a stall pressure. It might take as much as 60-70 PSI to get the pump started initially. Recommended Air Pressure to operate the pump under normal conditions is 80PSI. Pump will activate as low as 15-20PSI. For first time operation, pump will start at 50-60 PSI. After that pump will activate at the lower pressure. |  |  |
| Pump will start quickly and then reach prime at a stall pressure when the control valve is attached.   |  |  |

**Allow pump to operate:** Pumping Grease into the hose. Allow approximately 1/3 Cup of Grease to flow out of the Hose. **This is to insure that any particles or contaminants or residue inside the hose do not enter the ATD-5218 Control Valve.** Stop Pump; **Install** the ATD-5218 Control Valve on the hose; The optional “Z” swivel (ATD-5253) can also be installed at this time. Make sure connections are tight; Resume operation of the pump. The pump should reach stall pressure and stop.

**Are you in a messy Environment?**

**The second biggest killer of these pumps is foreign material such as grit, dirt, rocks, metal shavings, grass, plastic shavings being introduced into the pump tube.**  
**We suggest the ATD-5356 pump tube strainer to avoid this problem.**

**Test the System**

**Pull the Trigger slowly and Grease should be ejected from the nozzle. Don't point it at anyone!**

**Never Put your Finger or Other Bodily parts near the valve control nozzle when pulling the trigger on the control valve ATD-5218.**

To know the amount of lubricant pressure in your system or the hose, multiply the amount of air pressure by 50. For example, if there is 100 psi of air pressure indicated on the regulator (100 psi of air entering) then there is 5000 psi of grease pressure in the lubricant line.

***Note: Plastic Liner***

If the grease gun has a plastic liner and your pump operates but no grease is delivered, the downtube of the pump could be trying to pick up the plastic liner and the downtube is blocked. **SOLUTION:** Reseat the pump in the grease by lifting the pump approximately 12” and reseating it on top of the drum. You can permanently raise the pump up at least 1”-2” out of the drum on blocks or install a grease strainer (ATD-5356) on the downtube to prevent the liner from being picked up.

***Note: Pump life & Air motor lubrication***

Please read the troubleshooting guide now. Your pump air motor has been packed with grease at the factory. In addition, approximately 4-8 fl oz's of common lubricating motor oil has been injected into the air inlet port of the air motor. To ensure the continuing operating efficiency and long life of your air motor pump, we recommend that you inject at least 2 fl oz's of common lubricating motor oil in the inlet port every week.  
**Do not use any synthetic oil like Marvel Mystery Oil. This will swell the Buna-N packings of the pump and cause irreparable damage to the pump.**

**Rev: 05-04-05**

# PORTABLE LUBRIGUN 120 LB DRUM SIZE 50:1 RATIO PUMP

## MODEL ATD5217

815 Coupler  
11660 Fitting

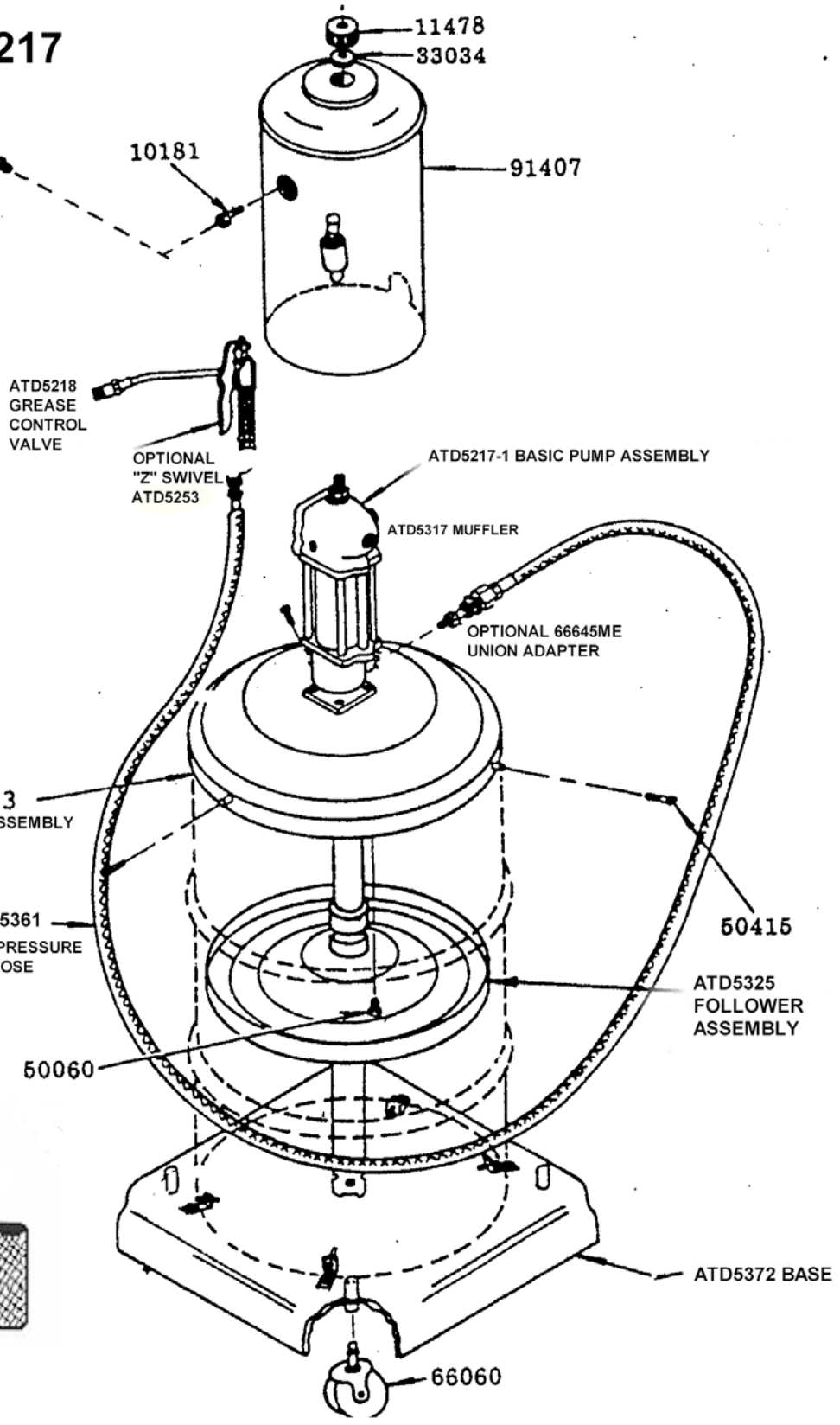

Additional Hose Lengths Available:

- 10FT: ATD5362
- 20FT: ATD5363
- 30FT: ATD5364
- 40FT: ATD5365
- 50FT: ATD5366

ATD5218  
GREASE  
CONTROL  
VALVE

OPTIONAL  
"Z" SWIVEL  
ATD5253

ATD5217-1 BASIC PUMP ASSEMBLY

ATD5317 MUFFLER

OPTIONAL 66645ME  
UNION ADAPTER

45733  
DRUM COVER ASSEMBLY

ATD5361  
6FT HIGH PRESSURE  
GREASE HOSE

50060

50415

ATD5325  
FOLLOWER  
ASSEMBLY

Grease Strainer  
ATD-5356 for  
Downtube

ATD5372 BASE

66060

# PUMP ASSEMBLY ATD-5217-1

Ⓒ INDICATES CHANGE

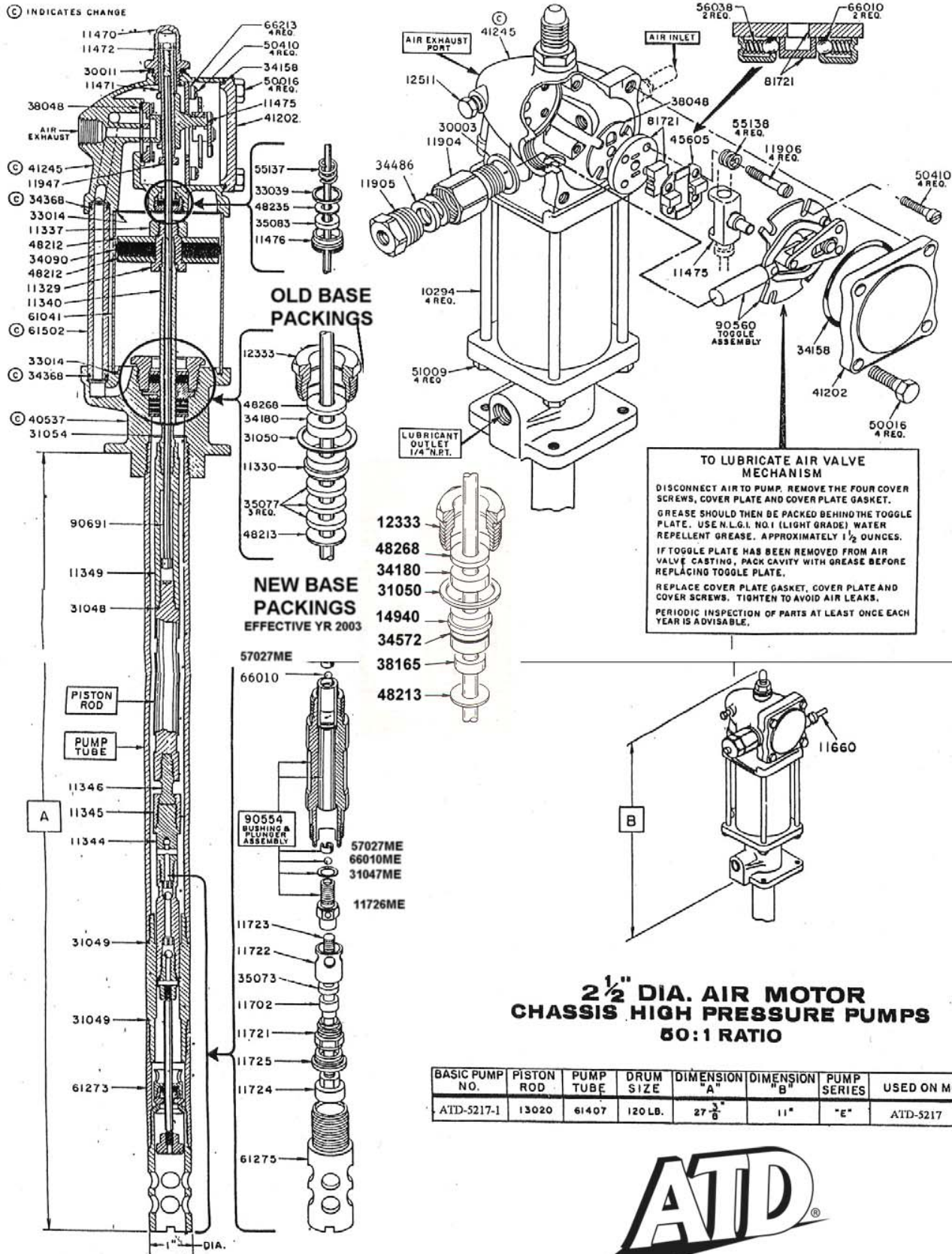

**TO LUBRICATE AIR VALVE MECHANISM**

DISCONNECT AIR TO PUMP. REMOVE THE FOUR COVER SCREWS, COVER PLATE AND COVER PLATE GASKET. GREASE SHOULD THEN BE PACKED BEHIND THE TOGGLE PLATE. USE N.L.G.I. NO.1 (LIGHT GRADE) WATER REPELLENT GREASE. APPROXIMATELY 1 1/2 OUNCES. IF TOGGLE PLATE HAS BEEN REMOVED FROM AIR VALVE CASTING, PACK CAVITY WITH GREASE BEFORE REPLACING TOGGLE PLATE. REPLACE COVER PLATE GASKET, COVER PLATE AND COVER SCREWS. TIGHTEN TO AVOID AIR LEAKS. PERIODIC INSPECTION OF PARTS AT LEAST ONCE EACH YEAR IS ADVISABLE.

**2 1/2" DIA. AIR MOTOR  
CHASSIS HIGH PRESSURE PUMPS  
50:1 RATIO**

| BASIC PUMP NO. | PISTON ROD | PUMP TUBE | DRUM SIZE | DIMENSION "A" | DIMENSION "B" | PUMP SERIES | USED ON MODELS |
|----------------|------------|-----------|-----------|---------------|---------------|-------------|----------------|
| ATD-5217-1     | 13020      | 61407     | 120 LB.   | 27 3/8"       | 11"           | "E"         | ATD-5217       |



**ATD-5217-1**

**2-1/2" AIR MOTOR OPERATED PUMPS**  
**MODEL ATD5217 Pump Assembly (ATD5217-1-Pump)**  
**(CHASSIS --- 50:1 RATIO)**

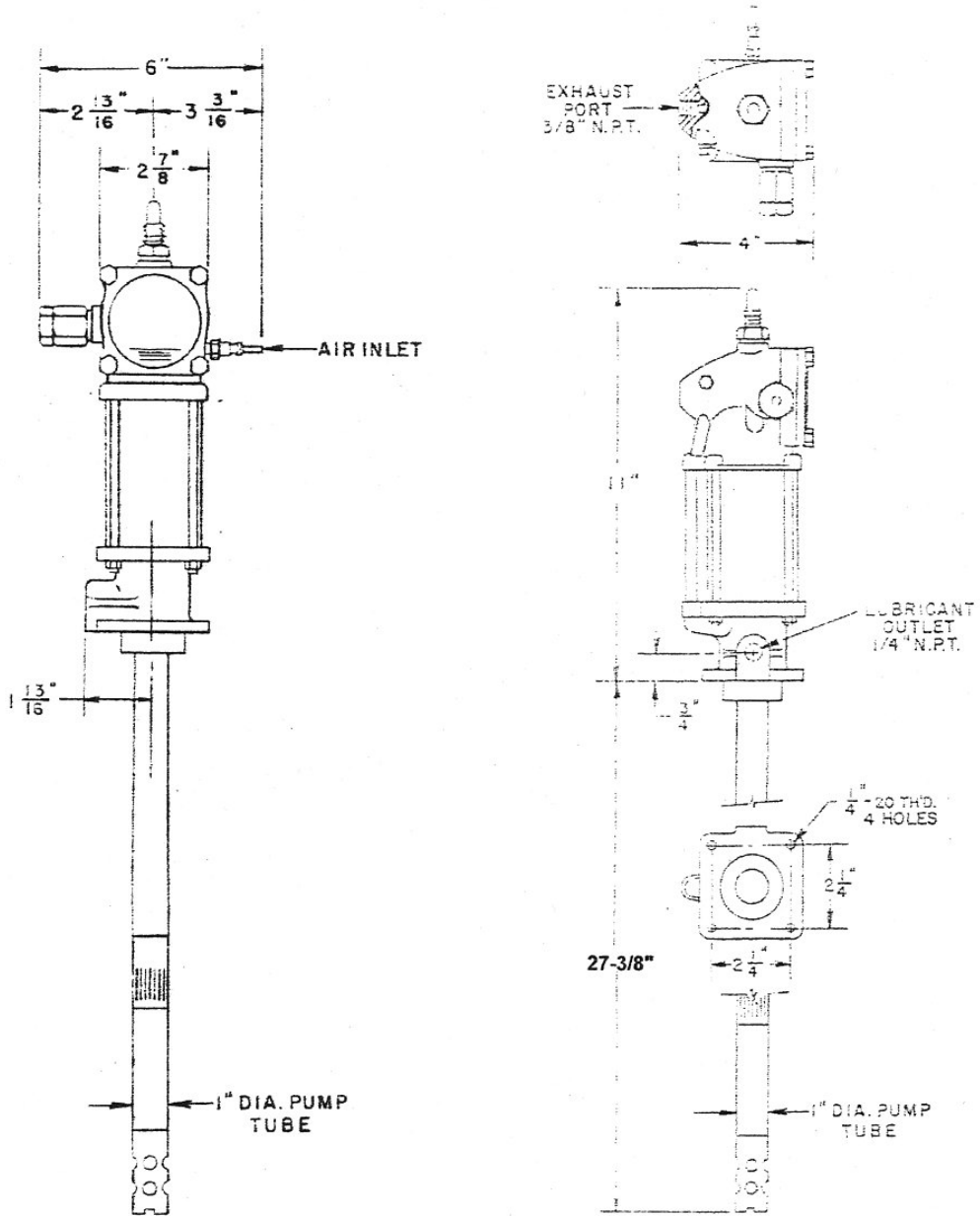

**REPAIR KITS AVAILABLE FOR**  
**SERVICING 2-1/2" AIR MOTOR HIGH PRESSURE PUMPS**

- Repair Kit No: **ATD5320** Simple Overall Repair Kit for Pump
- Repair Kit No: **R83054ME** Complex Overall Repair Kit for Pump
- Repair Kit No: **ATD5322** Air Motor Repair Kit
- Repair Kit No: **ATD5323** Down Tube Repair Kit

Service Instructions for ATD-5217 Pump Assembly (ATD-5217-1)

**Lubricate Air Valve Once Each Week with SAE 30 Common Motor Oil (only)**

**Servicing of Lower Pump Tube Assembly**

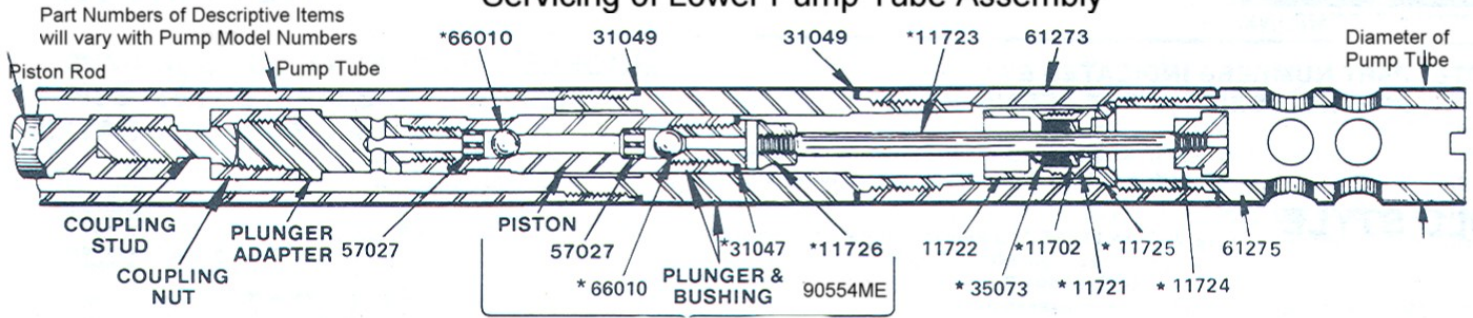

Loss of pressure, volume or continuous operation of pump when not in normal use indicates:

A. Foreign material lodged under Piston Ball Checks or between Upper and Lower Inlet Checks.

To correct this condition the Piston Ball Checks and Inlet Checks should be removed, thoroughly. If sealing surfaces between Upper and Lower Inlet Checks are rough or pitted, replace or resurface if damage is slight.

B. Shovel Rod Packing worn or damaged. Before installing new Packing, inspect surface of Shovel Rod and replace if rough or pitted. Do not grip Shovel Rod when disassembling lower pump tube assembly.

If pump continues to operate when not in normal use and lubricant level in drum drops, inspect lubricant supply line between pump and outlet for leaks or break in line.

**PARTS LIST FOR ATD5217 PUMP ASSEMBLY**

|       |   |           |                          |          |  |
|-------|---|-----------|--------------------------|----------|--|
| 10181 | EXTENSION TUBE                            | 11660ME   | AIR NIPPLE               | ATD-5218 | HP CONTROL VALVE   |
| 11478 | COVER NUT                                 | 45733ME   | DRUM COVER               | ATD5317  | MUFFLER  |
| 33034 | WASHER                                    | 66060M    | CASTERS/EACH             | ATD-5325 | FOLLOWER PLATE WITH RUBBER OUTER WIPING RING AND INNER RUBBER WIPING RING. |
| 50060 | MACHINE SCREWS FOR THE DRUM COVER (4 REQ) | 66060ME   | CASTERS(SET OF 4)        |          |  |
| 50415 | HOLD DOWN SCREWS FOR DRUM COVER(3 req)    | 815ME     | RAPID DISCONNECT COUPLER | ATD5361  | 6FT X 1/4" HIGH PRESSURE GREASE HOSE                                       |
| 91407 | COVER                                     | ATD5217-1 | 50:1 RATIO PUMP          | ATD-5372 | ROLL-A-ROUND BASE WITH CASTERS   |



**COMPLETE PUMP PARTS LIST; ATD-5217-1 FOR PUMP ASSEMBLY ATD5217**

| <b>PART #</b> | <b>DESCRIPTION</b>                       | <b>PART #</b>  | <b>DESCRIPTION</b>                                     | <b>PART #</b> | <b>DESCRIPTION</b>            |
|---------------|--|----------------|--|---------------|-------------------------------|
| 10294         | Tie Rod                                  | 12209          | Coupling Stud*   | 41202         | Cover Casting                 |
| 11329         | Air Piston Bolt                          | 12211          | Coupling Nut*  | 41245         | Air Valve Casting             |
| <b>11330</b>  | <b>Gland Spacer in Base(Old Version)</b> | 12333          | Gland Packing Nut                                      | 45605         | Valve Guide Plate             |
| 11337         | Air Piston Nut                           | 12511          | Pipe Plug  | 48213         | Gland Packing Washer          |
| 11340         | Air Motor Piston Rod                     | <b>14940ME</b> | <b>Gland Spacer in Base(New Version)</b>               | 48235         | Packing Washer                |
| 11344         | Plunger Adapter                          | 13020          | Piston Rod   | 34486         | O-Ring                        |
| 11345         | Coupling Nut                             | 13363          | Valve Cap  | 48237         | Plunger Packing Washer*       |
| 11346         | Coupling Stud                            | 30003          | Packing Nut Gasket                                     | 48268         | Gland Packing Washer*         |
| 11349         | Piston Rod Connector                     | 30011          | Valve Cap Gasket                                       | T-2489        | Valve Cover Screw*            |
| 11470         | Valve Cap                                | 31047          | Check Seat Gasket*                                     | 50016         | Valve Cover Screw             |
| 11471         | Trip Rod Collar                          | 31048          | Connector Gasket                                       | 50410         | Toggle Plate Screw            |
| 11472         | Trip Rod Pin                             | 31049          | Bushing Gasket   | 51009         | Tie Rod Nut                   |
| 11475         | Trip Shoe                                | 31050          | Gland Gasket   | 55137         | Trip Rod Packing Spring       |
| 11476         | Trip Rod Packing Nut                     | 31054          | Pump Tube Gasket                                       | 55138         | Valve Seat Spring             |
| 11660         | Air Inlet Nipple                         | 33014          | Air Cylinder Gasket                                    | 56038         | Spring                        |
| 11702         | Check Washer                             | 33039          | Packing Nut Gasket                                     | 57027         | Ball Stop                     |
| 11721         | Priming Check                            | 34090          | Air Piston Packing                                     | 61041         | Air Cylinder                  |
| 11722         | Check Stop                               | 2-206          | Plunger Packing*                                       | 61273         | Bushing Extension             |
| 11723         | Plunger Rod                              | 34158          | Cover Gasket   | 61275         | Priming Tube                  |
|               |  | 34180          | Gland Packing  | 61321         | Pump Tube*                    |
| 11724         | Priming Plunger                          | 34368          | O-Ring   | 61407         | Pump Tube                     |
| 11725         | Priming Check Seat                       | <b>34572ME</b> | <b>O-RING Base Packings NEW VERSION</b>                | 61502         | Air Passage Tube              |
| 11726         | Check Seat*                              | 35073          | Priming Check Packing                                  | 66010         | Equalizer Ball                |
| 11761         | Piston Rod                               | <b>35077</b>   | <b>Gland Packing Base Packings(Old Version)(3 req)</b> | 81721         | Valve Slide and Seat Assembly |
| 11904         | Packing Nut                              | 35083          | Trip Rod Packing                                       | 90554         | Plunger and Bushing Assembly  |
|               |  | 38048          | Valve Seat Gasket                                      | 90560         | Toggle Plate Assembly         |
| 11905         | Packing Cap                              | 38162          | Valve Seat Gasket*                                     | 90691         | Trip Rod Assembly             |
| 11906         | Valve Seat Bolt                          | <b>38165ME</b> | <b>U-CUP BASE PACKINGS NEW VERSION</b>                 | 12210         | Coupling Adapter*             |
| 11947         | Trip Sleeve                              | 40537          | Outlet Body  | 48212         | Air Piston Washer             |

## Trouble Shooting Guide for Pumps

### ATD-5289-1 - ATD-5217-1 -- ATD-5219-1

| PROBLEM:  | SOLUTION:   |   |   |
|---|---|---|---|
| <b><i>WARNING: OUCH!</i></b>  | <b><i>THINK SAFETY FIRST!!!!</i></b><br><b><i>THINK SAFETY ALWAYS!!!</i></b>  |   |   |
| Your pump does not work? There are Three Basic Problems!  | Air Motor Operates but nothing comes out. This is the most common problem.  | Air Motor Operates; Grease comes out but there is no pressure. 2nd Common Prob.       | Air Motor does not operate. This is a less common occurrence. |
| We will deal with all 3 of these problems and step you through a troubleshooting sequence so <b><i>you can solve the problem on your own without our intervention and be on your way.</i></b> All of the pumps undergo 2 types of stringent tests at the factory; the first is a cycle test in grease with the pump pumping a certain amount of grease per cycle over a stated time period. The second test is a pressure test with a meter to hold grease pressure at 5000 psi at 100 psi of air pressure for a stated period of time before they leave the factory. This ensures that your pump will work out of the box. |   |   |   |
| <b><i>Warning:</i></b>  | If the Air is connected to the pump, <b><i>consider the pump to be live.</i></b> Do not attempt to work on the pump or the system without disconnecting the Air Inlet and relieving pressure in the system, both air pressure and lube pressure. Make sure there are no live air pockets in the air motor and all air has been bled from the Air Motor before working on the pump.  |   |   |
| <b><i>Warning: (Again!!!)</i></b>   | Ensure that all of the Air Pressure and Lubrication Pressure has been bled out of the system and there is no Residual Lube Pressure or Air Pressure in the System before you disassemble the pump!! (VERY IMPORTANT!!!!)  |   |   |
| <b><i>Warning:</i></b>  | Do not stick your finger into the bottom of the Pump Downtube or 61275 Priming Tube. This could result in amputation!!  |   |   |
| <b><i>Warning:</i></b>  | Do not stick any type of blunt instrument into the bottom of the Pump Downtube or 61275 Priming Tube as this could ruin or bend the precision parts such as the 11723 Plunger Rod.  |   |   |
| Question  | Yes   | No  |   |
| Does the Air Motor Operate?   | Next Section  | Check In-Line Air Pressure to the pump. Recommended Air Pressure is 80 PSI – 100 PSI. |   |
|   |   | Check Air Compressor and FRL for obstructions or blockage                             |   |
| Is the Air Motor is Leaking Air?  | Check the Inlet Air Nipple. Use Teflon tape to seal the threads at the Air Inlet. Silicon is not recommended since it can escape into the interior of the Air Motor and cause damage to the valves. Check the Quick Disconnect Coupler connection to the Air Hose. Use Teflon tape to seal the threads at the Connection  |   |   |
| The Air Motor blows air through the Muffler / Exhaust Port  | Check to see that the Air Inlet Nipple is installed in the correct location. Check that the Brass/Steel Plug is installed in the Air Motor head and is not leaking air. If there are no air leaks and Air is fully engaged at least 80 psi, then sometimes in RARE CASES the slide valve will stick in the neutral position: take the rubber part of a mallet and slightly tap the top of the Air Motor or the cover of the Air Motor (41202) with the rubber part only. Did we say “ <b>LIGHTLY TAP</b> ” Yes, we did.<br><b>Don’t pound it and Don’t beat it!!! It is an Casting and It will dent or Crack!</b> Sometimes and very rarely the slide Valve sticks in the neutral position and needs to be prodded off of the neutral position. It also indicates that the Air Motor might have water damage or the damage is starting or there is water present in the air line. |   |   |
| <b>Question (???)</b> Are you using a <b>Filter / Regulator/Lubricator (FRL)</b> on the pump?   | <b>Answer:</b> We strongly suggest the use of a Filter / Regulator/Lubricator (FRL) on the pump. The Filter should be a moisture evaporator with an automatic dump on it so water is eliminated and purged from the air before entering the pump. If you do not have a FRL on the pump, chances are the pump head could be accumulating water and this will corrode the inside of the pump and moving parts, thereby reducing the life of the pump.   |   |   |
| Pump does not pump material   | Check to see if there are any blockages in the Lubricant lines. If all lines are secure: disconnect the Grease Hose from the pump.  |   |   |

|   |  |  |
|---|--|--|
| Pump operates, pumps material but does not shut off.  | Reason: Pump is not reaching stall pressure.<br>1: Check that all hoses, lubricant lines and controls valves are connected and the connections are tight. There should be no leaks.<br>2: Check that the hoses are <b>SAE approved Grease Hoses</b> and made for pumping High Pressure Grease. <b>Don't use Oil Hose or Garden Hose for pumping High Pressure Grease.</b><br>3: Go to Step #2; Downtube Blockage.<br>4: If that does not solve the problem go to Step #4 |  |
| Air Motor on Pump operates but no material comes out  | 1: Check the follower plate.<br>Make sure there are no air pockets in the grease underneath the follower plate. Push down lightly on the follower plate to ensure a positive prime.<br>2: Check that all hoses and control valves are fully connected<br>3: Check to see that there are no blockages in the lines, hoses or control valves.<br>4: Go to Step #2; Downtube Blockage below.<br>5: If that does not solve the problem go to Step #4 below                   |  |
| Air Motor still Operates but no Material comes out.   | Your Pump has picked up some foreign debris or materials such as rocks, stones, dirt, sand, plastic or metal. Follow instructions for Lower Downtube Disassembly and Cleaning below.   |  |
| <b>Pump, hoses and valves are Connected and pump does not Pump when I pull the trigger on The control valve</b> | <b>See Trouble Shooting Sequence Below: Question / Answer Period.</b>  |  |
| <b>Warning: (Again!!!)</b>  | <b>If the Air is connected to the pump, consider the pump to be live. Do not attempt to work on the pump or the system without disconnecting the Air Inlet and relieving pressure in the system, both air pressure and lube pressure. Make sure there are no live air pockets in the air motor and all air has been bled from the Air Motor.</b>   |  |
| <b>QUESTION???</b>  | <b>YES!!!</b>  | <b>NO!!!</b>   |
| Does the pump Air Motor operate when it is removed from the Grease?   | If yes, then put the pump back in the grease. Remove the hose from the pump  | If no, then check Air Inlet for Pressure, and check Air Motor for Leaks at the Air Nipple, Muffler or Seals. If there are no air leaks and Air is fully engaged at least 80 psi, take the rubber part of a mallet and slightly tap the front cover of the Air Motor (41202) with the rubber part only.<br>Sometimes and very rarely the Toggle Valve sticks and needs to be prodded off of the neutral position. |
| Does the Air Motor have water in the Casing?  | If water is in the Air Motor Casing (41245), The slide valve 45605 could be sticking because it is corroded or rusted. Sometimes injecting 4-8oz of SAE 30 Motor Oil into the air Air Inlet will lubricate the air motor parts enough to get the air motor operating. This is a temporary fix.   |  |
| Water Continued: Oil Solution   | Do not use Marvel Mystery Oil or any synthetic oil as this will swell the Buna N Packings of the pump and render the pump useless.   |  |
| Does the Air Motor Operate Now?   | If yes, now check to see it will pump grease. In the future keep the air motor well oiled. You need to check the water and air quality in your air line. Insert pump into grease and see below <b>Step 5:</b>  | No! this could be due to 2 problems; We will deal with each independently. <b>See Sept #1 Below and then see Step #2 .</b>   |
| <b>Step #1: Water in the Air Motor<br/>Step #2: Downtube Blockage.</b>  | <b>Yes:</b> Remove Air Motor Cover 41202 and inspect the inside of the Air Motor Casing. There should be   | <b>No,</b> we did not find water in the Air Motor Casing when we removed the Air Motor Cover 41202. <b>Go to Step #2 below.</b>  |

|  |  |  |
|--|--|--|
|  | <p>NLGI#1 Grease packed into the air motor casing. If there is no grease in the air motor casing, the grease is white or the parts are corroded and rusted you have a moisture problem in your air line that needs to be corrected.</p> <p>Try soaking the Air Motor Casing in SAE 30 Motor Oil to free up the moving parts. If this does not solve the problem the pump needs to be rebuilt preferably by an Authorized ATD Service Center.</p> | <p><b>Step #2:</b> It is possible your pump has picked up some foreign materials or debris such as rocks, stones, dirt, sand, plastic or metal. This could block the down tube plunger 11724 from being able to freely move up and down. Follow instructions for Lower Down tube Disassembly, Inspection and Cleaning.</p>   |
| <p><b>Step 3: Did this solve the problem?</b></p>                        | <p>Yes, Please think of using a Strainer (ATD5356) See Note on the Strainer Below.</p>   | <p>No!; If this did not solve the problem with the pump, then we have covered blockage in the downtube, corroded or non-function parts in the air motor, blockage in the hose and control valve, and air motor air leaks.. This covers approximately 99% of the problems. Continue to Step #4 if the pump does not build or hold pressure or continue onto step #6 for unusual problems.</p>   |
| <p><b>Step 4: Pump not holding or building Pressure:</b></p>             | <p>Yes, the pump holds pressure fine. Then you solved the problem?!?!?</p>   | <p>No, it operates but does not hold or build pressure in the system or line.</p> <p><b>Follow instruction for Lower Downtube Disassembly, Inspection and Cleaning.</b> Chances are foreign material is lodged in the lower downtube. In addition, it is possible that the packing 35073 needs to be replaced in the Lower Downtube section. This is a wear part and not covered by warranty. Consult your service manual for the location of the 35073 and instructions for replacement are in the Downtube Disassembly instructions.</p> <p>In some cases, we have seen paper and bubble gum that get stuck up inside the plunger bushing 90554ME between the two check balls, check seats and ball stop. This part is a precision lapped part and if that is the case, it will need to be cleaned out. <b>See note below on types of foreign materials.</b></p> |
| <p><b>Step 5: Does it pump grease now when inserted in the drum?</b></p> | <p>Yes? There is a blockage in the Hose or the Control Valve. Remove the Control Valve from the hose and connect the hose to the pump. Or Yes, but it does not seem to hold or build pressure. <b>See note below on types of foreign materials.</b></p>  | <p>No? See Step # 1 followed by Step #2</p>  |
| <p>Does the grease pump through the hose?</p>                            | <p>Yes? Then the blockage is in the Control Valve. Attach the control valve to the hose. Remove the coupler from the Control Valve. Most likely the blockage is at the control valve.</p>  | <p>No? Then the blockage is in the hose.</p>   |
| <p>Does the grease pump through the Control Valve?</p>                   | <p>If yes, there was blockage in the coupler of the control valve. Clean the Coupler out with Mineral Spirits.</p>   | <p>If no, there is a blockage in the main body of the Control Valve. Control Valve needs to be disassembled and cleaned.</p>   |

|  |  |   |
|--|--|---|
| <b><i>Is there Blockage in your Lubricant Lines, Hoses, Pumps and Control Valves Common?</i></b> | If yes, we suggest the use of a foot valve strainer: <b>ATD-5356</b>   |   |
| <b><i>Step #6: Are there Dents in the Air Cylinder?</i></b>                                      | Yes, Look on the outside of the air cylinder 61041 . Are there any dents. The smallest dent will stop the operation of the pump. You need to replace that part and order a repair kit as well. Or Contact an Authorized ATD- Service Center. Also see warning note below on the use of Hammers!  | No. there are no dents or cracks on the outside. Go to step #7: |
| <b><i>Step #7: Any Synthetic Oil?</i></b>  | Has anyone injected marvel mystery oil or any synthetic oil into the air inlet of the pump. Synthetic Oil will swell the Buna N Packings especially part # 34090. The Air Motor will not operate and will need to be rebuilt.  |   |
| <b><i>Note: Strainer ATD-5356</i></b>  | To prevent Blockage in the pump, hose, lubricant lines or control valve with contaminated grease, or to prevent contaminated grease from entering your bearings, we suggest the use of a Grease Strainer: ATD-5356   |   |
| Has your Pump been Outside in the elements? Has water entered the Air Motor?                     | If yes, there is a possibility that water has accumulated inside the Air Motor. Over time this can cause damage to the Air Motor. All pumps are packed at the factory with a water repellent NLGI #1 grease. Over time with water accumulating inside the Air Motor, the grease can be flushed out.  |   |
| <b><i>Note: FRL</i></b>  | To ensure the proper operation of your Pneumatic pump, we suggest a <b>Filter, Regulator, Lubricator (FRL)</b> on each Pump OR at the very least a Filter /Regulator with an automatic dump mechanism on it to purge water out of the air.   |   |
| <b><i>Note: Hammer Fix!!</i></b>   | Don't Bang on the pump with a hammer or blunt instrument. The pumps are rugged and made for professional and industrial use but are made of Aluminum and if any parts are dented, it will affect the operation of the pump.  |   |
| <b><i>Note: Types of Foreign Materials:</i></b>  | Some foreign materials such as adhesives, caulks, anything w/ sugar, bubble gum, abrasive materials can ruin or severely block part # 90554ME. This is a precision lapped bushing and plunger assembly that can wear excessively when it is exposed to abrasive materials such as sugar, dirt and sand. If this does occur, you will probably have to replace part # 90554ME.  |   |
| <b><i>Note: Plastic Liner Issues</i></b>   | If the Grease Drum/Pail has a Plastic Liner and your pump operates but no grease is delivered, the downtube of the pump could be trying to pick up the plastic liner and the downtube is blocked:<br><b>SOLUTION:</b><br>1: You can try reseating the pump by lifting the pump approximately 6-12 inches above the drum / pail and reseating it on top of the drum / pail.<br>2: You can try raise the pump up at least 1-2" out of the drum on blocks but might introduce contamination in the grease with blowing dirt etc.... ; Also you will leave 1-2" of grease in the bottom when you change containers.<br>3: Install a grease strainer (ATD-5356) on the downtube to prevent the liner from being picked up.<br>4: In recent years, manufacturers have made their liners with a heavy plastic and this has not been an issue. |   |
| <b><i>Final Warning on a Live Pump::</i></b>   | <b>If the Air is connected to the pump, consider the pump to be live. Do not attempt to work on the pump or the system without disconnecting the Air Inlet and relieving pressure in the system, both air pressure and lube pressure. Make sure there are no live air pockets in the air motor and all air has been bled from the Air Motor.</b>   |   |
| <b><u>Revision: January 23, 2008</u></b>   |  |   |

# Lower Pump Tube Disassembly and Cleaning Instructions

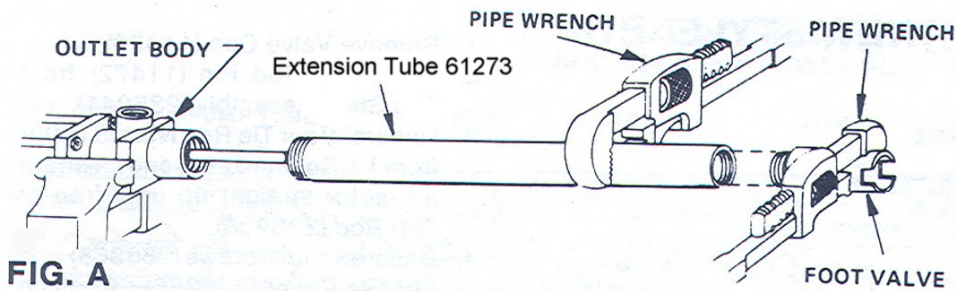

FIG. A

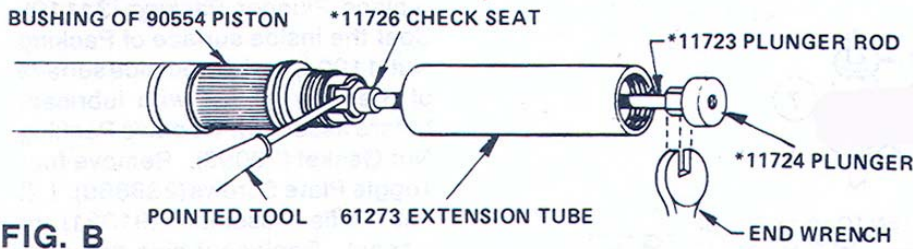

FIG. B

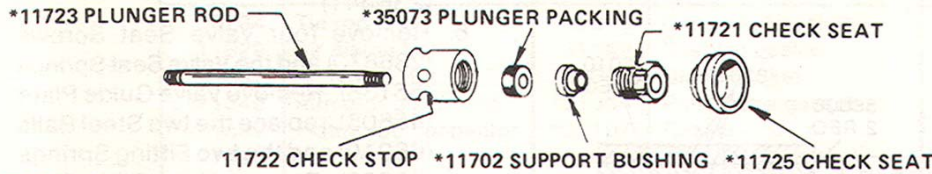

FIG. C

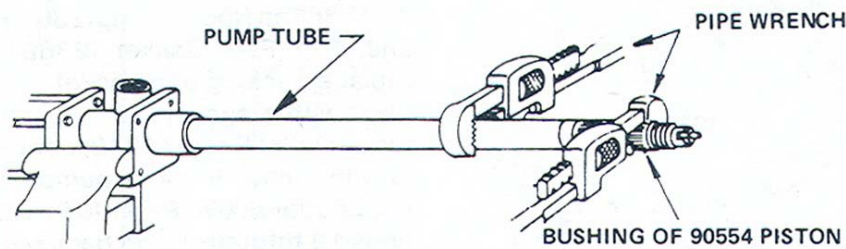

FIG. D

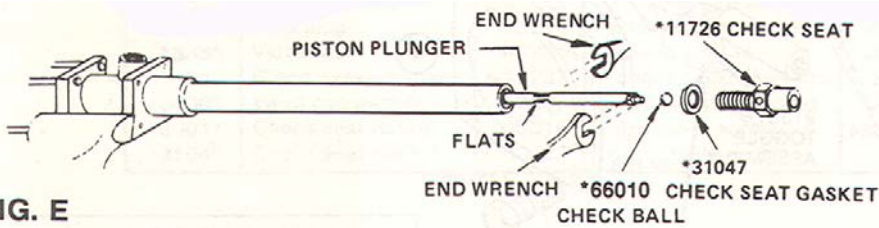

FIG. E

**Cleaning:** Use Mineral Spirits and a Brush to Thoroughly Clean all Debris out of the Foot Valve 61275 and Extension Tube 61273; Thoroughly inspect all parts for wear or damage; Clean all Parts

## Tentative Check List

- 1: Is the Plunger Rod 11723 bent?
- 2: Is the Packing 35073 excessively worn?
- 3: Is the Check Seat 11725 worn or has abrasions or cuts?
- 4: Is the plunger 11724 bent or broken?
- 5: 95% of the problems with the pump not pumping material; not holding pressure or not operating have to do with foreign Material such as Rocks, Stones, Metal, Nuts, Bolts, Plastic, Paper, Gum and other materials being picked up by the downtube and getting caught in the extension tube or the down tube. When Changing Lube Containers, Watch where you lay the pump and what the downtube touches. Anything will stick to the grease on the end of the downtube.

**95% of the problems** that occur with the pump not pumping material; not holding pressure or not operating at all have to do with foreign Material such as Rocks, Stones, Metal, Nuts, Bolts, Plastic, Paper and other materials being picked up by the downtube and lodging themselves in the extension tube or the down tube.

To avoid this, use a strainer for the downtube, if in a difficult environment. In rare cases with paper and bubble gum, the material can work its way up into the bushing and plunger assembly (90554) and therefore this part needs to be disassembled and cleaned as well. If sand or dirt is a constant problem, you will find that the bushing and plunger assembly will wear excessively. These two pieces are lapped and fitted together as one. Constant Sand or Dirt passing through the part 90554 Bushing and Plunger can ruin the tight fit.

## Procedure

**FIG A.** (See Fig. A) Lay pump horizontal in vise and grip outlet body tightly in vise jaws. Hold Extension Tube (61273) and unscrew Priming Tube (61275).

**Fig B.** (See Fig. B) Pull Plunger (11724) straight out until Plunger Rod (11723) is extended as far as possible out of the Extension Tube (61273). Hold bushing of Piston (90554) and unscrew Extension Tube (61273).

Center Extension Tube (61273) between end of piston bushing and Plunger (11724). Insert any pointed tool in through hole at Base of Check Seat 11726.

**Note:** Plunger may unscrew from Plunger Rod (11723) or plunger rod may unscrew from Check Seat (11726). Extension Tube (61273) can be removed from free end of Plunger Rod (11723).

**Fig C:** (See Fig. C) When you remove the Extension Tube (61273) this exposes the Check Seat (11725), Priming Check (11721), Check Stop (11722), Support Bushing (11702) and Plunger Packing (35073).

**Note:** Unscrew Priming Check Seat (11721) from Check Stop (11722) to remove Support Bushing (11702) and Plunger Packing (35073); To do this you will have to put Check Seat (11721) in a vise and insert a point tool such as a punch through the holes in Check Stop (11722) to unthread Check Stop (11722) from Check Seat (11721).

Plunger Packing (35073) incurs heavy wear and it is advisable to replace this part if worn.

Perform this only if you need to remove Bushing and Plunger Assembly; Otherwise Reassembly Pump Tube

**Fig D.** (See Fig. D) Removing Bushing and Plunger Assembly (90554ME); Hold pump tube and unscrew bushing of Piston (90554). Bushing should slide off once unthreaded from the Pump Tube.

**Fig E.** Grip two flats at top of piston plunger with an end wrench and remove Check Seat (11726).

**Note #1:** Check Ball (66010) may remain in plunger after Check Seat (11726) is removed. To remove check ball tilt pump in vise and gently tap top of plunger at location of two flats.

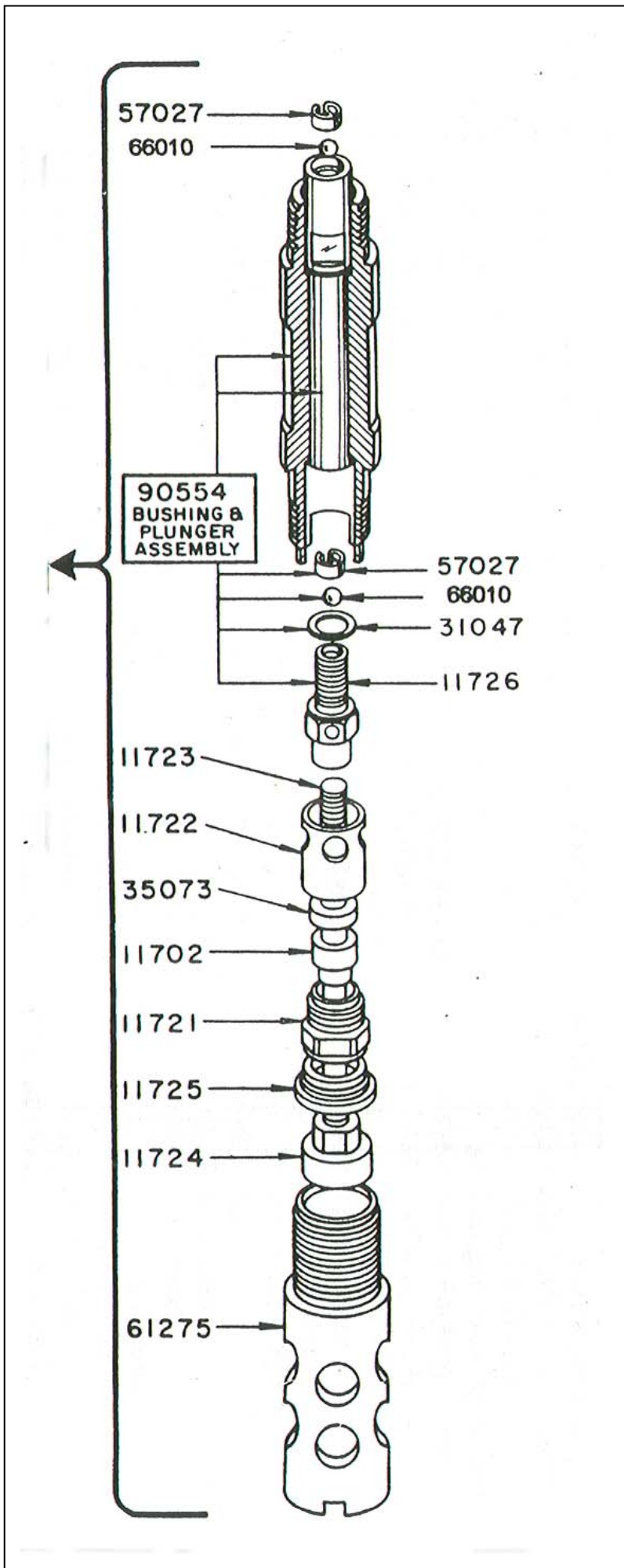

**Note #2:** You only remove that check ball (66010) if you suspect foreign material is behind the check ball. You can perform a visual inspection after the check ball is removed and if there is foreign debris behind the check ball, then continue and remove the bushing and plunger assembly as well. (See below).

Occasionally debris such as **paper, bubble gum, plastic, cellophane, plastic bags etc.** have gotten wedged up inside the plunger portion of the bushing and plunger assembly. Flats are provided on the plunger portion to remove the complete plunger and inspect the inside.

This removal will also facilitate the easy extraction of the ball cage 57027 and ball 66010 at either end of the plunger. Be sure to note the order of installation of the plunger assembly on the pump rod (ie which is the top and which is the bottom). Don't confuse the two. If you reverse the plunger, the pump will not work correctly. **Again, don't confuse the top and bottom of the plunger.** Once you remove the two (2) ball cages 57027 and the 2 balls 66010, you should be able to look directly through a clean orifice inside the plunger assembly. If not, then something is blocking the inside of the plunger assembly and it must be removed. Do not scratch the machined surfaces of the plunger or the inside of the bushing. Normally the item in the plunger is of a nature similar to the materials mentioned above in bold. This is not a common occurrence to have material stuck or wedged in the plunger assembly but it has happened.

When reassembling the plunger assembly, **NOTE #1:** The top and bottom of the plunger assembly. You were careful in the beginning and noted it when you took it apart. **NOTE #2:** notice the order of the ball and cage. Starting from the bottom, it is ball ; cage; then at the top of the plunger it is cage; ball; If you reverse this order, the pump will not operate at all.

Now use the flats on the plunger and thread the top portion of the plunger onto the coupling (different number for different pumps). Tighten the plunger but don't strip the threads.

Next prepare to insert the plunger into the bushing by pushing the bushing into the plunger rod. Please note the bushing and plunger are a lapped pair and they are fitted at the factory. You cannot take a plunger from one pair and change it with another bushing. The fit is a tight fit. Make sure the Bushing is straight before you attempt to slide it on. The bushing should just slide on. A Bit of grease inside the bushing or on the plunger will help the insertion. Thread the bushing 90554ME onto the pump tube. Tighten securely.

The gasket ring 31047 and 11726 is inserted onto the bottom of the plunger. Use the milled flats to tighten 11726. Assemble the balance of the items in reverse order to disassembly. Note the drawing to the left. When reinstalling the bushing extension 61273(not shown), install the unit over the other interior parts and let it hang loose. Thread the rod 11723 onto the bottom of 11726. To tighten the rod, you will have to insert a small punch into the hole of 11726. See Fig B on page 1. We are now tightening the rod 11723 by putting a wrench on the plunger 11724. Assemble balance of items as shown.

Tighten all outside parts securely with wrench.

## **Additional Instructions: with some tips to help you**

### **Cleaning out the Downtube with Foreign Material and Debris Pumps: ATD-5289-1; ATD-5217-1; ATD-5219-1**

You need to have the plunger all the way extended to the end of the foot valve before you start. It makes life easier. Put a small amount of air on the unit to extend it out. When it is extended out to the bottom of the foot valve, disconnect the air.

Start with Figure "A" in the attached photo description sheet. Do not unthread the pump tube. You don't need to even though it indicates the same in the sketch.

Take off the Foot Valve 61275.

#2: Unscrew the extension tube 61273; Do not Yank it out. You will need a pipe wrench to unthread the extension tube; actually two; one on the bushing and plunger assembly piece (90554ME) to hold it steady and the other on the extension tube to unthread the extension tube off of the end of the Bushing and Plunger Assembly.

Stick the pointed tool (usually a punch of the correct diameter) in the check seat hole of 11726 and use an adjustable wrench on the plunger. .

Once the plunger is off of the plunger rod (it is unthreaded) you can slide the complete unit off. Sometimes the rod 11723 unthreads from the the check seat 11726, that is fine as well. If there are dirt, rocks, metal or plastic in that area, clean it out. While you have it off, replace the plunger packing 35073. We offer Buna N (black), Viton(Brown) and Teflon(White). It is a wear part.

Do not unthread the bushing and plunger assembly unless you suspect there is obstruction problems. If paper, bubble gum, plastic gets into the bushing and plunger assembly you will have to clean out the inside of the plunger. The debris usually gets caught in the ball cages. Note the order of the ball cage in the plunger assembly on the drawing. If you put it in reverse order the pump will not pump grease. Starting from the bottom of the pump tube, it is ball, cage, ball cage. Look at the drawing on page 2 and you will understand.

Assemble the unit back in the reverse order.

**Normally, we pump mineral spirits through a completed repair job to clean it out and test the pump. The mineral spirits should be pumping out on the up and down stroke. Mineral Spirits is easier than grease if you have to disassemble the pump again because a part or parts was installed incorrectly.**



# ATD5217

## Description

### 120 Drum Grease Pump Assembly:

1. Includes 50:1 Double Acting High Pressure Pump(ATD5217-1)
2. 6'(1.85mts) High Pressure Grease Delivery Hose(ATD5361)
3. Grease Delivery Control Valve(ATD5218)
4. Rapid Disconnect Coupler(LT815ME)
5. Muffler(ATD5317)
6. Pump Tube Length made for 120 lb Drum & 1.0" Diameter
7. Follower Plate (with outer rubber wiping ring on the drum and inner rubber wiping ring on the pump tube)Diameter 1.0"(ATD5325)
8. Air Motor Cover(91407ME)
9. Steel Drum Cover with screw downs for 120 LB Drum(45733ME)
10. Roll-a-Around Base with 4 casters for easy maneuverability(ATD5372)
11. Steel Drum Not Included.
12. Weight: 48LBS (21.8KG)
13. Box Dimensions: Length: 39.0"(100cm) X Width:19-1/2"(49.5cm) X Height: 8.0"(20.32cm)
14. Complete Repair Kits Available(See Below).
15. Two Year Warranty against Materials, Workmanship and Labor
16. These high pressure Grease Pumps incorporate a 20 cu. in. air motor design.
17. Optional Hoses Available(See Price List):  
ATD5362 10ft High Pressure Grease Hose  
ATD5363 20ft High Pressure Grease Hose  
ATD5364 30ft High Pressure Grease Hose  
ATD5365 40ft High Pressure Grease Hose  
ATD5366 50ft High Pressure Grease Hose  
Output: 80 cu in/minute of Grease at 100PSI NLGI#2 at 70 Degrees ambient temperature (.35 cu in/cycle)  
Air Inlet 1/8" NPT (f); Lube Outlet: 1/4" NPT (f)
20. Additional Accessories Available: ATD5356 Grease Strainer for Pump Tube;
21. Complete Repair Kit: ATD5320
22. Air Motor Repair Kit: ATD5322
23. Downtube Repair Kit: ATD5323

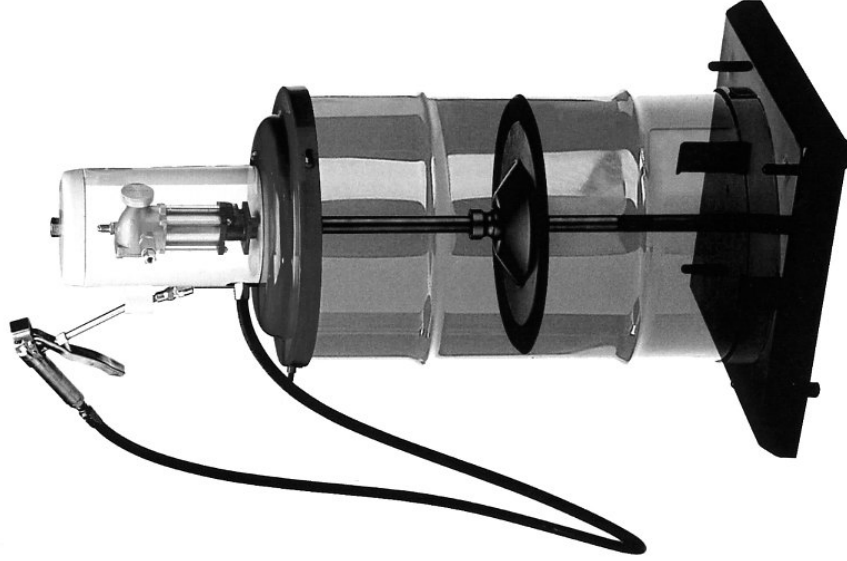

ATD Tools Inc.

# **TIPS SHEET FOR ATD GREASE PUMPS**

**#1: Unpacking the pump;** Be Careful where you lay the downtube. The slightest foreign material like a rock, grass, stone, metal or plastic will block the pump.

**#2: Lubricate the Air Motor** only with SAE 30 Common Motor Oil or NLGI #1 Grease.

**DO NOT USE ANY TYPE OF SYNTHETIC OIL IN THE AIR MOTOR CASING. THIS INCLUDES MARVEL MYSTERY OIL OR ANY SYNTHETIC OIL. NO!!!!!!**

**#3: Use an Air Regulator with Gauge:** Normal Operating Pressure on the pump is between 80-100 psi. This will deliver 4500 PSI TO 5000 PSI of Grease Pressure.

**#4: Warranty is NULL AND VOID if used without an Air Regulator and Guage.**

**#5: Water will Damage** and Corrode the inside of the pump; Use a Moisture Evacuation System on your Air line to keep water out of the pump.

**#6: Lubricate the Air Motor** of the Pump, Once per Week by injecting 2-5 FL OZ's of SAE 30 Common Motor Oil into the Air Motor Air Inlet.

**#7: The pump has been tested** and spec'd at the factory and was operated with NLGI #2 Grease under a Static Test and a Dynamic Test (Pressure Test) for Grease Pumps.

## PUMP DIAGNOSTIC FOR ATD GREASE PUMPS

**Note: All Grease Pumps are tested in NLGI#2 Chassis Grease at the factory.** They are statically tested so they have to pump a certain amount of grease for a stated period of time. They are also dynamically tested so they are required to hold grease pressure for an extended period of time and at a stated rate of air pressure usually 100 psi of Air Pressure yields a grease pressure rating of 5000 PSI. Therefore problems of a new pump not working out of the box should be rare to none. However, problems can occur when unpacking and using your new grease pump for the first time. Please always read and follow directions in the Instruction Manual. Below are some minor trouble shooting tips to get you on your way, should you incur a problem. There is a more extensive trouble shooting manual in your instruction booklet and we request that you consult that for more information.

### **1: PUMP DOES NOT WORK OUT OF THE BOX:**

#### **Check List:**

- 1: Is your Air Line live – Operating?
- 2: Is there Air connected to the Pump.
- 3: Check the Air Nipple 11660ME: Is it drilled all the way through? If you hold the air nipple up can you see light through the other end? (not a common problem)
- 4: Is the Air Nipple threaded in the correct Hole which is the Air inlet on the Air Motor NPT 1/8";
- 5: The other threaded holes are the Muffler 3/8" NPT and the Grease Outlet 1/4" NPT. See Drawing in the Instruction Manual.

### **3: Is the Air Motor Hissing Air out of any of the seals on the Air Motor:**

- 1: This is not a common Problem.
- 2: It can be fixed by tightening the bolts on the Air Motor for the Seals in Question. This would be very rare and should not need to be done.

### **4: Pump is new out of the box; Air Motor Operates but no grease is coming out:**

- 1: Did you remove the plastic tube off of the bottom of the pump?
- 2: Did you accidentally lay the pump down in any foreign material such as metal pieces, rocks, dirt, paper, plastic, saw dust or shavings?
- 3: The slightest piece of foreign material will block the downtube of the pump. Consult the manual that accompanied the pump for an appropriate fix.

### **6: Air Motor is still operating but no grease is coming out.**

- 1: Does the container have plastic bag that holds the grease.
- 2: If so, try raising the pump ever so slightly and make sure the pump does not push up against the bottom of the container.
- 3: Sometimes that downtube when sitting on top of the plastic bag will try to suck up the plastic and the plastic will block the downtube.

### **8: Pump was operating fine; we changed the container of grease and now it will not pump grease:**

- 1: Did you change the container? How did you set the pump down when you changed the vat? A small amount of foreign material can block the inlet of the pump
- 2: Reset the follower plate in the new vat of grease to expel air pockets.
- 3: Try resetting the pump.
- 4: Disconnect the lube and operate the pump. If it pumps grease, the control valve is clogged.

### **2: So you have Air on the Pump and it does not work?**

What is the Pump Doing? Hissing air out of the Air Motor?:

- 1: This is not common but it does occur.
- 2: If it is hissing out of the Muffler, the air valve or slide valve is stuck in the neutral position.
- 3: Increase the Air Pressure to 100 PSI. Sometimes increasing the air pressure will throw the valve up or down and start the pump cycling.
- 4: If the pump has not been inserted in the grease, hold it upside down and tap it slightly – lightly on the cement floor. Please read the word **lightly**.
- 5: If the pump has been inserted in grease, use a rubber mallet and tap the pump slightly on the air motor head. Do not beat the muffler. Use only a rubber mallet not a hammer. The air motor head is a casting and it will crack.

### **5: Pump is new out of the box; Air Motor Operates but no grease is coming out:**

- 1: Disconnect the lube hose from the pump.
- 2: Seat the Follower plate; Sometimes the follower plate catches an air pocket underneath it. Pull out the pump and firmly push down on the follower plate to push out any air pockets.
- 3: Reseat the pump by pulling the pump half way out of the container, turning it and putting it back in the container?
- 4: Turn Air on to the Pump and let the pump operate. These pumps are self priming will pick up grease and create a vacuum under the follower plate.
- 5: Pump about 1/2 cup of grease out of the pump. You should hear a popping noise as the air pockets are released from the grease.

### **7: Grease comes out of the pump outlet but not the control valve.**

- 1: The control valve is plugged. Whenever you change hoses or have a new hose you should always pump about 1/2 cup of grease through the hose to remove any contaminants inside the hose.
- 2: If control valve is plugged with a contaminant, you need to remove the debris from inside the control valve.

### **9: Pump was Operating fine; We did not change a vat of grease; The pump will not start;**

- 1: Check the Air Motor. Do you have water in your air line.
- 2: Try injecting 8-10 fl oz's of common SAE Motor oil into the Pump Inlet and let it sit.
- 3: **Do not use any type of Synthetic Oil or Air Tool Oil as this will ruin (swell) the Buna N Packings and render the pump useless.**

**REPAIR KIT LISTINGS FOR THE ATD-5217 AND ATD-5217-1**

| COMPLEX REPAIR KIT FOR AIR MOTOR AND DOWNTUBE<br>83054-ME<br>FOR MODELS ATD-5217-1, ATD-5289-1, ATD-5219-1 |       |                      |                                   |       |                         | SIMPLE REPAIR KIT FOR AIR MOTOR AND DOWNTUBE ATD-5320<br>FOR MODELS ATD-5217-1, ATD-5289-1, ATD-5219-1 |       |                      |                                   |       |                         |
|--|-------|----------------------|-----------------------------------|-------|-------------------------|--|-------|----------------------|-----------------------------------|-------|-------------------------|
| QTY  | MODEL | DESCRIPTION          | QTY                               | MODEL | DESCRIPTION             | QTY  | MODEL | DESCRIPTION          | QTY                               | MODEL | DESCRIPTION             |
| 1  | 11340 | AIR MOTOR PISTON ROD | 1                                 | 33039 | PACKING NUT GASKET      | 1  | 11340 | AIR MOTOR PISTON ROD | 1                                 | 34206 | O RING                  |
| 1  | 11472 | TRIP PIN             | 1                                 | 34090 | AIR PISTON PACKING      | 1  | 11472 | TRIP PIN             | 1                                 | 34158 | COVER GASKET            |
| 1  | 11475 | TRIP SHOE            | 1                                 | 34206 | O RING                  | 1  | 11702 | CHECK WASHER         | 1                                 | 34180 | GLAND PACKING           |
| 1  | 11702 | CHECK WASHER         | 1                                 | 34158 | COVER GASKET            | 1  | 11721 | PRIMING CHECK        | 2                                 | 34368 | O RING                  |
| 1  | 11721 | PRIMING CHECK        | 1                                 | 34180 | GLAND PACKING           | 1  | 11723 | PLUNGER ROD          | 1                                 | 35073 | PRIMING CHECK PACKING   |
| 1  | 11723 | PLUNGER ROD          | 2                                 | 34368 | O RING                  | 1  | 11724 | PRIMING PLUNGER      | 3                                 | 35077 | GLAND PACKINGS OLD VER  |
| 1  | 11724 | PRIMING PLUNGER      | 1                                 | 35073 | PRIMING CHECK PACKING   | 1  | 11725 | PRIMING CHECK SEAT   | 1                                 | 35083 | TRIP ROD PACKING        |
| 1  | 11725 | PRIMING CHECK SEAT   | 3                                 | 35077 | GLAND PACKING OLD VER   | 1  | 11726 | CHECK SEAT           | 1                                 | 38162 | VALVE SEAT GASKET       |
| 1  | 11726 | CHECK SEAT           | 1                                 | 35083 | TRIP ROD PACKING        | 1  | 30003 | PACKING NUT GASKET   | 1                                 | 55137 | TRIP ROD PACKING SPRING |
| 1  | 30003 | PACKING NUT GASKET   | 1                                 | 38162 | VALVE SEAT GASKET       | 1  | 30011 | VALVE CAP GASKET     | 2                                 | 56038 | SPRING                  |
| 1  | 30011 | VALVE CAP GASKET     | 1                                 | 55137 | TRIP ROD PACKING SPRING | 1  | 31047 | CHECK SEAT GASKET    | 4                                 | 66010 | EQUALIZER BALL          |
| 1  | 31047 | CHECK SEAT GASKET    | 2                                 | 56038 | SPRING                  | 1  | 31048 | CONNECTOR GASKET     | 4                                 | 66213 | LOCK WASHER             |
| 1  | 31048 | CONNECTOR GASKET     | 1                                 | 61041 | AIR CYLINDER            | 1  | 31050 | GLAND GASKET         | <b>NEW VERSION GLAND PACKINGS</b> |       |                         |
| 2  | 31049 | BUSHING GASKET       | 4                                 | 66010 | EQUALIZER BALL          | 1  | 31054 | PUMP TUBE GASKET     | 1                                 | 34572 | O RING GLAND PACKINGS   |
| 1  | 31050 | GLAND GASKET         | 4                                 | 66213 | LOCK WASHER             | 2  | 33014 | AIR CYLINDER GASKET  | 1                                 | 38165 | U CUP GLAND PACKINGS    |
| 1  | 31054 | PUMP TUBE GASKET     | <b>NEW VERSION GLAND PACKINGS</b> |       |                         | 1  | 33039 | PACKING NUT GASKET   |                                   |       |                         |
| 2  | 33014 | AIR CYLINDER GASKET  | 1                                 | 34572 | O RING GLAND PACKINGS   |  |       |                      |                                   |       |                         |
|  |       |                      | 1                                 | 38165 | U CUP GLAND PACKINGS    |  |       |                      |                                   |       |                         |

| DOWNTUBE REPAIR KIT ATD-5323<br>FOR MODELS ATD-5217-1, ATD-5289-1, ATD-5219-1 |       |                       |     |       |             | AIR MOTOR REPAIR KIT ATD-5322<br>FOR MODELS ATD-5217-1, ATD-5289-1, ATD-5219-1 |       |                      |                                   |       |                         |
|---|-------|-----------------------|-----|-------|-------------|--|-------|----------------------|-----------------------------------|-------|-------------------------|
| QTY   | MODEL | DESCRIPTION           | QTY | MODEL | DESCRIPTION | QTY  | MODEL | DESCRIPTION          | QTY                               | MODEL | DESCRIPTION             |
| 1   | 11702 | CHECK WASHER          |     |       |             | 1  | 11340 | AIR MOTOR PISTON ROD | 1                                 | 34180 | GLAND PACKING           |
| 1   | 11721 | PRIMING CHECK         |     |       |             | 1  | 11472 | TRIP PIN             | 2                                 | 34368 | O RING                  |
| 1   | 11723 | PLUNGER ROD           |     |       |             | 1  | 11475 | TRIP SHOE            | 3                                 | 35077 | GLAND PACKING OLD VER   |
| 1   | 11724 | PRIMING PLUNGER       |     |       |             | 1  | 30003 | PACKING NUT GASKET   | 1                                 | 35083 | TRIP ROD PACKING        |
| 1   | 11725 | PRIMING CHECK SEAT    |     |       |             | 1  | 30011 | VALVE CAP GASKET     | 1                                 | 38162 | VALVE SEAT GASKET       |
| 1   | 11726 | CHECK SEAT            |     |       |             | 1  | 31048 | CONNECTOR GASKET     | 1                                 | 55137 | TRIP ROD PACKING SPRING |
| 1   | 31047 | CHECK SEAT GASKET     |     |       |             | 1  | 31050 | GLAND GASKET         | 2                                 | 56038 | SPRING                  |
| 2   | 31049 | BUSHING GASKET        |     |       |             | 1  | 31054 | PUMP TUBE GASKET     | 1                                 | 61041 | AIR CYLINDER            |
| 1   | 35073 | PRIMING CHECK PACKING |     |       |             | 2  | 33014 | AIR CYLINDER GASKET  | 2                                 | 66010 | EQUALIZER BALL          |
| 2   | 66010 | EQUALIZER BALL        |     |       |             | 1  | 33039 | PACKING NUT GASKET   | 4                                 | 66213 | LOCK WASHER             |
|   |       |                       |     |       |             | 1  | 34090 | AIR PISTON PACKING   | <b>NEW VERSION GLAND PACKINGS</b> |       |                         |
|   |       |                       |     |       |             | 1  | 34206 | O RING               | 1                                 | 34572 | O-RING GLAND PACKING    |
|   |       |                       |     |       |             | 1  | 34158 | COVER GASKET         | 1                                 | 38165 | U CUP GLAND PACKINGS    |