



ATD-3451, ATD-3453, ATD-3456 INSTRUCTIONS FOR VACUUM PUMPS

Each vacuum pump has been factory tested for CFM and micron performance. The serial number has been recorded. Complete and mail the warranty form immediately to validate your warranty.

Retain shipping box and packing material for use if factory warranty service is required.

OPERATING INSTRUCTIONS

1. OIL FILL

This vacuum pump has been tested at the factory and shipped with only trace amounts of oil. **OIL MUST BE ADDED BEFORE OPERATING!** Failure to add oil will damage cartridge and void warranty!

- Make sure the oil drain plug located at the bottom of the front casing is closed before attempting to add oil.
- Remove the large oil fill plug from the top of pump and insert the oil bottle into the fill port.
- Slowly add oil until oil level rises to the Oil "FULL" Line. Do not overfill with oil!
- Replace the oil fill plug.

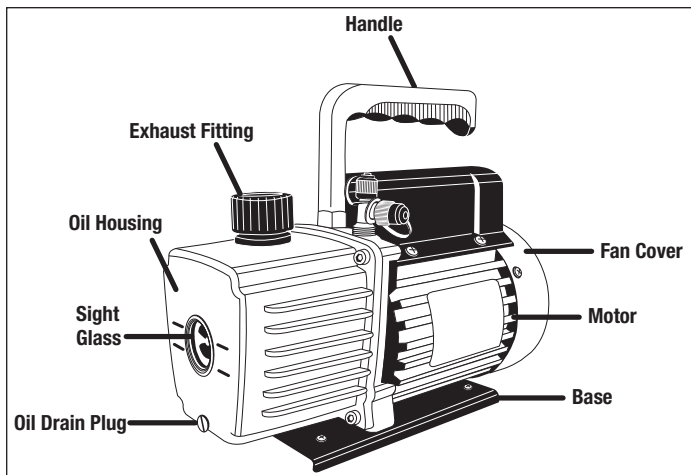

CAPACITY: 1.8 CFM = 8 oz.

CAPACITY: 3 CFM = 8 oz.

CAPACITY: 5 CFM = 12 oz.

2. CHECKING OIL LEVEL

- Start pump and run with intake port capped for about two minutes. Observe the oil level with the pump running. The oil level in the sight glass should be even with the level line.
- If the level is low, open the intake port and run pump for 15 seconds, stop pump and observe oil level again. Add a small amount of oil as needed.

3. CHANGING OIL

In order to reach the deep vacuum required, your vacuum pump needs clean, moisture-free oil during evacuation. Dirty oil becomes a mixture of corrosive acids and water that effects the pump's ability to pull a deep vacuum. Left sitting in the pump, this sludge will rust and erode internal surfaces...shortening the pump's life.

- Care should be taken to avoid contact of oil with skin or eyes.
 - OIL MAY BE HOT!
 - Used oil should be properly disposed of in a leakproof corrosive-resistant container according to local regulations.
- After every evacuation, while the pump is warm and oil is thin, take a small sample of oil from the drain port.
 - If the oil is contaminated, drain the oil by placing the pump on a level surface and opening the



WARNING!



WEAR SAFETY GLASSES

- oil drain valve. Catch the waste oil in a container and properly dispose of it.
- c. If the pump has been sitting for more than one month, the oil is considered contaminated regardless of appearance and should be changed as outlined above.
- d. To add oil, close drain, remove the oil fill cap and fill to the Oil Level Line with fresh oil.

4. INTAKE CONNECTIONS

Replace all caps and finger-tighten. Do not use caps with damaged or missing O-rings and always store vacuum pump with capped ports to prevent dirt and moisture contamination.

5. PUMP MOTOR

The **PUMP** and **OIL** must be above 30°F.

The line voltage must be equal to the rating on the motor nameplate $\pm 10\%$. Normal operating temperature is approximately 160°F, which is **HOT** to the touch! Line voltage and ambient temperature will affect the normal operating temperature somewhat. Your vacuum pump is designed for continuous duty and will run for extended periods without overheating.

The motor has an automatic resetting overload protection feature. If the motor will not restart the pump after shut-off, it may have opened the thermal protection. Disconnect the pump from the system, wait about 15 minutes for the motor to cool down and then try again.

ATD-3451, ATD-3453, ATD-3456 PARTS BREAKDOWN

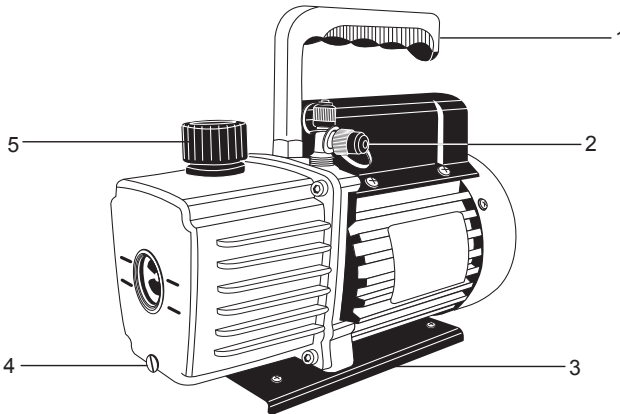

REF. #	DESCRIPTION	PART #
1.	HANDLE	290066-H
2.	T FITTING WITH CAPS	290052-31
3.	BASE PLATE	2900066-BASE
4.	OIL DRAIN PLUG	290059-28
5.	EXHAUST FITTING	290066-10