



ATD-2139

UTILITY CUT-OFF TOOL WITH GUARD

! WARNING

- **MAXIMUM RPM OF 22,000**
- **ALWAYS WEAR APPROVED EAR AND EYE PROTECTION.**
- **ALWAYS OPERATE AT MAX. AIR PRESSURE OF 90 PSIG, 6.2 BAR.**
- **REPETITIVE MOTION/EXTENDED EXPOSURE TO VIBRATION MAY HARM HANDS/ARMS.**
- **ACCESSORY USED MUST BE RATED HIGHER THAN 22,000 RPM**
- **USE RECOMMENDED GUARD**

! WARNING



ALWAYS READ INSTRUCTIONS BEFORE USING POWER TOOLS

THIS INSTRUCTION MANUAL CONTAINS IMPORTANT SAFETY INFORMATION

READ CAREFULLY AND UNDERSTAND ALL INFORMATION BEFORE OPERATING THIS TOOL!

SAVE THIS MANUAL FOR FUTURE REFERENCE.

! WARNING

Some dust created by power sanding, sawing, grinding, drilling, and other construction activities contains chemicals known to cause cancer, birth defects or other reproductive harm. Some examples of these chemicals are:

- lead from lead-based paints,
- crystalline silica from bricks and cement and other masonry products, and
- arsenic and chromium from chemically-treated lumber.

Your risk from these exposures varies, depending on how often you do this type of work. To reduce your exposure to these chemicals: work in a well ventilated area, and work with approved safety equipment, such as those dust masks that are specially designed to filter out microscopic particles.

S P E C I F I C A T I O N S



| | |
|--------------------------------|--------------------|
| Free Speed | 22,000 RPM |
| Air Inlet | 1/4"-18 NPT |
| Hose Size | 3/8" I.D. |
| Rec. Air Pressure | .90 psig (6.2 bar) |
| Avg. Air Consumption | 3.92 cfm |
| Sound Level | 100 dBA |
| Length | .7.5" |
| Shipping Weight | 2.8 Lbs. |



⚠ WARNING!

FAILURE TO OBSERVE THESE WARNINGS COULD RESULT IN INJURY.

THIS INSTRUCTION MANUAL CONTAINS IMPORTANT SAFETY INFORMATION.

READ THIS INSTRUCTION MANUAL CAREFULLY AND UNDERSTAND ALL INFORMATION BEFORE OPERATING THIS TOOL.

- Always operate, inspect and maintain this tool in accordance with American National Standards Institute Safety Code of Portable Air Tools (ANSI B186.1) and any other applicable safety codes and regulations.
- For safety, top performance and maximum durability of parts, operate this tool at 90 psig 6.2 bar max air pressure with 3/8" diameter air supply hose.
- Always wear impact-resistant eye and face protection when operating or performing maintenance on this tool. Always wear hearing protection when using this tool. 
- High sound levels can cause permanent hearing loss. Use hearing protection as recommended by your employer or OSHA regulation.
- Keep the tool in efficient operating condition.
- Operators and maintenance personnel must be physically able to handle the bulk, weight and power of this tool.
- Air under pressure can cause severe injury. Never direct air at yourself or others. Always turn off the air supply, drain hose of air pressure and detach tool from air supply before installing, removing or adjusting any accessory on this tool, or before performing any maintenance on this tool. Failure to do so could result in injury. Whip hoses can cause serious injury. Always check for damaged, frayed or loose hoses and fittings, and replace immediately. Do not use quick detach couplings at tool. See instructions for correct set-up. 
- Air powered tools can vibrate in use. Vibration, repetitive motions or uncomfortable positions over extended periods of time may be harmful to your hands and arms. Discontinue use of tool if discomfort, tingling feeling or pain occurs. Seek medical advice before resuming use.

- Place the tool on the work before starting the tool. Do not point or indulge in any horseplay with this tool.
- Slipping, tripping and/or falling while operating air tools can be a major cause of serious injury or death. Be aware of excess hose left on the walking or work surface. 
- Keep body working stance balanced and firm. Do not overreach when operating the tool.
- Anticipate and be alert for sudden changes in motion during start up and operation of any power tool.
- Do not carry tool by the hose. Protect the hose from sharp objects and heat.
- Tool shaft may continue to rotate briefly after throttle is released. Avoid direct contact with accessories during and after use. Gloves will reduce the risk of cuts or burns.
- Keep away from rotating end of tool. Do not wear jewelry or loose clothing. Secure long hair. Scalping can occur if hair is not kept away from tool and accessories. Choking can occur if neckwear is not kept away from tool and accessories. 
- Do not lubricate tools with flammable or volatile liquids such as kerosene, diesel or jet fuel.
- Don't force tool beyond its rated capacity.
- Do not remove any labels. Replace any damaged labels.
- Accessory retainers should be used to prevent discharge or ejection of the accessory which might cause injury.
- Use accessories recommended by ATD Tools.

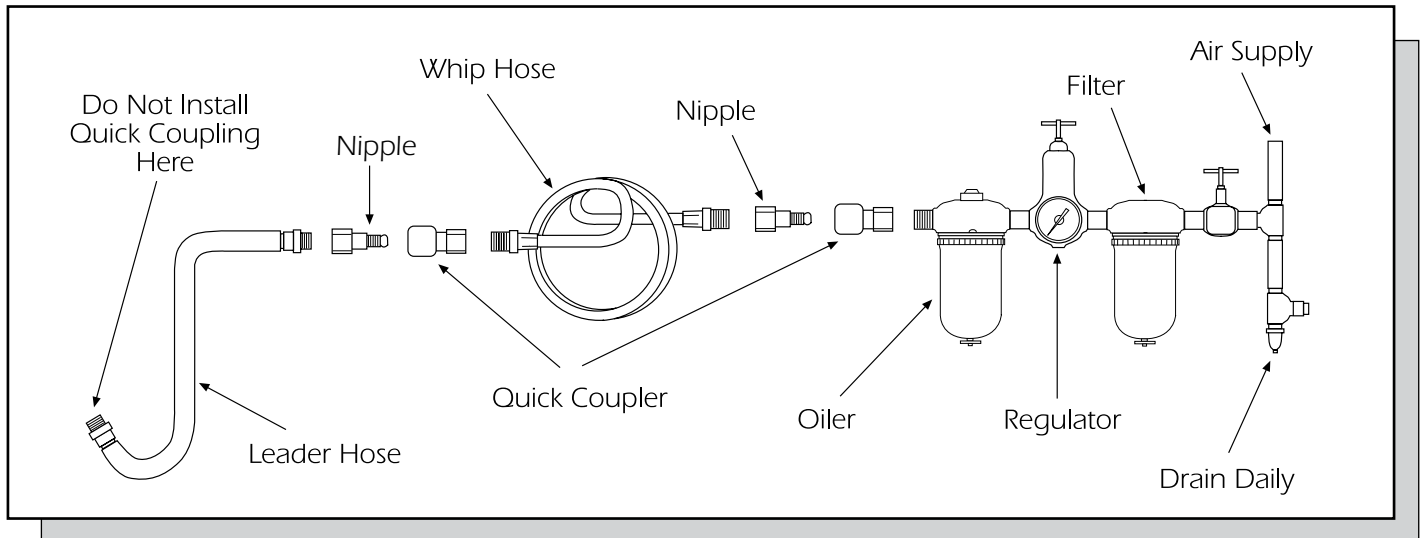

Air Supply...

Tools of this class operate on a wide range of air pressures. It is recommended that air pressure of these tools measures 90 PSI at the tool while running free. Higher pressure (over 90 psig; 6.2 bar) raises performance beyond the rated capacity of the tool which will shorten the tool's life because of faster wear and could cause injury.

Always use clean, dry air. Dust, corrosive fumes and/or water in the air line will cause damage to the tool. Drain the air tank daily. Clean the air inlet filter screen on at least a weekly schedule. The recommended hookup procedure can be viewed in the above figure.

The air inlet used for connecting air supply, has standard 1/4" NPT. Line pressure should be increased to compensate for unusually long air hoses (over 25 feet). Minimum hose diameter should be 3/8" I.D. and fittings should have the same inside dimensions and be tightly secured.

Operating Instructions...

Let the tool do the work. Do not put extreme pressure on the machine. This will only slow down the speed of the cutting wheel, reduce cutting efficiency, and put an additional burden on the motor. Start the tool off the work, set it down on the work evenly and move in the direction desired to make the cut. When finished cutting, lift off the work before stopping the motor.

NOTE: DURING OPERATION SAFETY GOGGLES SHOULD ALWAYS BE WORN TO GUARD AGAINST FLYING RUSH AND CHIPS.

USE ONLY WHEELS RATED AT 22,000 RPM OR HIGHER.

Lubrication & Maintenance...

Lubricate the air motor daily with quality air tool oil. If no air line oiler is used, run 1/2 oz. of oil through the tool. The oil can be squirted into the tool air inlet or into the hose at the nearest connection to the air supply, then run the tool. Overfilling will cause a reduction in the power of the tool.

WARNING: After an air tool has been lubricated, oil will discharge through the exhaust port during the first few seconds of operation. The exhaust port must be covered with a towel before applying air pressure to prevent serious injury.

Warranty...

ATD Tools warrants its air tools for a period of 1 year to the consumer. We will repair any air tool covered under this warranty which proves to be defective in material or workmanship during the warranty period. In order to have your tool repaired, return the tool to any authorized ATD Warranty Center, freight prepaid. Please include a copy of your proof of purchase and a brief description of the problem. The tool will be inspected and if any part or parts are found to be defective in material or workmanship, they will be repaired free of charge and the repaired tool will be returned to you freight prepaid.

This warranty gives you specific rights. You may also have other rights which vary from state to state. The foregoing obligation is ATD Tools' sole liability under this or any implied warranty and under no circumstances shall ATD Tools be liable for any incidental or consequential damages.

Note: Some states do not allow the exclusion or limitation of incidental or consequential damages so the above limitation or exclusion may not apply to you.

ATD-2139

Utility Cut-Off Tool with Guard

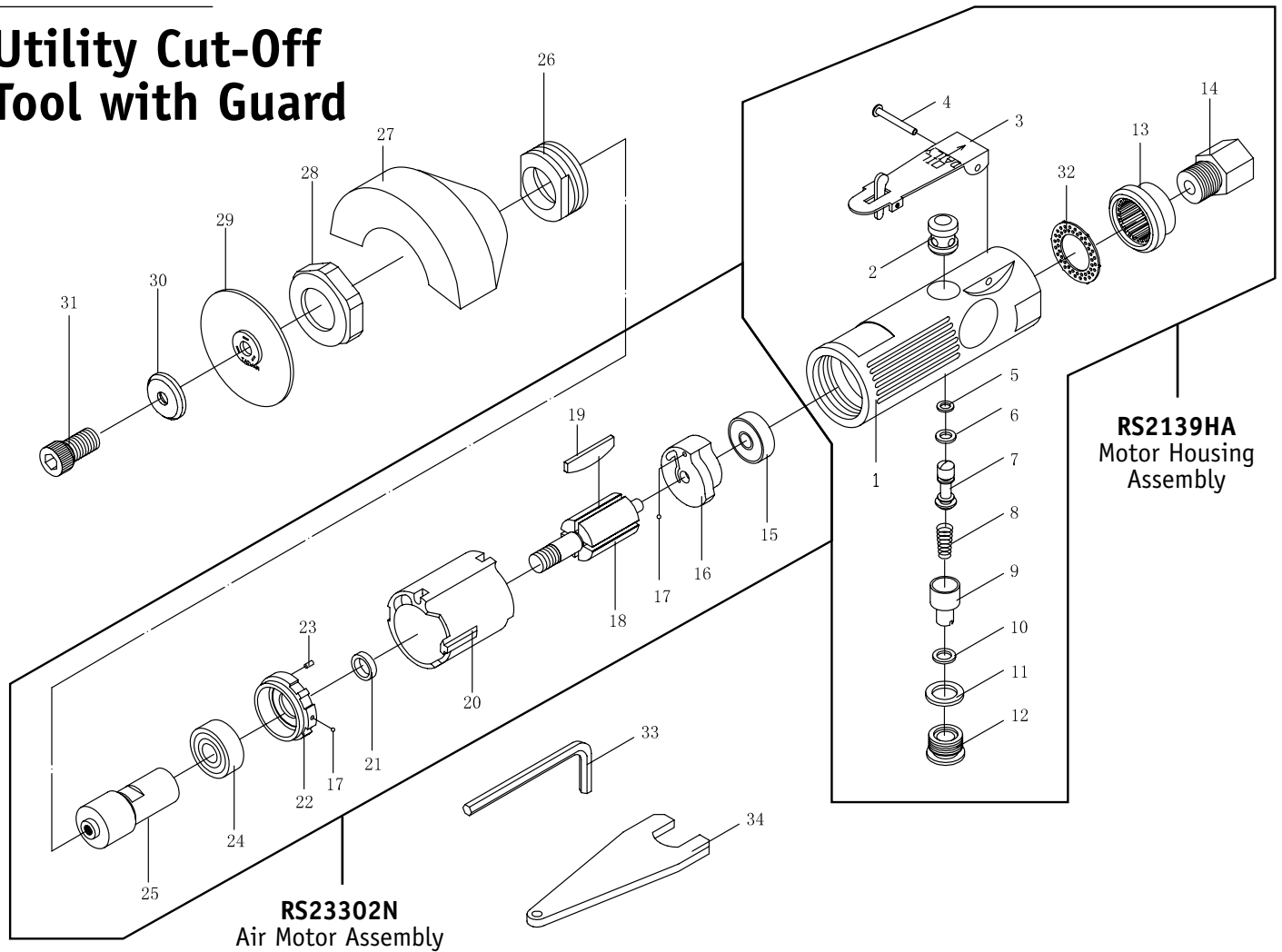

| Ref. No. | Part No. | Description | Qty. |
|----------|----------|--------------------|------|
| 1 | * | Housing | 1 |
| 2 | * | Valve Bushing | 1 |
| 3 | * | Throttle Lever | 1 |
| 4 | * | Throttle Lever Pin | 1 |
| 5 | * | O-Ring | 1 |
| 6 | * | O-Ring | 1 |
| 7 | * | Valve Stem | 1 |
| 8 | * | Spring | 1 |
| 9 | * | Air Regulator | 1 |
| 10 | * | O-Ring | 1 |
| 11 | * | O-Ring | 1 |
| 12 | * | Valve Plug | 1 |
| 13 | * | Muffler Cover | 1 |
| 14 | * | Air Inlet Bushing | 1 |
| 15 | ** | Ball Bearing | 1 |
| 16 | ** | Rear End Plate | 1 |
| 17 | ** | Steel Ball | 2 |

| Ref. No. | Part No. | Description | Qty. |
|----------|-----------|-----------------------|------|
| 18 | ** | Rotor | 1 |
| 19 | ** | Rotor Blade | 4 |
| 20 | ** | Cylinder | 1 |
| 21 | ** | Bushing | 1 |
| 22 | ** | Front End Plate | 1 |
| 23 | ** | Pin | 1 |
| 24 | ** | Ball Bearing | 1 |
| 25 | ** | Grinder Wheel Spindle | 1 |
| 26 | RS820DG33 | Retainer | 1 |
| 27 | RS23330A | Guard | 1 |
| 28 | RS820DG35 | Nut | 1 |
| 29 | | Cutting Wheel | 1 |
| 30 | RS820DG37 | Washer | 1 |
| 31 | RS820DG38 | Bolt | 1 |
| 32 | * | Muffler Slice | 1 |
| 33 | RS820DG40 | Hex Key | 1 |
| 34 | RS820DG11 | Wrench | 1 |

NOTE: Only reference numbers identified by part numbers are available.

* Available only as RS2139HA Housing Assembly (incl. #1-14, 32)

** Available only as RS23302N Air Motor Assembly (incl. #15-25)