



PROFESSIONAL
QUALITY
FASTENERS

INSTALLATION METHOD FOR SUBARU MAIN BOLT KITS

Part Number: 260-5401 Application: EJ Series 4-Cylinder

Note: When changing from factory fasteners to high strength fasteners, clamping force and tolerances will change. Therefore it will be necessary to have the main bore checked for size and straightness and align honed if necessary after installation of this product.

1. To ensure proper thread engagement and accurate torque readings, clean ALL threads in the block. Chase if necessary with ARP Thread Chaser(s), part numbers 912-0002 (10mm) and 912-0001 (8mm).
2. Clean and inspect all hardware prior to installation. Look for obvious defects or shipping damages, plus proper fit, length and dimension. **Warning: DO NOT remove the sealing washers from the 10mm bolts on which they were installed. These six bolts have special diameter shanks that locate the sealing washers as well as help aid in the sealing of the coolant passage. Failure to heed this warning will result in internal coolant leakage past the bolt head.**
3. Set aside the six 10mm bolts with sealing washers, then install the stainless washers supplied in the kit on the remaining ten bolts as follows:
 - A. Install **four 10mm chamfered washers** (catalog part no. 400-8519) with the chamfer towards the underhead of the bolt on the **four 10 mm bolts without sealing washers** (two long, two short).
 - B. Install the **8mm stainless washers on the remaining 8mm bolts.**
4. Lubricate the bolt threads with ARP Ultra-Torque Fastener Assembly Lubricant. **ARP recommends using the ARP Ultra-Torque Fastener Assembly Lubricant as opposed to motor oil. This is due to higher friction on the bolts as well as inconsistencies in the clamping force of the fasteners when motor oil (or low quality lubricant) is used.** Also apply ARP Ultra-Torque Fastener Assembly Lubricant between the bolt head and washer on each bolt.
5. Assemble the bare cylinder block halves together without the crankshaft and the main bearings according to OEM procedures. Check for binding or misalignment.
6. Install **four 10mm bolts with sealing washers into the right hand case on the #2 & #3 main journals.** Then install the remaining **two 10mm bolts with sealing washers into the left hand case on the #4 main journal.** Tighten the bolts hand tight (see illustration on the reverse side).
7. Install the **two short 10 mm bolts with chamfered washers into the left hand case on the #1 main journal.** Install the **two long 10 mm bolts with chamfered washers into the right hand case on the #5 main journal** and tighten the bolts hand tight.
8. Fit the remaining 8mm bolts with washers into the left hand case paying special attention to the location of the 8mm x 85 mm length bolt. Tighten the bolts hand tight.

PRELOAD (TORQUE) RECOMMENDATIONS:

9. Following the manufacturers recommended torque sequence (see illustrations on the reverse side) tighten the **10mm bolts in three equal steps to 60 ft-lbs with ARP Ultra-Torque Fastener Assembly Lubricant.**
10. Tighten the **8mm bolts in sequence to 25 ft-lbs with ARP Ultra-Torque Fastener Assembly Lubricant.**

Caution: Some customers may choose to install the bolts at the factory torque specifications without align honing the block but they will not receive the full benefits of ARP's high strength fasteners.

Note: Please contact your local Subaru dealer for replacement sealing washers-Subaru Part No. 11034-AA000

(Long) 10mm bolts with chamfered washers - 2qty
No. 5 main

Right hand case

Left hand case

8mm X .65mm bolts - 6qty

10mm bolts with sealing washers - 4qty
No.2 & 3 mains

8mm X .85mm bolt -1qty

(Short) 10mm bolts with chamfered washers - 2qty
No.1 main

10mm bolts with sealing washers - 2qty
No.4 main

Bolt Location Diagram

10mm Bolt Tightening Sequence

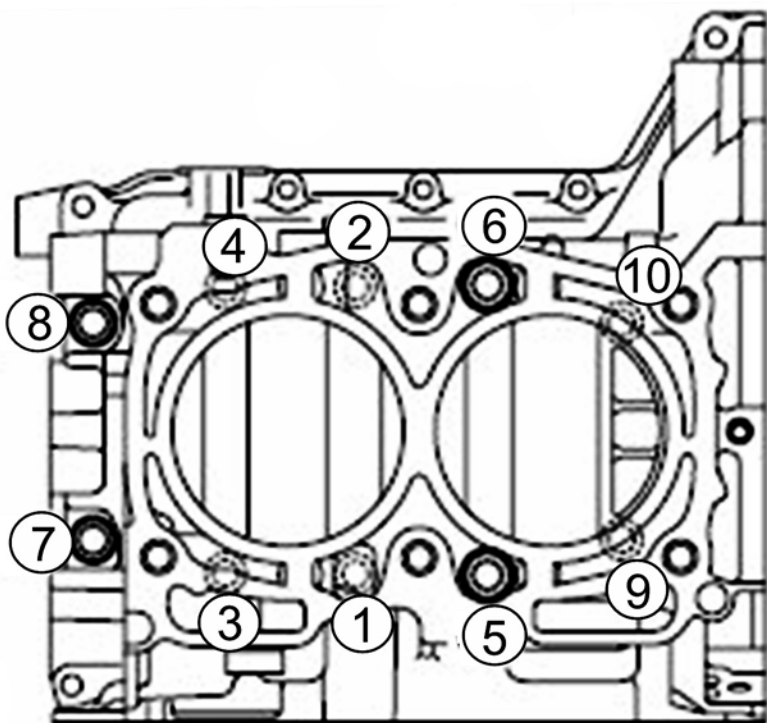

8mm Bolt Tightening Sequence

