



**ARMORDILLO Products are designed as decorative accessories and should not be relied upon as protection for the vehicle or passengers. Buyers assume all risk and liability whatsoever resulting from installation and use of products. We assume no liability for injury, loss, incidental or consequential damages in the event of an accident.**

**ARMORDILLO guarantees the original purchaser a LIMITED 3-YEAR WARRANTY from date of purchase against manufactured defects in materials, workmanship and finish under normal use. This excludes damage resulting from road hazards, debris, product misuse, improper installation, impairments from accidents, neglect, shipping or product modification. This warranty applies only to new products and is limited to the repair or replacement products. Warranty does not include cost of removal, installation, labor, freight, inconvenience, or consequential damage. Original purchaser must return defective merchandise to the original place of purchase and must provide the proof of purchase.**

**WARNING: When working on, under or around vehicle exercise caution. If working without a lift check vehicle owners manual for correct jacking points. Always wear safety glasses and ensure a safe working area. Serious injury or death could occur if safety measures are not followed.**

**ARMORDILLO RECOMMENDS PROFESSIONAL INSTALLATION ON ALL THEIR PRODUCTS STOP - Verify part and application is correct before proceeding. If missing part or damage item please contact customer service directly via message system on the site you bought the item from.**

**Call us at (909)895-4522 Monday-Friday 9am-6pm PST  
Email us At [SUPPORT@ARMORDILLOUSA.COM](mailto:SUPPORT@ARMORDILLOUSA.COM)**

**PARTS LIST:**

1	Driver/Left Mounting Bracket	4	10mm Lock Washers
1	Passenger/Right Mounting Bracket	4	10mm Hex Nuts
1	License Plate Bracket	4	8mm x 25mm Combo Bolts
4	12mm x 40mm Bolt Plates	2	6mm x 20mm Button Head Combo Bolts
4	12mm x 32mm OD x 3mm Flat Washers	2	6mm x 20mm Button Head Bolts
4	12mm Lock Washers	4	6mm x 18mm OD x 1.6mm Flat Washers
4	12mm Hex Nuts	2	6mm Lock Nuts
4	12mm Plastic Retainers	2	6mm Hex Nuts
2	10mm U-Bolts	1	4mm Hex Wrench
4	10mm x 30mm OD x 2.5mm Flat Washers		

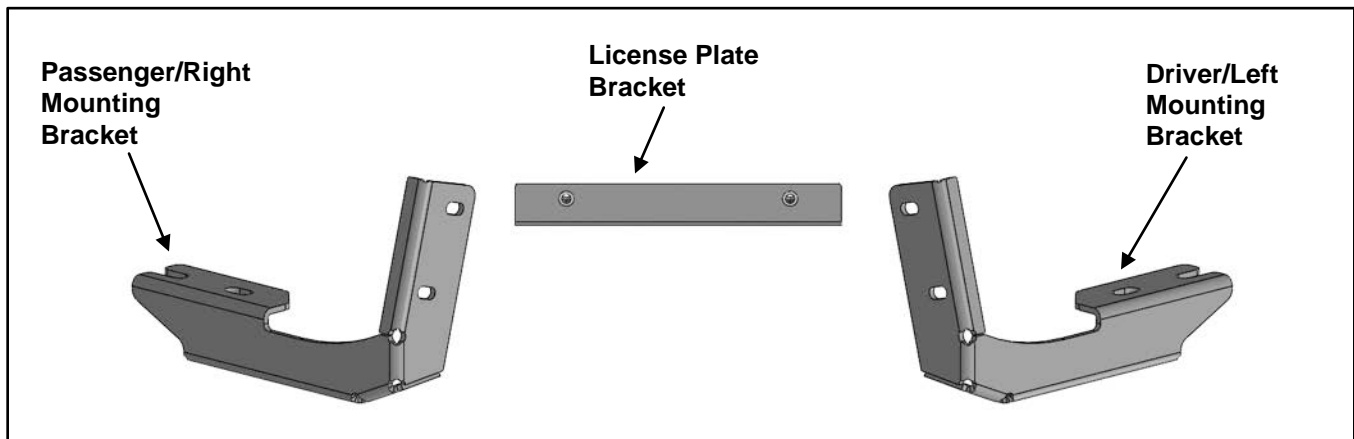

**PROCEDURE:**

1. **REMOVE CONTENTS FROM BOX. VERIFY ALL PARTS ARE PRESENT. READ INSTRUCTIONS CAREFULLY BEFORE STARTING INSTALLATION. CUTTING MAY BE REQUIRED. ASSISTANCE IS RECOMMENDED.**

2. Determine if the vehicle is equipped with tow hooks, **(Figure 1)**.

**Vehicles with Factory Tow Hooks**

- a. Remove each tow hook by removing the front bolt and only loosening the rear bolt, **(Figure 2)**. Slide the tow hook off. Keep the factory double nut plate in the frame and aligned with the holes. **NOTE:** Tow hooks cannot be reinstalled.
- b. Select the Driver/Left Mounting Bracket. Position the Bracket up to the bottom of the frame. Reuse the tow hook hardware to attach the Bracket to the bottom of the frame and factory double nut plate.
- c. Repeat to install the Passenger/Right Mounting Bracket.
- d. Skip to **Step 3**.

**All vehicles without Tow Hooks**

Remove the lower plastic portion of the bumper to gain access to the ends of the frame rails, **(Figure 3)**. The lower bumper or splash guard will need to be cut out to allow the Mounting Brackets and end of Bull Bar to pass through, **(see Step 5)**. On some models, access to the mounting hardware is limited. For 15-on model years with fog lights, bumper may need to be removed to remove splash guard. For access, first remove the plastic bumper pad from each side of the opening in the center of the bumper, **(Figure 4)**. Remove splash guard and temporarily reinstall bumper.

**Vehicles without Tow Hooks and open end of frame**

- a. Starting on the Driver/Left side of the vehicle, insert (2) 12mm Bolt Plates through the opening in the end of the frame and down through the holes in the bottom of the frame, **(Figures 5A & 5B)**. Thread (2) 12mm Plastic Retainers onto the threads of the Bolt Plates to hold them in place

- b. Attach the Driver/Left Mounting Bracket to the (2) Bolt Plates with (2) 12mm Flat Washers, (2) 12mm Lock Washers and (2) 12mm Hex Nuts, **(Figure 5C)**.
- c. Do not tighten the hardware.
- d. Repeat to install the Passenger/Right Mounting Bracket.

**Vehicles without Tow Hooks, closed end of frame**

- a. Starting on the Driver/Left side of the vehicle, locate the two holes on the bottom of the frame. Insert (1) 10mm U-Bolt into one hole and out the other, **(Figures 6A & 6B)**.
  - b. Attach the Driver/Left Mounting Bracket to the U-Bolt with (2) 10mm Flat Washers, (2) 10mm Lock Washers, and (2) 10mm Hex Nuts **(Figure 6C)**.
  - c. Do not fully tighten hardware.
  - d. Repeat to install the Passenger/Right Mounting Bracket.
- 3. With assistance, hold up the assembled Bull Bar to the Mounting Brackets. Attach the Bull Bar to the Brackets with (4) 8mm Combo Bolts, **(Figure 7)**.
  - 4. Select the License Plate Bracket. Attach the Bracket to the center of the Bull Bar with (2) 6mm Button Head Bolts, (4) 6mm Flat Washers, (2) 6mm Lock Washers and (2) 6mm Hex Nuts. Use Attach the license plate to the Bracket with (2) 6mm Button Head Combo Bolts, **(Figures 8 & 9)**.
  - 5. Level and adjust the Bull Bar properly and tighten all hardware.

**Models without openings in lower bumper or splash guard for tow hooks.** Hold the splash guard up to the bottom of the bumper and bull bar brackets. Trace the location of both Brackets onto the back of the cover. Temporarily remove the Bull Bar with Mounting Brackets only. Cut openings in the cover to clear the Frame Brackets and end of Bull Bar Brackets as necessary. For best results, start with a small slot and slowly enlarge the opening to clear the Brackets. Once cover is properly fit to the Brackets, remove bumper, reattach the splash guard to the bumper. Reinstall the bumper assembly and Bull Bar assembly as previously described.

- 6. Do periodic inspections to the installation to make sure that all hardware is secure and tight.

**To protect your investment,** Do not use any type of polish or wax that may contain abrasives that could damage the finish. Mild soap may be used to clean the Bull Bar.

**Driver Side Installation Pictured**

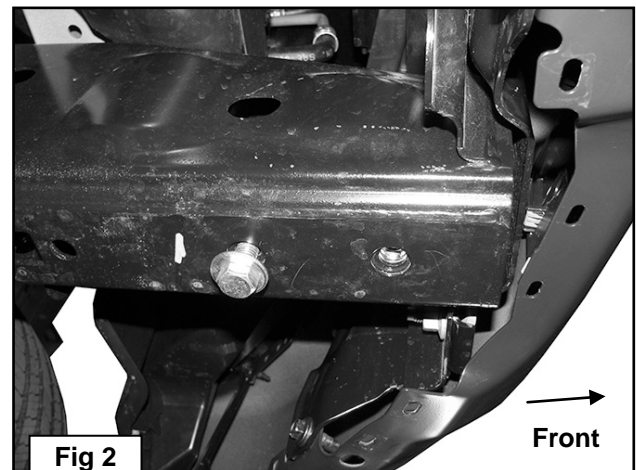
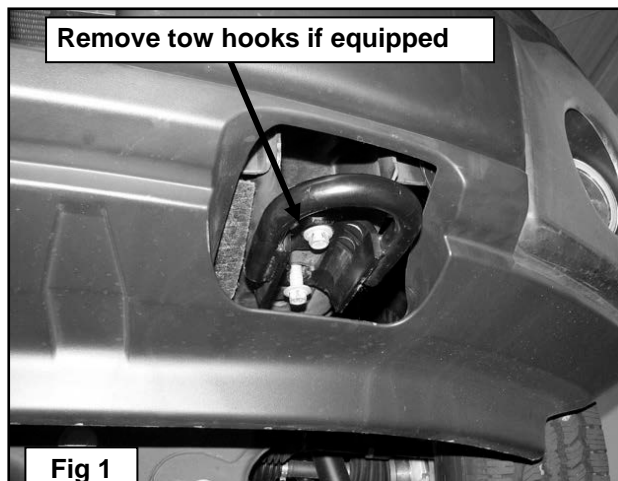

Driver Side Installation Pictured



(Fig 3) Models without tow hooks, temporarily remove the plastic splash guard and spoiler if equipped



(Fig 4) Remove bumper pads to access splash guard hardware if necessary. 2017 F150 pictured

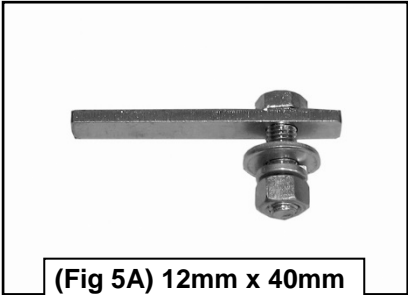

(Fig 5A) 12mm x 40mm Bolt Plates

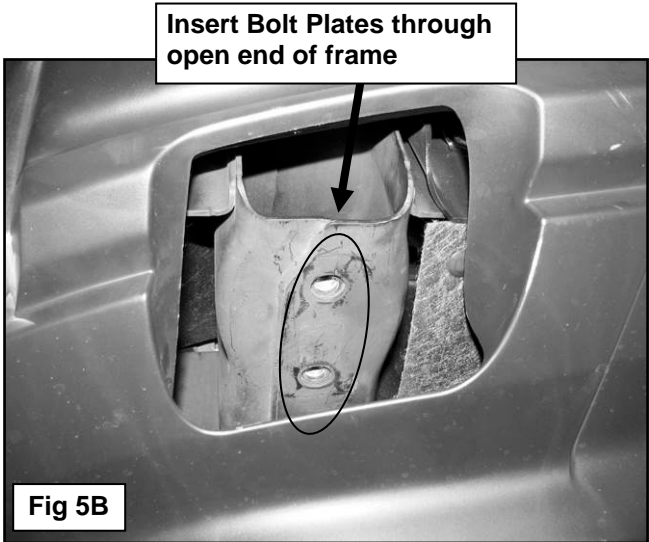

Insert Bolt Plates through open end of frame

Fig 5B

Driver Side Installation Pictured

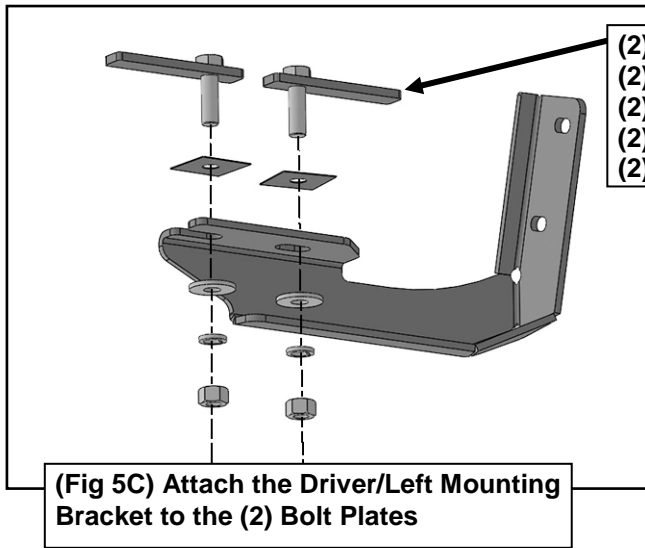

Insert 10mm U-Bolt into one hole and out the other. (U-Bolt is only used on vehicles with "closed end frames")

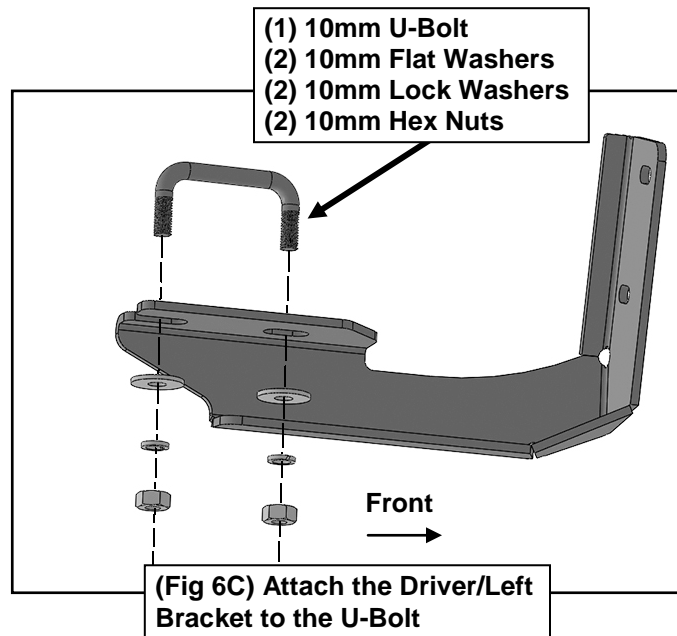
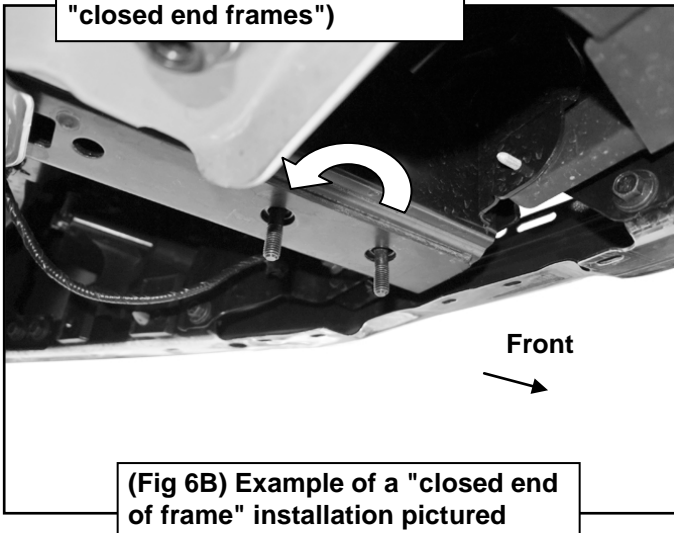

Driver Side Installation Pictured

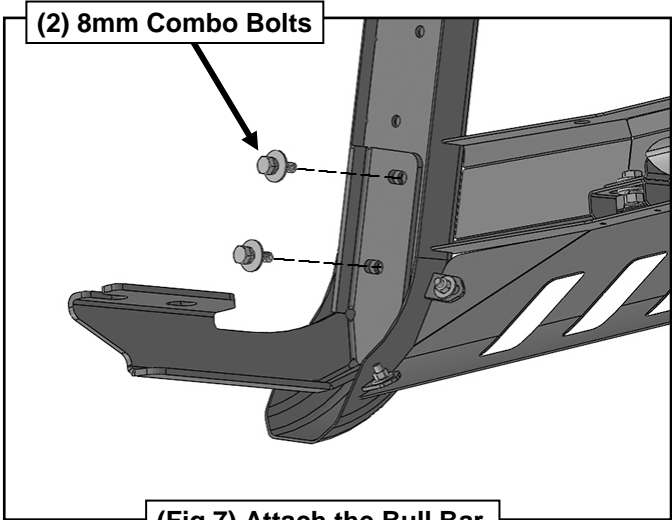

(Fig 7) Attach the Bull Bar to the Mounting Brackets

- (2) 6mm Button Head Bolts
- (4) 6mm Flat Washers
- (2) 6mm Lock Washers
- (2) 6mm Hex Nuts

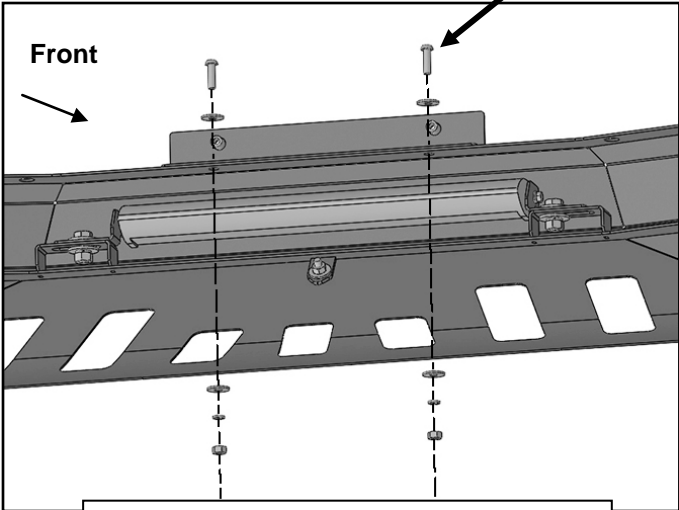

(Fig 8) Attach the License Plate Bracket to the center of the Bull Bar

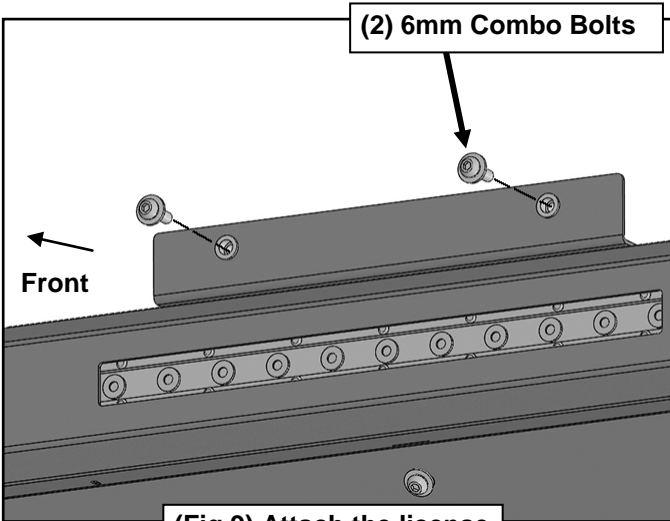

(Fig 9) Attach the license plate to the Bracket



ARMORDILLO Products are designed as decorative accessories and should not be relied upon as protection for the vehicle or passengers. Buyers assume all risk and liability whatsoever resulting from installation and use of products. We assume no liability for injury, loss, incidental or consequential damages in the event of an accident.

ARMORDILLO guarantees the original purchaser a LIMITED 3-YEAR WARRANTY from date of purchase against manufactured defects in materials, workmanship and finish under normal use. This excludes damage resulting from road hazards, debris, product misuse, improper installation, impairments from accidents, neglect, shipping or product modification. This warranty applies only to new products and is limited to the repair or replacement products. Warranty does not include cost of removal, installation, labor, freight, inconvenience, or consequential damage. Original purchaser must return defective merchandise to the original place of purchase and must provide the proof of purchase.

**WARNING:** When working on, under or around vehicle exercise caution. If working without a lift check vehicle owners manual for correct jacking points. Always wear safety glasses and ensure a safe working area. Serious injury or death could occur if safety measures are not followed.

ARMORDILLO RECOMMENDS PROFESSIONAL INSTALLATION ON ALL THEIR PRODUCTS STOP - Verify part and application is correct before proceeding. If missing part or damaged item please contact customer service directly via message system on the site you bought the item from.

**Call us at (909)895-4522 Monday-Friday 9am-6pm PST  
Email us At [SUPPORT@ARMORDILLOUSA.COM](mailto:SUPPORT@ARMORDILLOUSA.COM)**

**PARTS LIST:**

Models with sensors	
1	AVT Bull Bar
2	Plastic Sensor Covers
2	15.5mm x 25mm Foam Washers
2	20mm x 10mm Foam Spacers
2	Sensor Retaining Caps
4	4mm x 15mm Self Tapping Screws

Models without sensors	
1	AVT Bull Bar

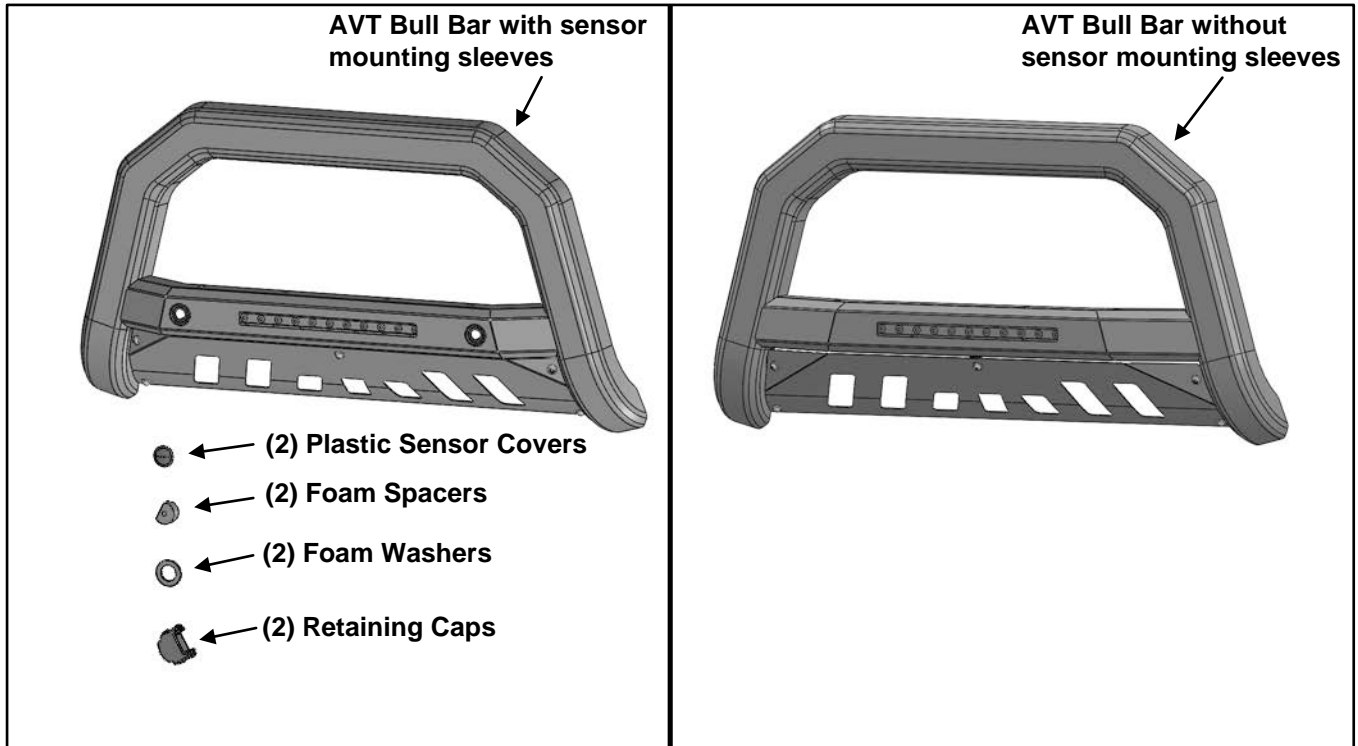

**PROCEDURE:**

**REMOVE CONTENTS FROM BOX. VERIFY ALL PARTS ARE PRESENT. READ INSTRUCTIONS CAREFULLY BEFORE STARTING INSTALLATION. ASSISTANCE IS RECOMMENDED.**

1. **For AVT Bull Bars without sensor mounting sleeves:**  
Continue to the Mounting Bracket kit instructions for attachment to the vehicle.
2. **For AVT Bull Bars with sensor mounting sleeves:**
  - a. Remove sensors and wiring harness from the back of the factory bumper, **(Figure 1)**.
  - b. **(OPTIONAL)** For vehicles that will run the wires under the bumper, select (1) Plastic Sensor Cap. Insert (1) Cap into (1) factory sensor sleeve, **(Figure 2)**. Repeat this **Step** to insert the remaining (1) Plastic Sensor Cap into the other sensor sleeve.
  - c. Select (1) sensor. Insert (1) 15.5mm Foam Washer, (1) factory sensor, (1) Foam Spacer and (1) Retaining Cap into the mounting sleeve in the back of the bumper, **(Figure 3)**.
  - d. **(OPTIONAL)** Secure sensor to the sleeve with (2) 4mm x 10mm Self Tapping Screws.  
**IMPORTANT:** Sensors fit snug in sleeves. The 4mm Screws are used to apply slight pressure to lock the sensors in place. Tighten both Screws evenly until they touch the sensor body only. Do not overtighten screws or damage to sensors will result.
  - e. Repeat previous **Steps** to install the remaining (1) sensors.
3. Do periodic inspections to the installation to make sure that all hardware is secure and tight.

**To protect your investment,** Do not use any type of polish or wax that may contain abrasives that could damage the finish. Mild soap may be used also to clean the Bull Bar.



Passenger/Right Side Installation Pictured

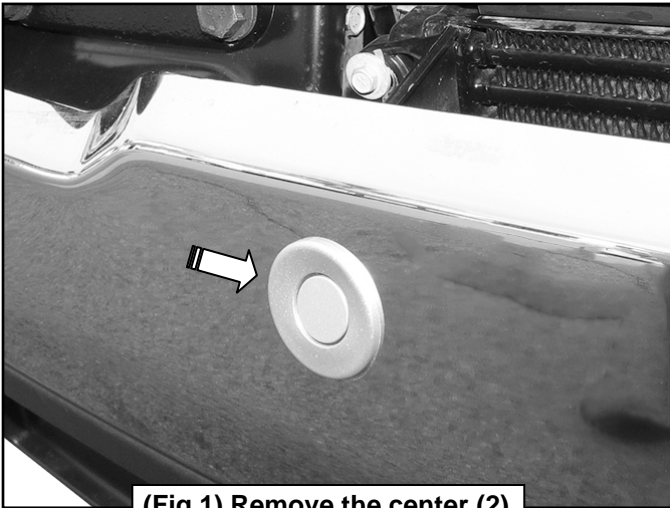

(Fig 1) Remove the center (2) sensors from the bumper



(Fig 2) (OPTIONAL) For models that will have the wires go under the bumper, insert (1) Plastic Sensor Cap into each of the (2) factory sensors sleeves

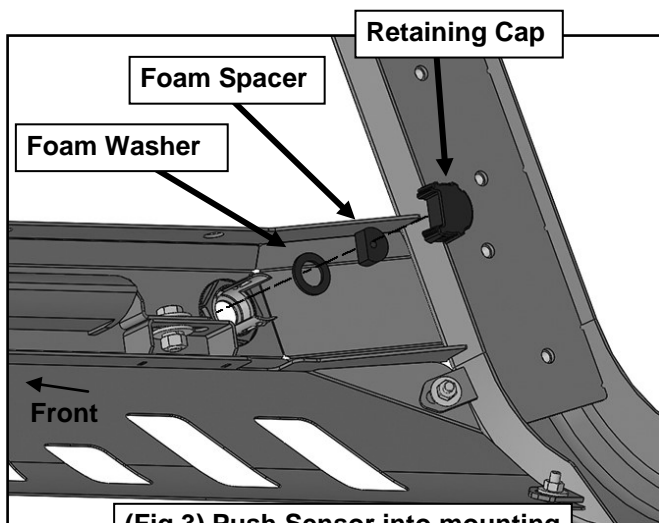

(Fig 3) Push Sensor into mounting sleeve (Optional, use 4mm Screws to lock sensor in place)