

# INSTALLATION INSTRUCTIONS

225016 / 225016-2

## 2009-10 DODGE RAM CREW CAB 1500

### PARTS LIST:

Qty	Description	Qty	Description
1	Driver/Left Side Bar	4	Plastic Square Retainer
1	Passenger/Right Side Bar	4	12mm x 120mm Hex Bolt
1	Driver/Left Front Mounting Bracket	4	12mm x 44 OD Flat Washer
1	Passenger/Right Front Mounting Bracket	4	12mm Lock Washer
1	Driver/Left Rear Mounting Bracket	12	10mm x 30mm OD Flat Washer
1	Passenger/ Rear Mounting Brace Bracket	12	10mm Lock Washer
1	Driver/Left Front Brace Bracket	4	10mm x 35mm Bolt Plate
1	Passenger/ Front Brace Bracket	8	10mm Hex Nut
1	Driver/Left Rear Brace Bracket	12	10mm x 30mm Hex Bolt
1	Passenger/ Rear Brace Bracket	8	10mm x 24 OD Flat Washer

Passenger/Right side Rear Mounting Bracket



Driver/Left side Rear Mounting Bracket



10mm x 35mm Bolt Plate (with Plastic retainer installed)

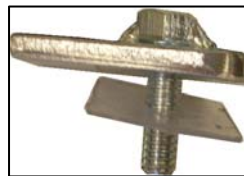

Passenger/Right side Front Mounting Bracket



Driver/Left side Front Mounting Bracket

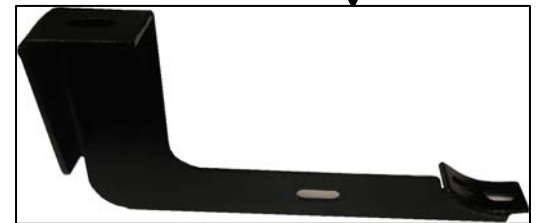

Passenger/Right side Rear Brace Bracket



Passenger/Right side Front Brace Bracket



Driver/Left side Rear Brace Bracket



Driver/Left side Front Brace Bracket



## PROCEDURE:

**1. REMOVE CONTENTS FROM BOX. VERIFY ALL PARTS ARE PRESENT. READ INSTRUCTIONS CAREFULLY BEFORE STARTING INSTALLATION.**

**Note:** Included in this mount kit there is extra hardware, which is used for different models and years. Please review Instructions for the list of hardware needed for your vehicle.

2. Starting at the Passenger/Right side-front of the vehicle, remove the tape covering the factory oval holes in the passenger side inner panel located by the front tire. **(Fig1)** shows location of hole.
3. Next, from the parts list above partially thread a Plastic Retainer onto the threaded end of a Bolt Plate.
4. Once you have assembled the Plastic Retainer onto the Bolt Plate, insert the Bolt Plate into the factory oval hole. Once the Bolt Plate is inserted, hold the Bolt end with one hand and tighten the Plastic Retainer with your other hand. **NOTE:** Tighten the Plastic Retainer until it reaches the side panel, **(Fig 1A)**. Shows Bolt Plate installed with plastic retainer.
5. From the parts list above, select the Passenger/Right side front brace bracket. Position the brace bracket onto the installed Bolt Plate. Secure it with (1) 10mm x 30 OD flat washers, (1) 10mm lock washers and (1) 10mm Hex Nuts, **(Fig 2)**. Shows brace bracket installed with hardware. Snug but do not tighten hardware.
6. Starting at the Passenger/Right side-front of the vehicle, remove the front factory body bolt & washer. (not re-used) **(Fig 3)**, Shows location of body bolt & washer to be removed. From the parts list above select the Passenger/Right side front mounting bracket and secure it with (1) 12mm x 120mm Hex Bolt, (1) 12mm x 44 OD Flat Washer, (1) 12mm Lock Washers, Secure front brace bracket, to the installed front mounting bracket with (1) 10mm x 30mm hex bolt, (2) 10mm x 30 OD flat washers, (1) 10mm lock washers and (1) 10mm Hex Nuts, **(Fig 4)** shows mounting bracket attached . Snug but do not tighten hardware at this time.
7. Moving to the Passenger/Right side rear of the vehicle, remove the tape covering the factory oval hole in the inner body panel **(Fig 5)** shows location of hole.
8. Thread a Plastic Retainer onto the threaded end of a Bolt Plate; Insert the Bolt Plate into the factory hole. Once the Bolt Plate is inserted, hold the Bolt end with one hand and tighten the Plastic Retainer with your other hand, **NOTE:** Tighten the Plastic Retainer until it reaches the side panel. **(Fig 5A)** Shows Bolt Plate installed with plastic retainer.
9. From the parts list above, select the Passenger/Right side rear brace bracket. Position the brace bracket onto the installed Bolt Plate. Secure it with (1) 10mm x 30 OD flat washers, (1) 10mm lock washers and (1) 10mm Hex Nuts, **(Fig 6)**. Shows brace bracket installed with hardware. Snug but do not tighten hardware.

10. Begin to remove the rear factory body bolt, Isolator & washer. (not re-used) **(Fig 7)**, Shows location of body bolt Isolator & washer to be removed. From the parts list above select the Passenger/Right side rear mounting bracket and secure it with (1) 12mm x 120mm Hex Bolt, (1) 12mm x 44 OD Flat Washer, (1) 12mm Lock Washers **(Fig 7A)** shows mounting bracket attached . Snug but do not tighten hardware at this time.
11. Secure rear brace bracket, to the installed rear mounting bracket with (1) 10mm x 30mm hex bolt, (2) 10mm x 30 OD flat washers, (1) 10mm lock washers and (1) 10mm Hex Nuts, **(Fig 8)** shows brace bracket attached . Snug but do not tighten hardware at this time.
12. Next, select the passenger sidebar and fasten it to the front Mounting Bracket with the included (2) 10mm x 30mm Hex Head Bolt, (2) 12mm Lock Washer, and (2) 12mm x 24 OD Flat Washer **(Fig 9)**. Do not tighten at this time. Repeat this step for rear Sidebar mounting.
13. Level and align Sidebar properly; then tighten all hardware at this time.
14. Repeat steps 2-12 for Driver/Left Sidebar.
15. Do periodic inspections to the installation to make sure all hardware is secure and tight.

**To protect your investment**, wax this product after installing. Regular waxing is recommended to add a protective layer over the finish. Do not use any type of polish or wax that may contain abrasives that could damage the finish.

**For stainless steel:** Aluminum polish may be used to polish small scratches and scuffs on the finish. Mild soap may be used also to clean the Sidebar.

**For gloss black finishes:** Mild soap may be used to clean the Sidebar.

### **PASSENGER SIDE INSTALLATION PICTURED**

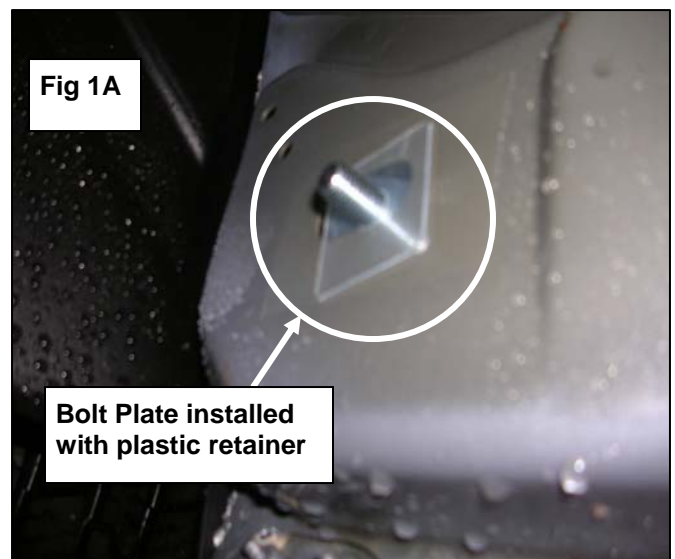
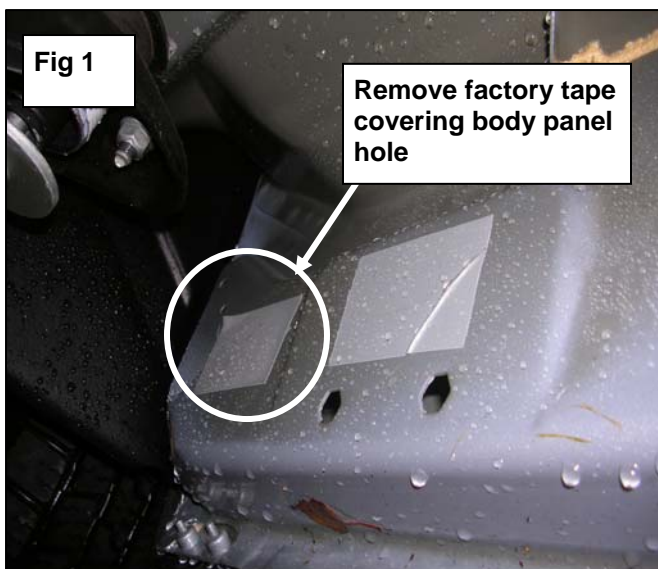

**PASSENGER SIDE INSTALLATION PICTURED**

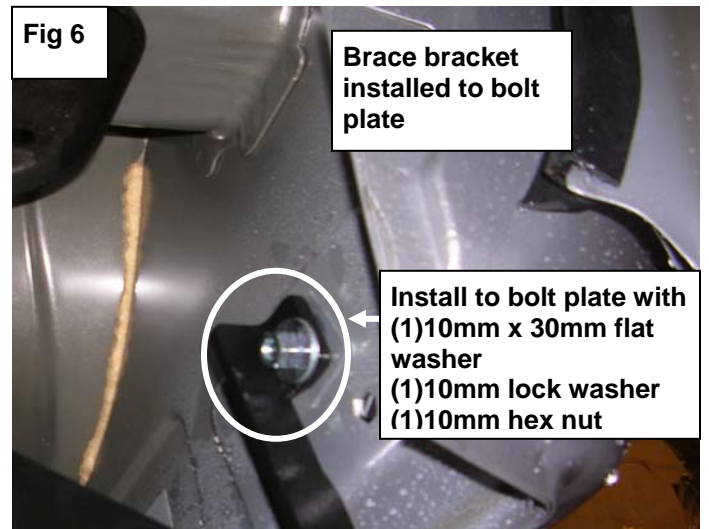
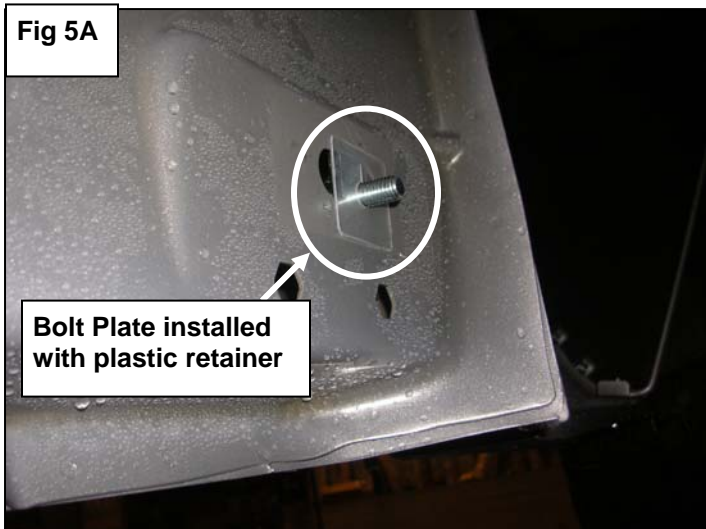
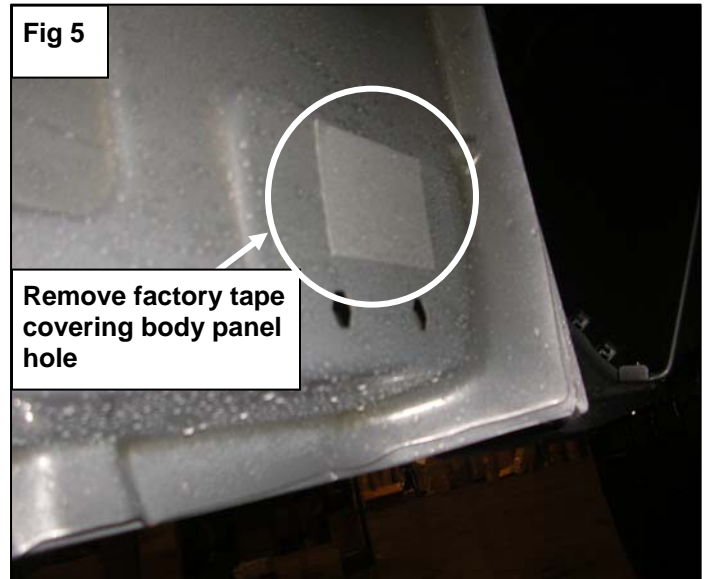
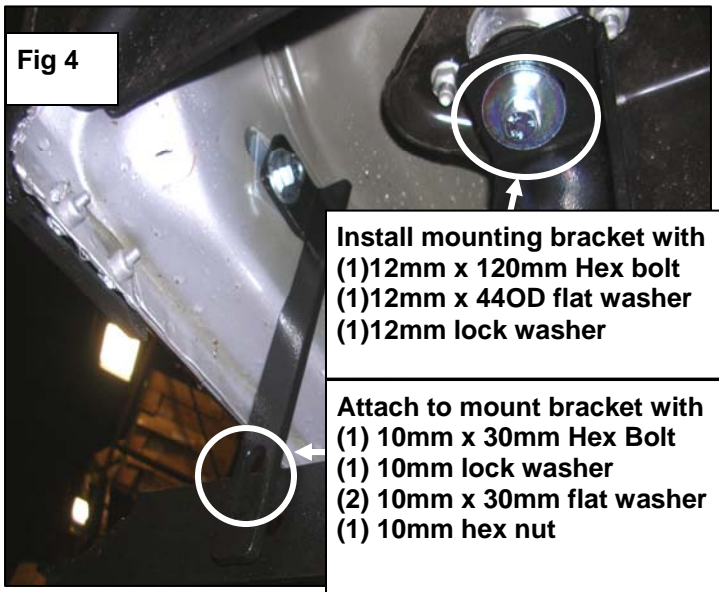
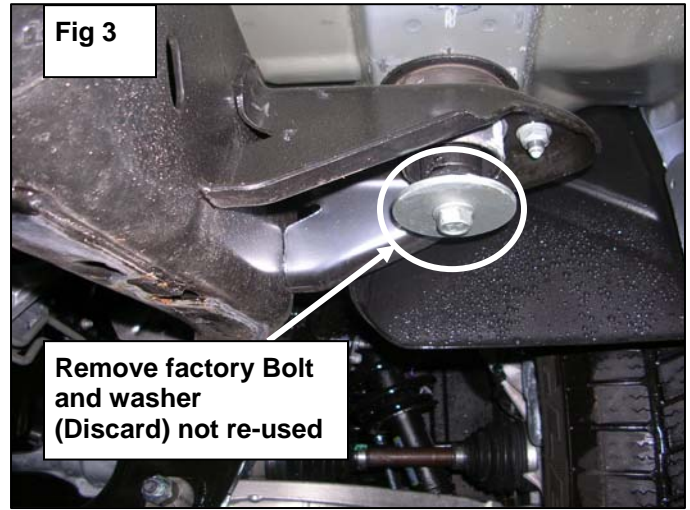
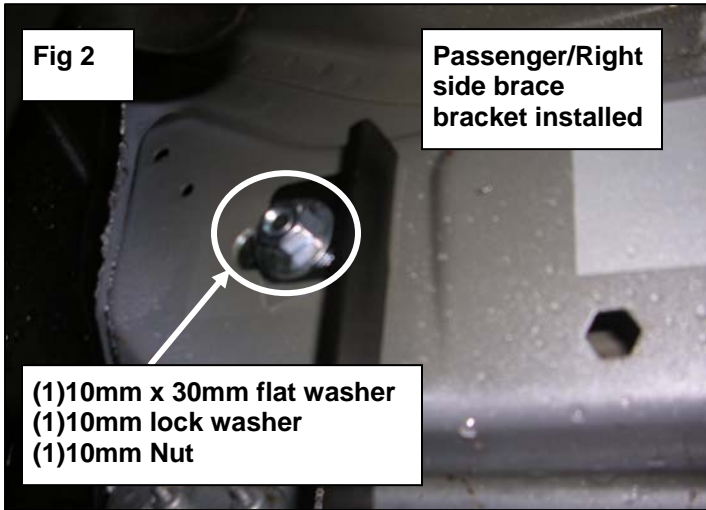



**PASSENGER SIDE INSTALLATION PICTURED**

