

INSTALLATION INSTRUCTIONS

1999-11 1500-2500-3500 SILVERADO/SIERRA EXT CAB

PART NUMBER 224009/224009-2

PARTS LIST:

1	Passenger Side Bar	2	Center Support Brackets 2011
1	Driver Side Bar	2	10mm x 47mm bolt tab
1	Passenger Side Front Mounting Bracket	18	10-1.50mm x 30mm Hex Head Bolts
1	Driver Side Front Mounting Bracket	6	10mm Hex Nuts
1	Passenger Side Center Mounting Bracket	20	10mm Lock Washers
1	Driver Side Center Mounting Bracket	24	10mm ID x 22mm OD x 1.5mm Flat Washers
1	Passenger Side Rear Mounting Bracket	2	10mm Nut Plates
1	Driver Side Rear Mounting Bracket	2	12-1.75mm x 30mm Hex Head Bolts
2	Front Support Bracket 99-10	2	12mm Hex Nuts
2	Center Support Brackets 99-10	4	12mm ID x 29mm x 3mm Flat Washers
2	Front Support Bracket 2011	2	12mm Lock Washers

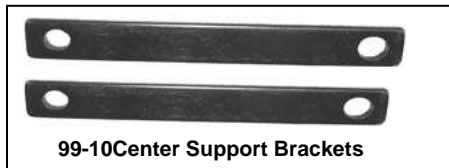
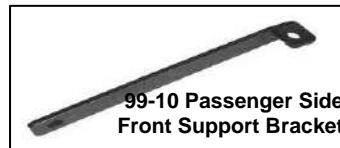
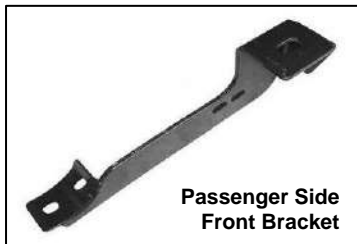

10mm Bolt tabs



2011 Passenger Side Front Support Bracket 2500/3500 Models

2011 Passenger Side Middle Support Bracket 2500/3500 Models

2011 Driver Side Middle Support Bracket 2500/3500 Models

2011 Driver Side Front Support Bracket 2500/3500 Models

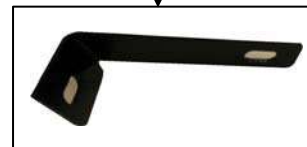

PROCEDURE:

1. **REMOVE CONTENTS FROM BOX. VERIFY ALL PARTS ARE PRESENT. READ INSTRUCTIONS CAREFULLY BEFORE STARTING INSTALLATION.**
2. From underside of vehicle remove front, center, and rear body mount bolts. Do not remove bushings.
3. Hang driver side front, center and rear Mounting Brackets into position by partially threading factory body mounting bolts back into body mounts **(Fig 1)**.
4. Locate the two factory holes in the bottom of the frame towards the front of the vehicle. Insert (1) Nut Plate through oval hole and orient Nut Plate towards the front round hole, **(Fig 2)**.
5. Attach driver side front Support Bracket to already inserted Nut Plate by partially threading (1) 10mm x 30mm Hex Head Bolt, (1) 10mm Lock washer, and (1) 10mm Flat Washer **(Fig 3 & 4)**.

(1999-11) Front brace brackets 1500 Models:

Attach opposite side of driver side front Support Bracket to outside hole in the Mounting Bracket using the included (1) 10mm x 30mm Hex Head Bolt, (1) 10mm Hex Nut, (1) 10mm Lock Washer, and (2) 10mm Flat Washers **(Fig 3)**. Do not tighten at this time.

(1999-10) Front brace brackets 2500 Models:

Note that the Support Bracket will not reach the Mounting Bracket **(Fig 4)**. Tighten the Support Bracket to Nut Plate in the frame. Carefully push up on the Support Bracket until it reaches the inside hole in the Mounting Bracket **(Fig 5)**. Attach opposite side of driver side front Support Bracket to inside hole in the Mounting Bracket using the included (1) 10mm x 30mm Hex Head Bolt, (1) 10mm Hex Nut, (1) 10mm Lock Washer, and (2) 10mm Flat Washers **(Fig 6)**. Do not tighten at this time.

(2011) Front brace brackets 2500 Models:

Attach driver side front Support Bracket to the already inserted Nut Plate by partially threading (1) 10mm x 30mm Hex Bolt, (1) 10mm Lock washer, and (1) 10mm Flat Washer as seen in **(Fig 7)**

Attach opposite side of driver side front Support Bracket to outside hole in the Mounting Bracket using the included (1) 10mm x 30mm Hex Head Bolt, (1) 10mm Hex Nut, (1) 10mm Lock Washer, and (2) 10mm Flat Washers **(Fig 7A)**. Do not tighten at this time.

(1999-11) 1500 and (1999-10) 2500 Models Middle brace brackets

6. From the inner side of the center body mount, place (1) Center Support Bracket onto front side of the body mount. Attach Center Support Bracket to body mount using the included (1) 12-1.75mm x 30mm Hex Head Bolt, (1) 12mm Hex Nut, (1) 12mm Lock Washer, and (2) 12mm Flat Washers **(Fig 8 & 9)**. Do not tighten at this time. **NOTE:** Larger hole on the Center Support Bracket mounts to body mount.
7. Attach opposite side of Center Support Bracket to center Mounting Bracket using the included (1) 10-1.50mm x 30mm Hex Head Bolts, (1) 10mm Hex Nuts, (1) 10mm Lock Washers, and (2) 10mm Flat Washers **(Fig 8 & 9)**. Do not tighten at this time.
8. **(2011) 2500 Models: Middle brace brackets**
Located just above the mount bracket there is a oblong hole as seen in **(Fig 10)** place the bolt tab in the hole, select the driver side brace bracket and secure it to the bolt tab with (1) 10mm Hex Nut, (1) 10mm Lock Washer, and (1) 10mm Flat Washers attach opposite side of driver side middle Support Bracket to inside hole in the Mounting Bracket using the included (1) 10mm x 30mm Hex Head Bolt, (1) 10mm Hex Nut, (1) 10mm Lock Washer, and (2) 10mm Flat Washers **(Fig 10A)**. Do not tighten at this time.
9. Carefully position Driver Side Bar onto Mounting Brackets. Attach Side Bar to Mounting Brackets using the included (6) 10-1.50mm x 30mm Hex Head Bolts, (6) 10mm Lock Washers, and (6) 10mm Flat Washers **(Fig 11)**. Do not tighten at this time.
10. Level and adjust Side Bar, then tighten all hardware at this time.
11. Repeat steps 2-9 for passenger Side Bar.
12. Do periodic inspections to the installation to make sure that all hardware is secure and tight.

To protect your investment, wax this product after installing. Regular waxing is recommended to add a protective layer over the finish. Do not use any type of polish or wax that may contain abrasives that could damage the finish.

For stainless steel: Aluminum polish may be used to polish small scratches and scuffs on the finish. Mild soap may be used also to clean the Sidebar.

For gloss black finishes: Mild soap may be used to clean the Sidebar.

Driver Side Installation Pictured

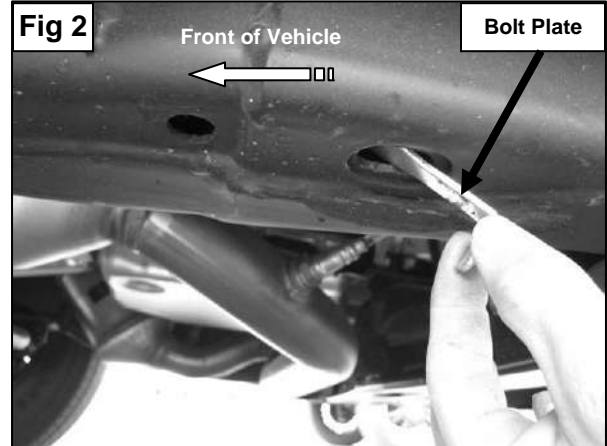
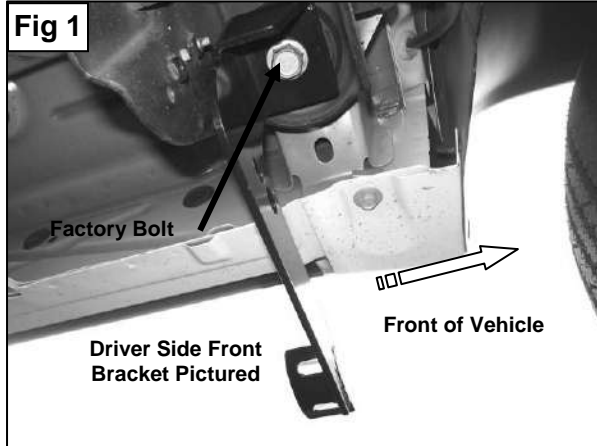

1999-11 1500 Model Front Installation Pictured

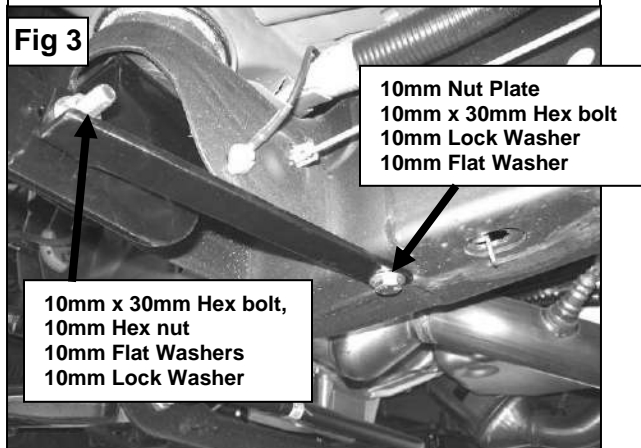

1999-10 2500 Model Front Installation Pictured

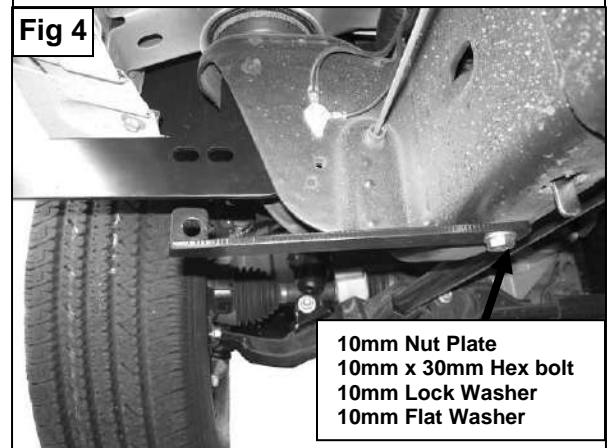

99-10 2500 Model Front Installation Pictured

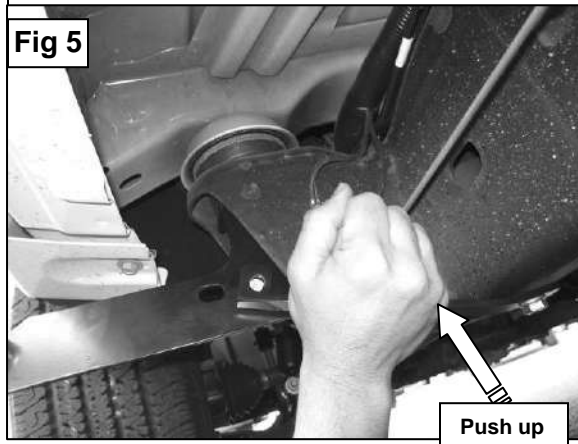

99-10 2500 Model Front Installation Pictured

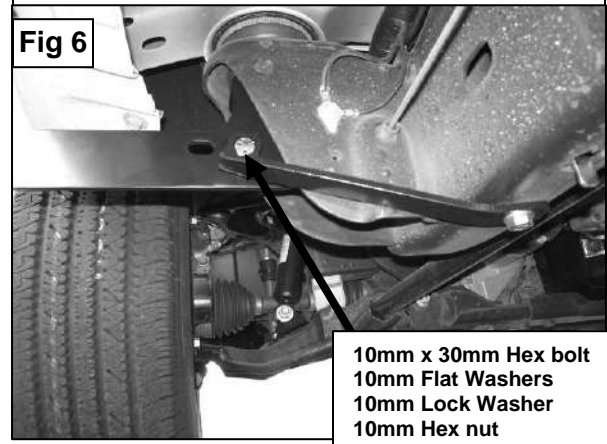

2011 2500 Model Front Installation Pictured

Fig 7

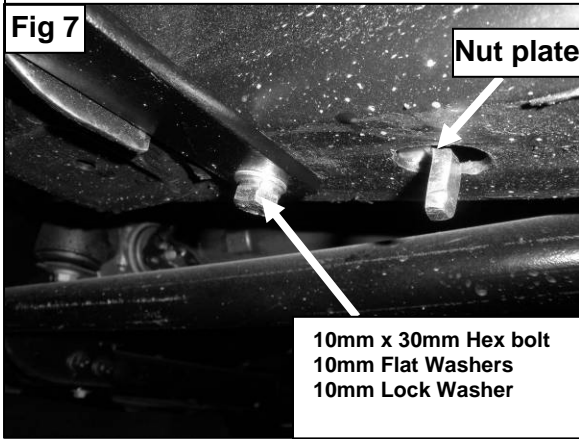

2011 2500 Model Center Installation Pictured

Fig 7A

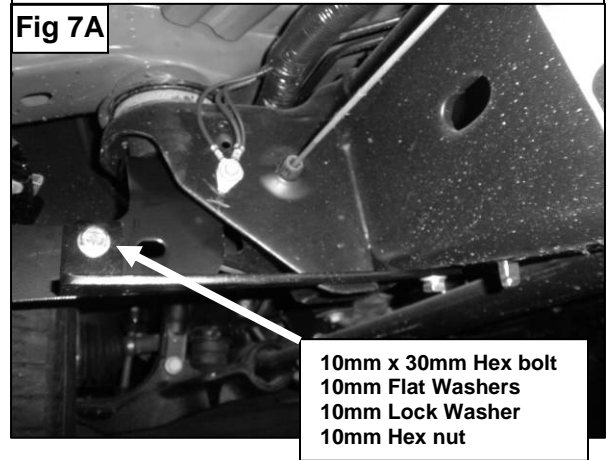

1500 Model Center Installation Pictured

Fig 8

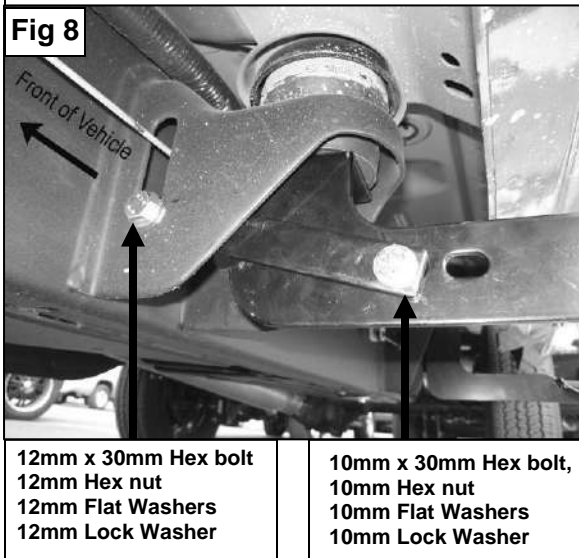

99-10 2500 Model Center Installation Pictured

Fig 9

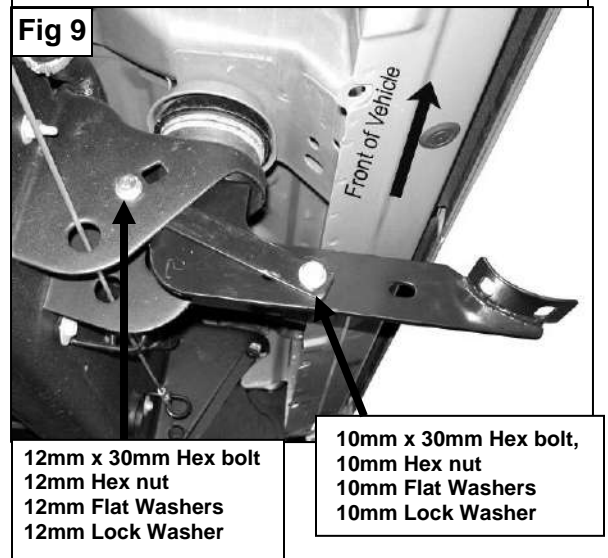

2011 2500 Model Center Installation Pictured

Fig 10

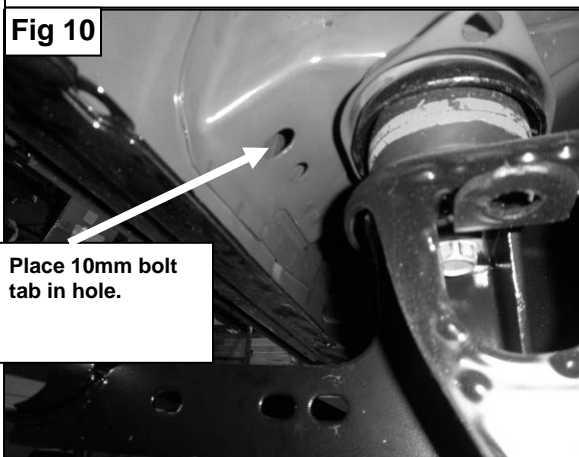

2011 2500 Model Center Installation Pictured

Fig 10A

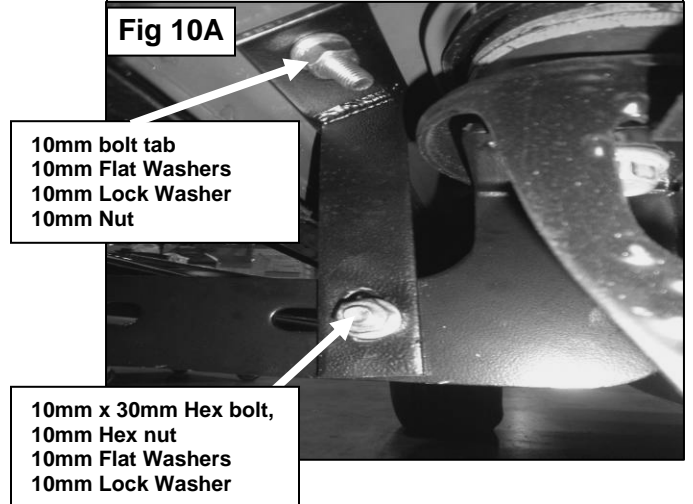
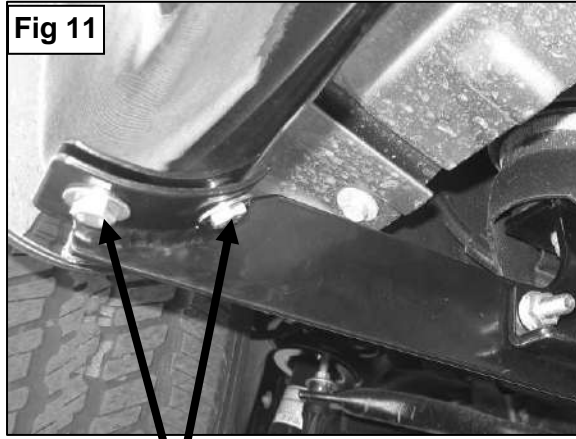

Fig 11



**10mm x 30mm Hex bolt,
10mm Lock Washer
10mm Flat Washer**

Installation Complete



INSTALLTION ALERT

General Motors has made changes to their late model 2010 and 2012 Chevrolet Silverado and GMC Sierra Light Duty and Heavy Duty Trucks and these changes affect the installation of our Side Bars.

Currently, all Side Bars manufactured for GM trucks use the factory body mount bolts to attach the bars and brackets to the truck. In years past, GM used a fixed nut that was welded in place to the chassis of the truck. Starting late 2010, GM has now gone to a loose nut that is surrounded by a "Cage Nut" which has two tabs on either side of the nut to keep it from loosening. Along with this cage nut, GM is also using Heavy Duty Loc-tite on the Body Mount Bolts for added protection.

Due to this change, Aries is recommending **EXTREME CARE** when removing the factory body mount bolts from these trucks. **Loosen and re-tighten all body mount bolts by hand! DO NOT use Impact Tools of any kind!** If bolts become increasingly tight as you are loosening them you may need to retighten & loosen the bolt several times to clear the loc-tite from the threads Failure to follow this instruction could cause the body mount bolts to seize and the tabs of the 'Cage Nut' to bend allowing the nut to spin freely inside Chassis floor board!

Most of clients have been installing the existing side bar applications on these new trucks with no issues, but please be sure to follow our recommendation to prevent any installation issues.

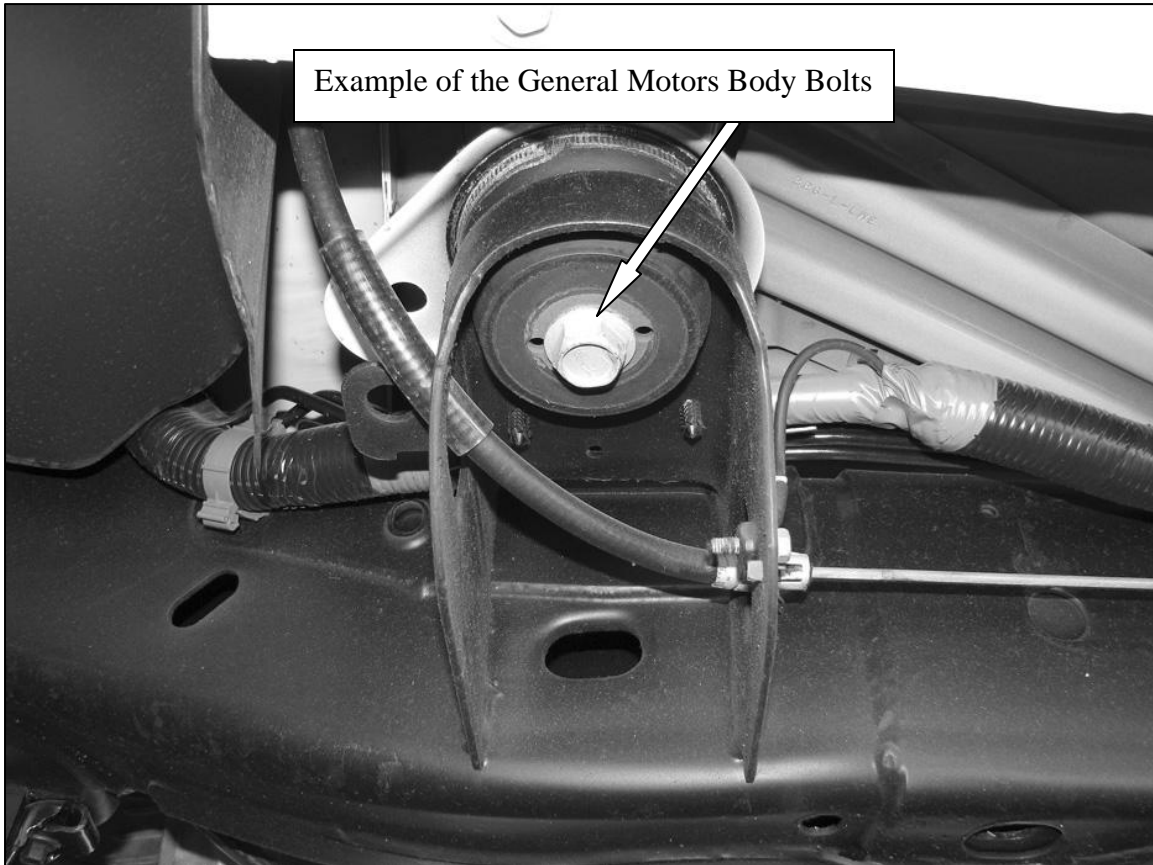

[Learn more about other running boards and step bars by Aries on our website.](#)