



**INSTALLATION INSTRUCTIONS**

**3" BULL BAR**

**2017 FORD SUPER DUTY F250-F350**

**PART # 35-3014 / B35-3014**

**PARTS LIST:**

1	Bull Bar	4	10-1.5mm x 30mm Hex Bolts
1	Driver/left Frame Mounting Bracket	8	10mm x 27mm OD x 3mm Flat Washers
1	Passenger/right Frame Mounting Bracket	4	10mm Nylon Lock Nuts
2	Spacer Plates		



**! NOTICE** Bull Bar may interfere with the performance of forward facing cameras and sensors , if equipped.

**PROCEDURE:**

**REMOVE CONTENTS FROM BOX. VERIFY ALL PARTS ARE PRESENT. READ INSTRUCTIONS CAREFULLY BEFORE STARTING INSTALLATION. ASSISTANCE IS RECOMMENDED.**

**NOTE:** It may be necessary to remove/relocate front license plate and bracket. It is not required, but strongly recommended. If local/state law requires a license plate, license plate relocation kit is available.

1. Start installation at the driver/left side, front of the vehicle. Remove the plastic cover, (if equipped), covering the bumper bolts on both sides of the tow hook, **(Figure 1)**. Remove the (2) outer bumper bolts, **(Figures 2 & 3)**. **IMPORTANT:** Do not remove the inner bumper bolts or the bumper may fall. Only remove the outer bumper bolts. **NOTE:** Cover cannot be reinstalled.
2. Select the driver side Frame Bracket and (1) Spacer Plate, **(Figure 4)**. Place the Spacer over the holes for the bumper bolts. Reuse the factory bumper bolts to attach the Frame Bracket to the Spacer and bumper, **(Figure 5)**. Make sure there is clearance between the top and bottom of the Frame Bracket and the opening in the bumper. Do not tighten hardware at this time.
3. Repeat **Steps 1 & 2** for passenger/right side Frame Bracket and Spacer installation.
4. With assistance, position the Bull Bar onto the outside of the (2) Mounting Brackets. **NOTE:** Move the Mounting Brackets in or out as required to line up with the mounting tabs on the Bull Bar.
5. Attach the Bull Bar to the outside of the Mounting Brackets using the included (4) 10mm x 30mm Hex Bolts, (8) 10mm Flat Washers, (4) 10mm Nylon Lock Nuts, **(Figures 6 & 7)**. Snug but do not tighten hardware at this time.
6. Center the Bull Bar on the vehicle, level and adjust as desired and tighten all hardware at this time.
7. Do periodic inspections to the installation to make sure that all hardware is secure and tight.

**To protect your investment**, wax this product after installing. Regular waxing is recommended to add a protective layer over the finish. Do not use any type of polish or wax that may contain abrasives that could damage the finish.

**For stainless steel:** Aluminum polish may be used to polish small scratches and scuffs on the finish. Mild soap may be used also to clean the Bull Bar.

**For gloss black finishes:** Mild soap may be used to clean the Bull Bar.

**Driver/left Side Installation Pictured**



**(Fig 1) Remove cover over bumper bolts**



**Fig 2**

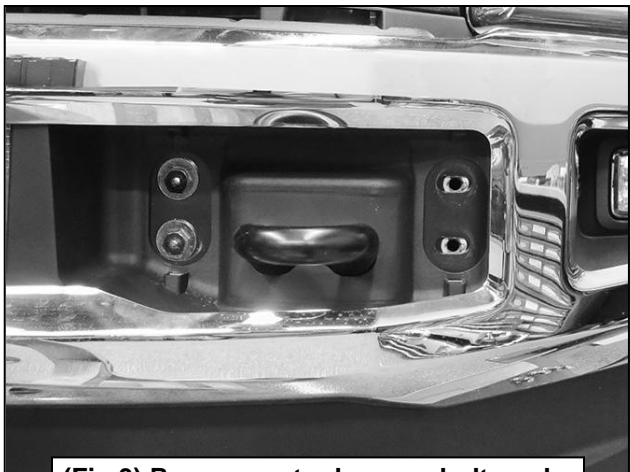

**(Fig 3) Remove outer bumper bolts only  
(driver/left front of bumper pictured)**

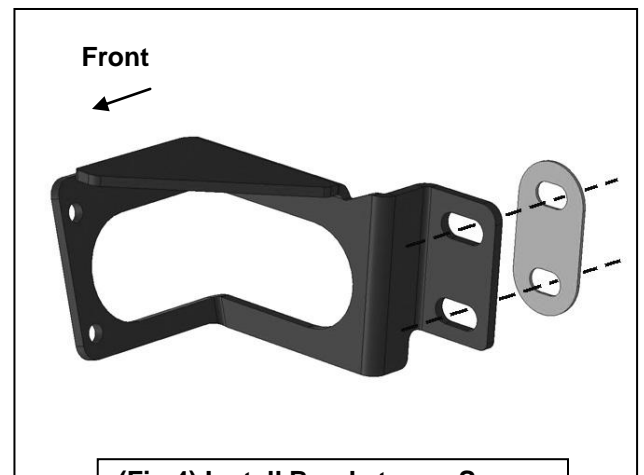

**(Fig 4) Install Bracket over Spacer**

### Driver/left Side Installation Pictured

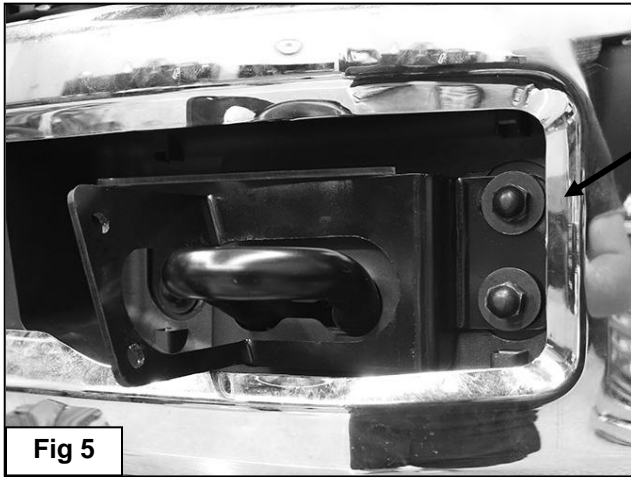

Reuse factory bumper bolts to attach Bracket and Spacer to Bumper

- (2) 10mm x 30mm Hex Bolts
- (4) 10mm Flat Washers
- (2) 10mm Nylon Lock Nuts

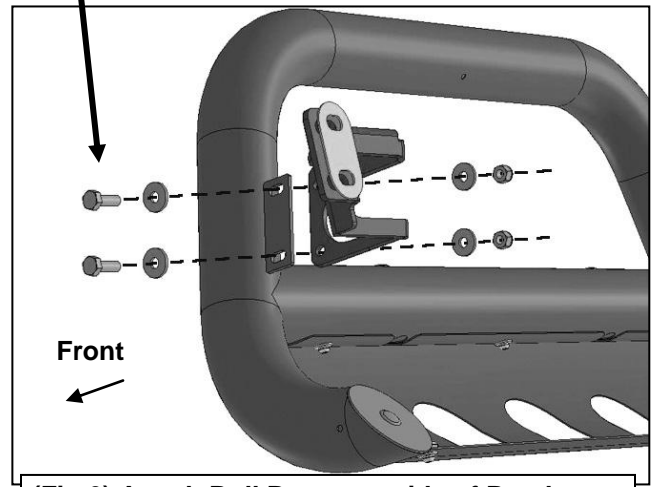

(Fig 6) Attach Bull Bar to outside of Brackets

- (2) 10mm x 30mm Hex Bolts
- (4) 10mm Flat Washers
- (2) 10mm Nylon Lock Nuts



(Fig 7) Driver/left side complete installation

