



INSTALLATION MANUAL

Parts List

1	Bull bar
2	Driver / left mounting bracket
2	Passenger / right mounting bracket
6	Hex bolt, M8
6	Flat washer, M8
6	Nylock nut, M8
4	Hex bolt, M10
8	Flat washer, M10
4	Nylock nut, M10
1*	LED wiring harness*

* Wiring harness only included with LED equipped models

Tools Required

Ratchet	Socket, 13mm
Extension	Socket, 16mm
Level	Socket, 18mm
Wrench, 17mm	

Torque Specifications

	METRIC	SAE
M6 bolt	3 ft.-lbs.	
M8 bolt	7 ft.-lbs.	
M10 bolt	16 ft.-lbs.	
M12 bolt	28 ft.-lbs.	
1/4" bolt		3 ft.-lbs.
5/16" bolt		7 ft.-lbs.
3/8" bolt		16 ft.-lbs.
7/16" bolt		20 ft.-lbs.
1/2" bolt		28 ft.-lbs.

Level of Difficulty

Easy

Product Image



2153002

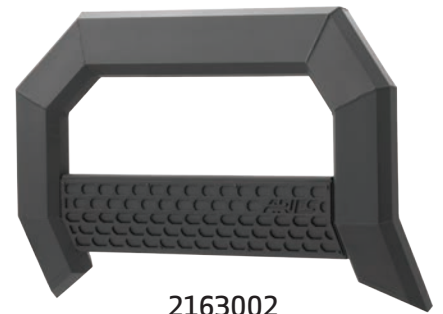

2163002



2153102



2163102

Notes and Maintenance

Before you begin installation, read all instructions thoroughly.

Proper tools will improve the quality of installation and reduce the time required.

For chrome powder coat, polish may be used to clear small scratches and scuffs on the finish. Mild soap may be used also to clean the product.

For black finishes, mild soap may be used to clean the product.

Refer to the table to the left when securing hardware during the installation process to help prevent damage to the product or vehicle.

Step 1

Starting on the driver side, remove the two factory hex bolts.



Step 2

Secure the driver-side mounting bracket to the vehicle using the previously removed hex bolts.

Snug the hardware, but do not fully tighten.



Step 3

Repeat steps 1 and 2 to attach the passenger-side mounting bracket.



Step 4

To attach the bull bar mounting brackets, lay the bull bar on a flat surface.

Insert three M8 hex bolts into the inner rail slot.

Place the driver-side bracket over the bolts and secure the bracket to the bull bar using an M8 flat washer and M8 nylock nut.

Snug the hardware, but do not fully tighten. Repeat this step for the passenger-side bracket.



Step 5

With help, lift the bull bar into place and align the mounting tabs on the inside of the mounting brackets.

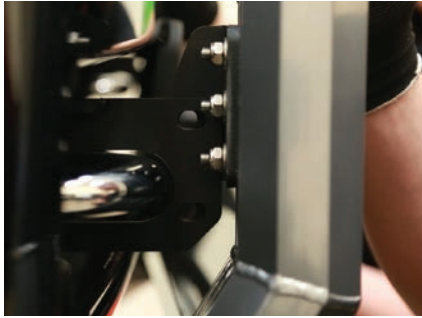

Step 6

Insert a M10 hex bolt with flat washer on the outside of the bracket and a M10 flat washer and nylock nut on the inside.

Snug the hardware, but do not fully tighten.

Repeat this process for all mounting locations.

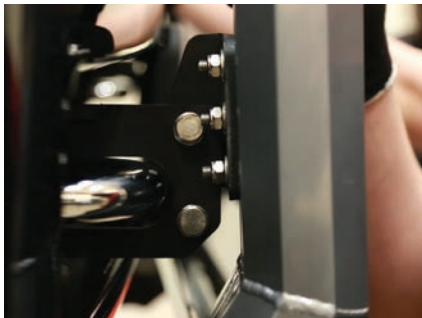

Step 7

Level and adjust the bull bar into the desired position and tighten all hardware.

Tighten all hardware to the recommended torque specifications listed in the table on the first page.

If your bull bar is not equipped with lights skip to step 10.

If your bull bar is equipped with lights complete steps 8 and 9.

Note: If the LED lights are being used with a 24V system, the 12V relay will need to be replaced with a 24V unit.



Step 8 - For Models with LED Lights Included

Disconnect the supplied switch from the wire harness and install in desired location.

With the switch installed, route the wire harness to the LED lights and the switch.

Reconnect the blue, red and black spade connectors to the switch as shown.

Note: The black wire connects to the gold switch terminal.

Plug the male connector on the wire harness into the female connector attached to the LED lights.



Step 9 - For Models with LED Lights Included

Connect the red fused wire with the ring terminal to the positive battery post.

Connect the black wire ring terminal to the negative battery post or other suitable vehicle grounding point.

Mount the supplied relay to the vehicle and secure all wires with zip ties away from moving parts to avoid damage.

Test the lights to ensure proper function.

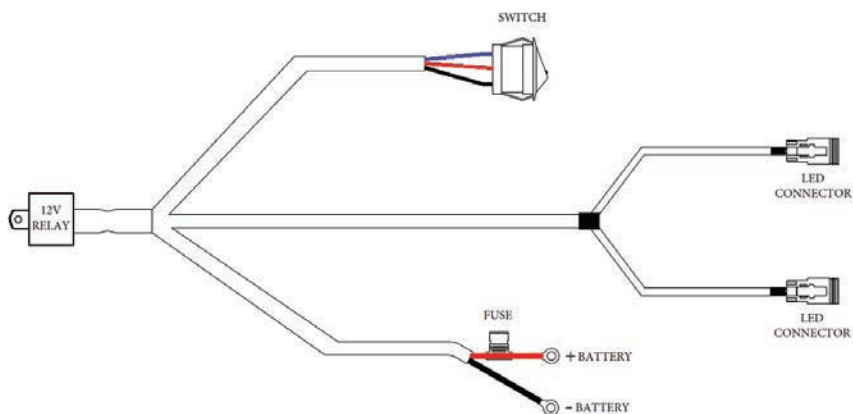

Step 10

Congratulations on the installation of your new ARIES AdvantEDGE™ bull bar.

With the bull bar installed, periodic inspections should be performed to ensure all mounting hardware remains tight.

To protect your investment, see the 'Notes and Maintenance' section on the first page of this instruction manual.

