

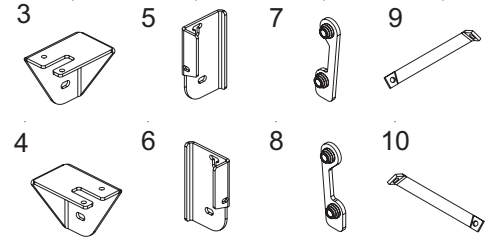

1998-09 RANGER EDGE SUPER CAB
 1998-09 MAZDA B-SERIES P/U SUPER CAB
 Part # 203033 / 203033-2

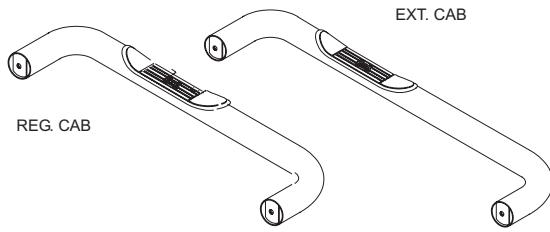

ITEM	QTY	CONTENTS -	TOOLS -
1,2	2	STEP BAR, PASSENGER (1) AND DRIVER (2)	3/4" SOCKET
3,4	2	FRONT BRACKET, PASSENGER (3) AND DRIVER	9/16" SOCKET
5,6	2	REAR BRACKET PASSENGER (5) AND DRIVER (6) (4)	9/16" WRENCH
7,8	2	MOUNT PLATE ASSEMBLY, PASSENGER (7) AND DRIVER (8)	*7/16" DRILL BIT
9,10	2	SUPPORT BRACE PASSENGER (9) AND DRIVER (10)	*DRILL
11	2	1/2-13 X 2.50" HEX HEAD BOLT	CENTER PUNCH
12	2	1/2-13 X 2.00" HEX HEAD BOLT	HAMMER
13	4	1/2" FLAT WASHER	RATCHET
14	4	1/2" LOCK WASHER	TORQUE WRENCH
15	10	3/8-16 X 1.25" HEX HEAD BOLT	
16	16	3/8" FLAT WASHER	
17	10	3/8" LOCK WASHER	
18	6	3/8-16 HEX NUT	

*NOTE: A SHORT 7/16" BIT WITH A 3/8" SHANK AND A SMALL OR RIGHT ANGLE DRILL MAY BE NECESSARY FOR EASIER INSTALLATION.

- Step 1. Remove the contents from box and check for damage. Verify all parts are present. Read instructions completely before beginning.
- Step 2. Attach front brackets and support braces using 3/8" fasteners as shown. SEE FIGURES 1 THROUGH 3.
- Step 3. Temporarily attach rear bracket to vehicle through hole as shown. SEE FIGURE 4. Carefully cut out templates and align with visible portion of rear bracket. Tape template in place and mark center of top hole with center punch. Remove template and bracket from vehicle. Drill 7/16" diameter hole at this location.
 NOTE: If hole on rocker panel aligns with T-Slot on mount bracket fasten at this location. Drilling is not required.
- Step 4. Attach rear brackets to the backside of rocker panel using 3/8" fasteners as shown. SEE FIGURE 5.
- Step 5. Attach step bars to brackets using 1/2" fasteners as shown. SEE FIGURE 6.
- Step 6. Make sure step bar and brackets are properly aligned with vehicle and tighten fasteners. Recommended torque value is 26 Ft. Lbs. for 3/8" fasteners and 64 Ft. Lbs. for 1/2" fasteners.

FINISH PROTECTION- ARIES PRODUCTS HAVE A HIGH FINISH THAT MUST BE MAINTAINED SUCH AS ANY OTHER HIGH FINISH PRODUCT ON THE VEHICLE. PROTECT THE FINISH WITH A NON-ABRASIVE AUTOMOTIVE WAX. THE USE OF SOAP, POLISH, OR WAX THAT CONTAINS ABRASIVES IS DETRIMENTAL, AS THE COMPOUNDS SCRATCH THE FINISH AND OPEN IT TO CORROSION.

DISCLAIMER- BUYER ASSUMES ALL RISK AND LIABILITY WHATSOEVER FROM THE INSTALLATION AND USE OF ARIES PRODUCTS. ARIES PRODUCTS ARE SOLD AS DECORATIVE ACCESSORIES AND SHOULD NOT BE RELIED UPON AS PROTECTION FOR THE VEHICLE OR OCCUPANTS IN THE EVENT OF A COLLISION OR ROLL OVER. ARIES AUTOMOTIVE ASSUMES NO LIABILITY FOR INJURY, LOSS.

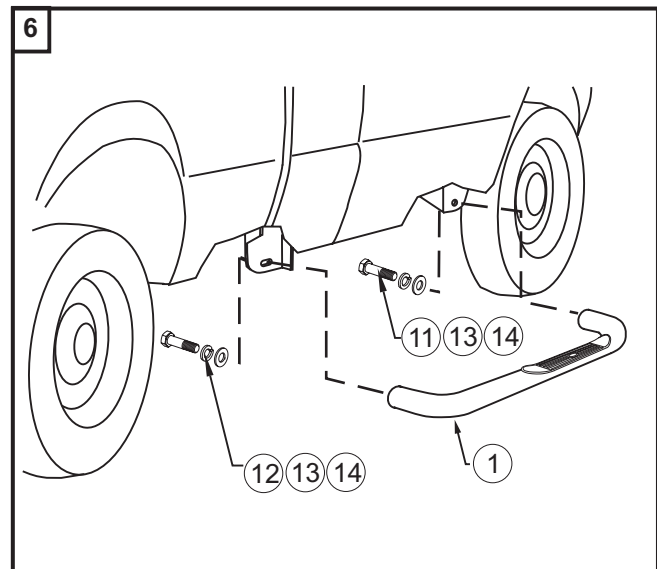
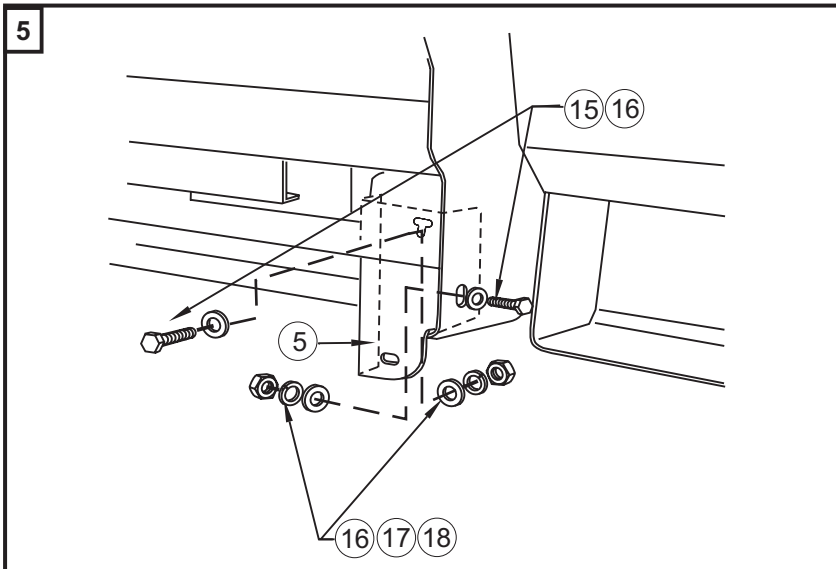
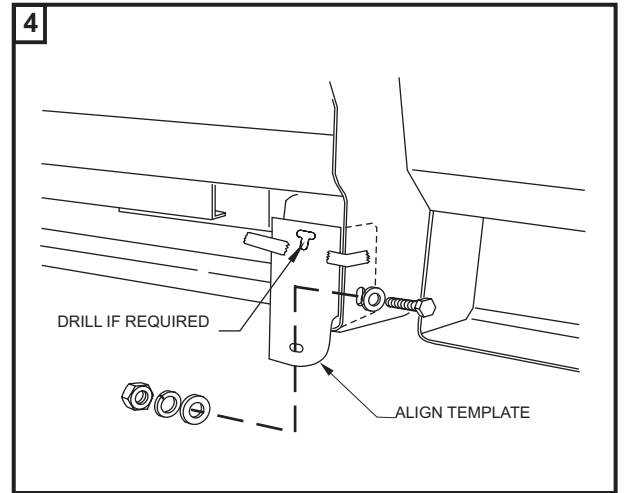
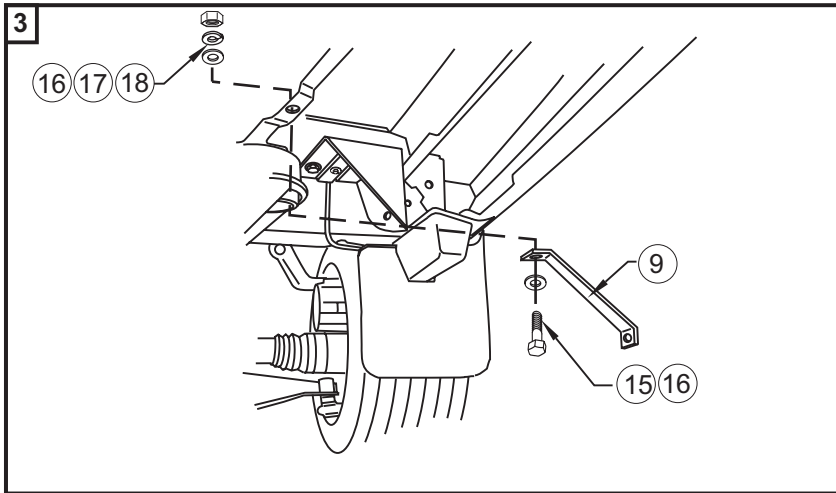
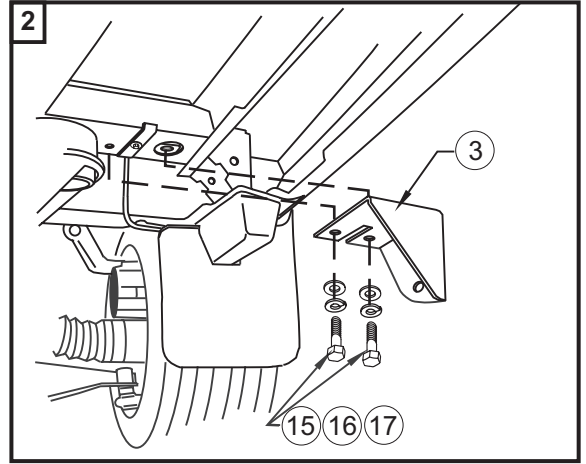
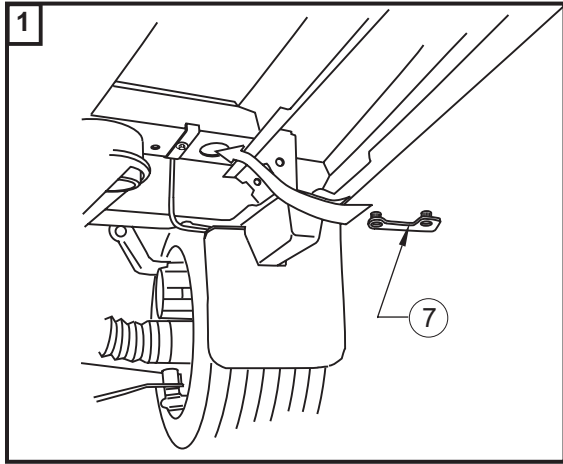

INSTALLATION VIEW OF PASSENGER SIDE SHOWN, DRIVER SIDE OPPOSITE