

INSTALLATION INSTRUCTIONS

1984-2000 JEEP CHEROKEE

PART# 201000 / 201000-2

PARTS LIST

1	Step Bar Assembly, Drivers Side	4	1/2"-13*2Hex Head Bolt
1	Step Bar Assembly, Passenger Side	4	1/2"Flat Washer
2	Front Mounting Brackets	4	1/2"Lock Washer
1	Rear Mounting Bracket, Driver Side	10	3/8*1"Self Tapping Hex Head Bolt
1	Rear Mounting Bracket, Passenger Side		

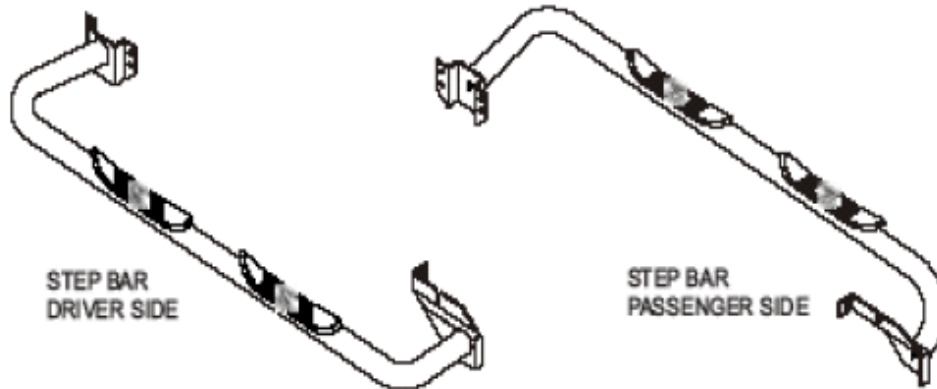

PROCEDURE:

Step 1: Remove all parts from the box and check for any damage. Verify all parts are there.

Step 2: Read and understand all of the instructions before installing.

Step 3: Install both front and rear mounting brackets onto the Step Bars using 4 of the 1/2"-13X2" hex head bolts, 4 1/2" lock washer, and 4 flat washers leaving them loose. See Fig.1

Step 4: Loosen the front rear spring bolt, enough to slide the slotted top edge of the rear bracket can be slid underneath the head bolt. **NOTE: DO NOT REMOVE THIS BOLT.SEE Fig.2**

Step 5: Place the rear of the Step Bar to the Spring Bracket, and tighten the Spring Bolt until it holds the rear Step Bar bracket in place. See Fig.2

Step 6: Hold up the front end of the Step Bar to the front of the sub frame .Check to be sure the Step Bar is properly aligned with the Body and mark the holes to be drilled.

NOTE: On some models be cautious of the diagonal oblong hole, it maybe necessary to locate the front mounting bracket at an angle to miss this hole. See Fig 2.

Step 7: Drill the holes for the front bracket using the 5/16" drill bit and electric drill.

Step 8: Secure the front Mounting Bracket to the sub frame using 4 3/8" self tapping bolts. **NOTE: DO NOT OVER TIGHTEN THESE BOLTS.**

Step 9: Tighten and torque 1/2" fasteners to 65 ft. lbs., 3/8"-16X1 Hex Head Self Tapping Bolts to 20 ft. lbs. And the Spring bolt to 70 ft. lbs.

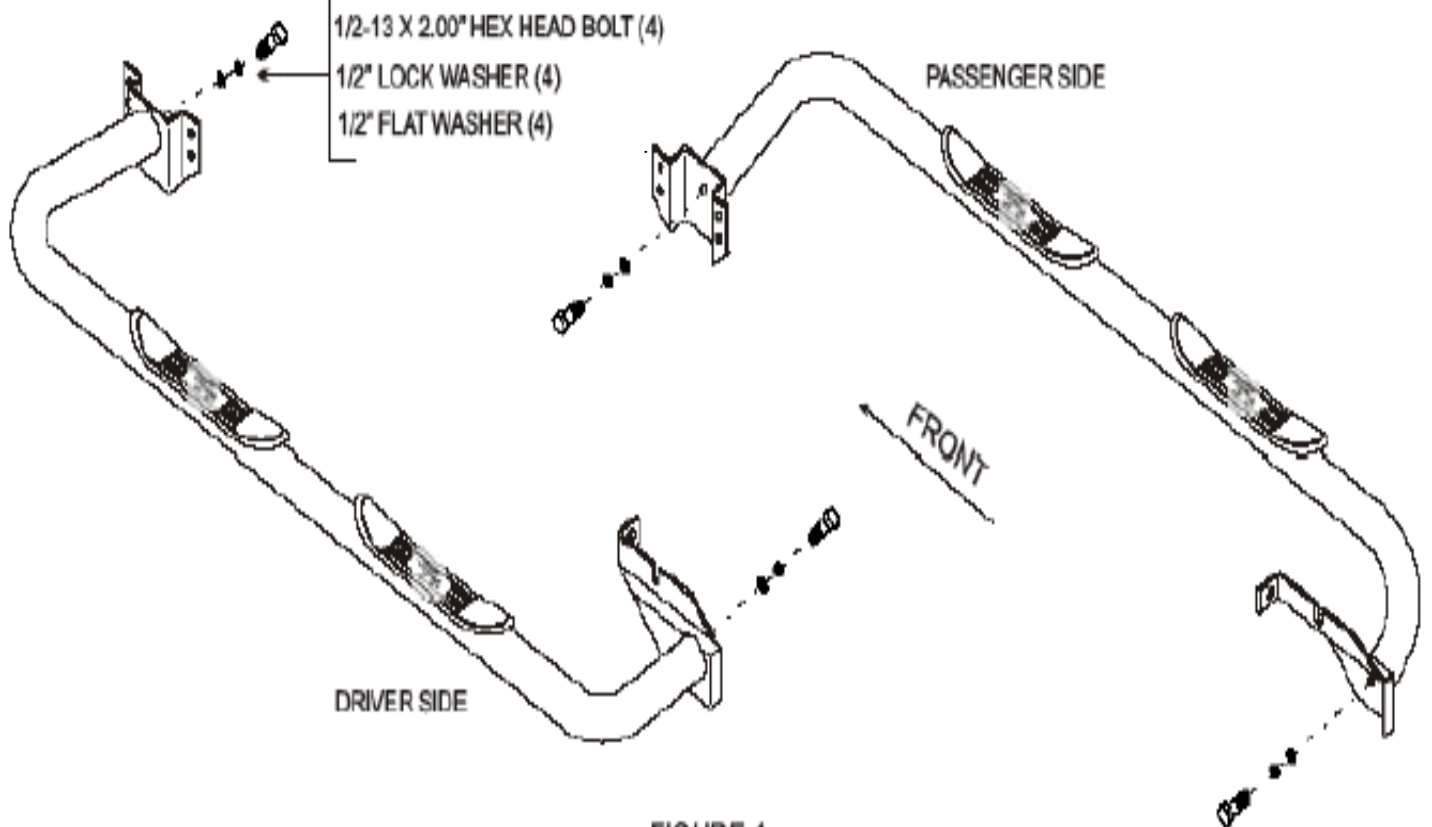

FIGURE 1

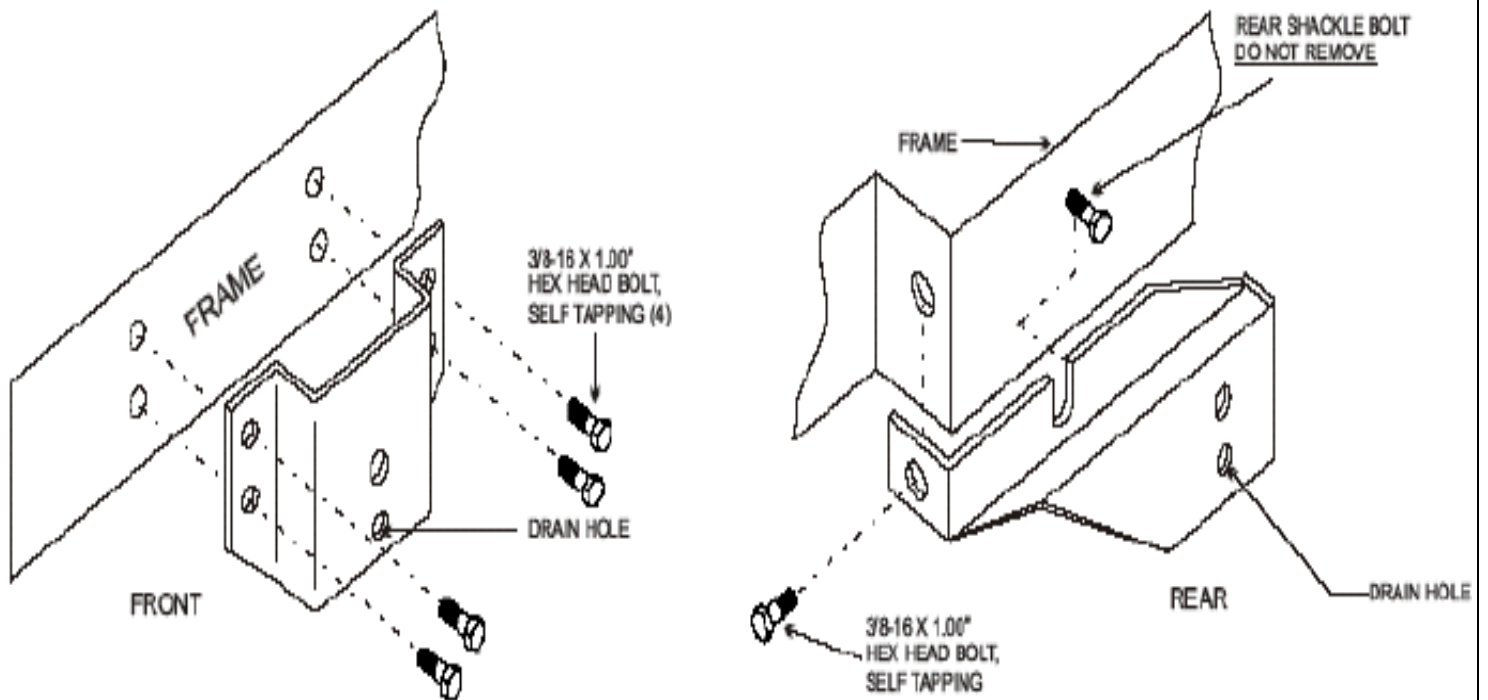

FIGURE 2

ASSEMBLY AND INSTALLATION VIEW OF DRIVER SIDE - PASSENGER OPPOSITE