

INSTALLATION MANUAL

P1053

Level of Difficulty

Easy

Parts List

1	Grille guard
1	Driver / left mounting bracket
1	Passenger / right mounting bracket
1	Driver / left support bracket
1	Passenger / right support bracket
1	Driver / left splash guard bracket
1	Passenger / right splash guard bracket
1	Support flange
4	Hex bolt, M8
2	Hex nut, M8
2	Bolt-nut plate, M8
4	Button head bolt, M8
4	Nylon lock nut, M8
2	Clip nut, M8
14	Flat washer, M8
4	Lock washer, M8
2	Plastic retainer, M8
4	Hex bolt, M10
4	Flat washer, M10
4	Lock washer, M10
6	Hex bolt, M12
6	Hex nut, M12
12	Flat washer, M12
6	Lock washer, M12
--	Allen wrench

Tools Required

Socket set	Wrench set
Ratchet	--

Product Photo



Brackets and Hardware

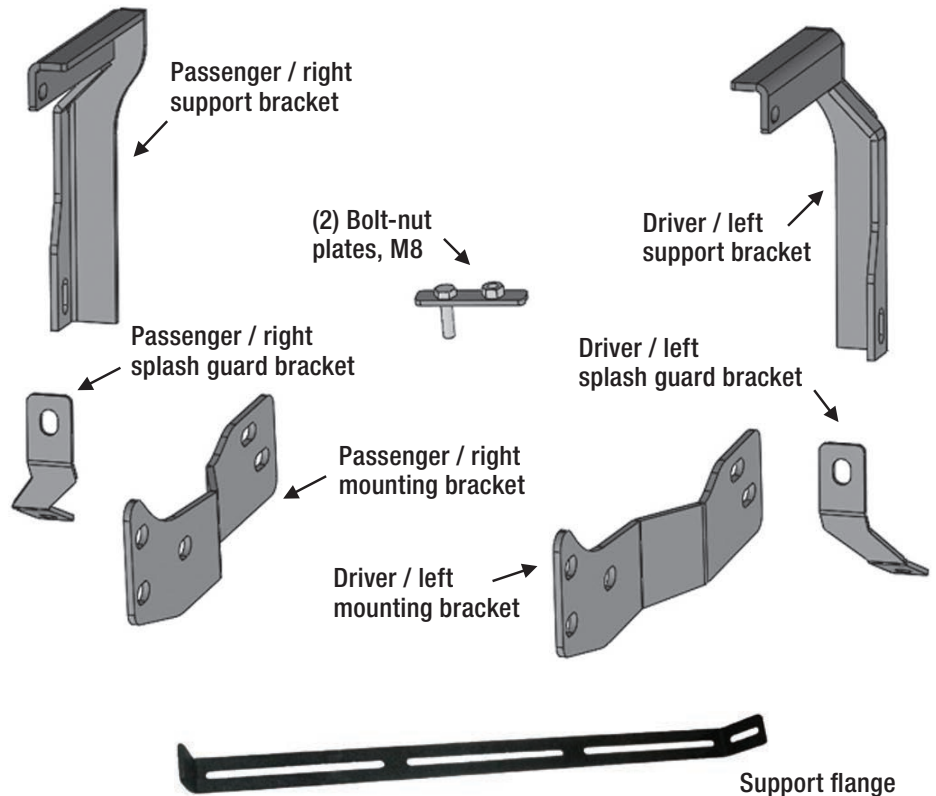

Torque Specifications

	Metric	SAE
M6 bolt	3 ft-lbs.	
M8 bolt	7 ft-lbs.	
M10 bolt	16 ft-lbs.	
M12 bolt	28 ft-lbs.	
1/4" bolt		3 ft-lbs.
5/16" bolt		7 ft-lbs.
3/8" bolt		16 ft-lbs.
7/16" bolt		20 ft-lbs.
1/2" bolt		28 ft-lbs.

Use above torque setting unless otherwise noted

Notes and Maintenance

Before you begin installation, read all instructions thoroughly.

Proper tools will improve the quality of installation and reduce the time required.

To protect the product, wax after installing. Regular waxing is recommended to add a protective layer over the finish. Do not use any type of polish or wax that may contain abrasives that could damage the finish.

For polished, gloss and other smooth finishes, polish may be used to clear small scratches and scuffs on the finish.

Mild automotive detergent may be used to clean the product. Do not use dish detergent, abrasive cleaners, abrasive pads, wire brushes or other similar products that may damage the finish.

Refer to the last page of this manual for warranty and product registration information.

Refer to the table to the left when securing hardware during the installation process to help prevent damage to the product or vehicle.

If you are not installing a light bar, proceed to page 3

Step 1 - Light Bar Installation

Select an LED light (sold separately), mounting hardware and brackets. Attach the hardware to the support flange.

Note: LED manufactures may have different mounting styles or brackets. Once the mounting options are determined, attach it to the support flange.



Step 2 - Light Bar Installation

With the LED light attached to the support flange, place the two M8 nut clips into the slotted holes on either side of the support flange.



Step 3 - Light Bar Installation

Place the grille guard face down and set the support flange into the center flange of the grille guard.

Attach each side of the support flange to the inner brackets on the center flange with two M8 hex bolts, flat washers and lock washers.

Snug the hardware, but do not fully tighten.

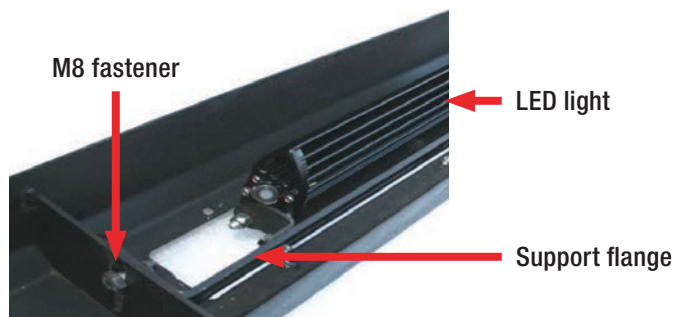

PROCEDURE:

1. **REMOVE CONTENTS FROM BOX. VERIFY ALL PARTS ARE PRESENT. READ INSTRUCTIONS CAREFULLY BEFORE STARTING INSTALLATION. CUTTING IS REQUIRED. ASSISTANCE IS RECOMMENDED.**
2. Starting from underneath the front bumper, remove the plastic lower splash guard, **(Figure 1)**. Also, remove the metal plate behind the plastic splash guard, **(Figure 2)**. From the top of the front bumper, remove the plastic fill panel between the front bumper and grille, **(Figure 3)**.
3. Starting on the driver/left side of the frame, determine if the frame is equipped with threaded inserts.
Models with (2) hexagonal holes in the frame:
 - a. Insert (1) 8mm Bolt-Nut Plate in through the bottom opening of the frame and push the Bolt on the Bolt-Nut plate out through the hexagonal hole on the inside of the frame, **(Figure 4A)**. Thread (1) 8mm Plastic Retainer onto the Bolt on the Bolt-Nut Plate to keep the Plate in place. Align the Nut on the Bolt-Nut Plate to the adjacent hexagonal hole, **(Figure 4B)**. **NOTE:** The Plastic Retainer is used to prevent the Bolt-Nut Plate from falling and help in Mounting Bracket installation.
 - b. Select the Driver/left side Mounting Bracket. Attach the Bracket to the Bolt on the Bolt-Nut Plate using (1) 8mm Flat Washer, (1) 8mm lock Washer and (1) 8mm Hex Nut, **(Figures 5 & 7)**. Attach the Bracket to the Nut on the Plate with (1) 8mm Hex Bolt, (1) 8mm Lock Washer and (1) 8mm Flat Washer, **(Figures 5 & 7)**. Do not tighten hardware at this time.
 - c. Repeat the previous steps to install the passenger/right side Mounting Bracket.**Models with threaded inserts:**
 - a. Select the Driver/left side Mounting Bracket, **(Figure 6)**. Attach the Bracket to the threaded holes on the inside of the frame using the provided (2) 10mm Hex Bolts, (2) 10mm Lock Washers and (2) 10mm Flat Washers, **(Figure 6)**. Do not tighten hardware at this time
 - b. Repeat the previous step to install the passenger/right side Mounting Bracket.
4. Move to the top of the driver/left side of the frame to install the Support Bracket. Locate and remove the long factory bolt going through the bumper bracket and frame, **(Figure 8)**. **WARNING! DO NOT** remove both factory bolts at once or bumper may fall. Install one side at a time to avoid possible injury or damage to vehicle. Select the Driver/left side Support Bracket. Reuse the long factory bolt to attach the Support Bracket to the inside of the frame, **(Figure 9)**. Snug but do not tighten hardware.
5. Repeat **Step 4** to install the passenger/right side Support Bracket.
6. With assistance, lift the Grille Guard up to the outside of the Mounting Brackets. Line up the holes in the Mounting Brackets with the holes in the Grille Guard. Attach the Grille Guard to the Mounting Brackets with (6) 12mm Hex Bolts, (12) 12mm Flat Washers and (6) 12mm Nylon Lock Nuts, **(Figures 10 & 11)**. Push the grille guard back into an upright position. Secure the Support Brackets to the inside of the grille guard with the included (2) 10mm Button Head Bolts, (4) 10mm Flat Washers and (2) 10mm Nylon Lock Nuts, **(Figures 12 & 13)**. Snug but do not tighten all of the hardware.
7. Stand back from the vehicle and check to see that the Grille Guard is centered and level on the vehicle and adjust as required. It may be necessary to slightly loosen the Mounting Brackets to properly align the Grille Guard. **IMPORTANT:** Once properly aligned, fully tighten all Bracket to vehicle hardware only. If reinstalling fill panel and/or plastic splash guard then temporarily remove the Grille Guard. Otherwise, fully tighten all hardware at this time and proceed to the last step.
8. **To reinstall the plastic fill panel:**
 - a. Hold the fill panel up to the Support Brackets. Cut along the approximate area as indicated on the fill panel to clear the Support Brackets, **(Figure 14)**. **NOTE:** Only cut enough to clear the Brackets. DO not cut completely through the front edge of the fill panel.
 - b. Temporarily remove the Support Brackets. **WARNING!** To avoid possible injury or damage to vehicle, use stands or blocks to hold the Bumper up when removing the factory bolts. Reinstall the fill panel. Slide the Support Brackets through the fill panel cut outs, trim as required, and reinstall Support Brackets, see **Steps 4 & 5**.
 - c. Tighten fill panel hardware.

9. To reinstall the plastic splash guard:

- a. Hold the plastic splash guard up in its original position against the Mounting Brackets. Mark the location of the Mounting Brackets onto the inside of the splash guard, **(Figure 15)**.
- b. Cut out the sections to clear the Mounting Brackets. **IMPORTANT:** To maintain strength, remove as little material from the plastic splash guard as possible. Do not cut completely through the bottom edge of the splash guard.
- c. Temporarily remove the Mounting Brackets. Reattach the top of the splash guard using the factory hardware, **(Figure 1)**. Slide the Mounting Brackets through the splash guard cut outs, trim as required, and reinstall both Mounting Brackets, see **Step 3**.
- d. Next, locate the mounting location for the driver/left side Splash Guard Bracket, **(Figure 16)**. **NOTE:** Both Splash Guard Brackets look similar but each one is unique. Use **Figure 17** to help identify the correct Bracket. Reuse the metal plate factory bolt to attach the Bracket to the front of the frame, **(Figures 2 & 18)**. Leave hardware loose at this time.
- e. Repeat the previous step for passenger/right side Splash Guard Bracket installation.
- f. Align the Splash Guard Brackets with the bottom of the splash guard. Secure the bottom of the splash guard to the Brackets using the provided (2) 8mm Hex Bolts, (4) 8mm Flat Washers and (2) 8mm Nylon Lock Nuts, **(Figure 18)**. Tighten all splash guard hardware.

10. Repeat **Steps 6 & 7** to reinstall the Grille Guard and fully tighten all hardware.

11. Do periodic inspections of the installation to make sure that all hardware is secure and tight.

Continue to Page 5 for installation photos and diagrams.

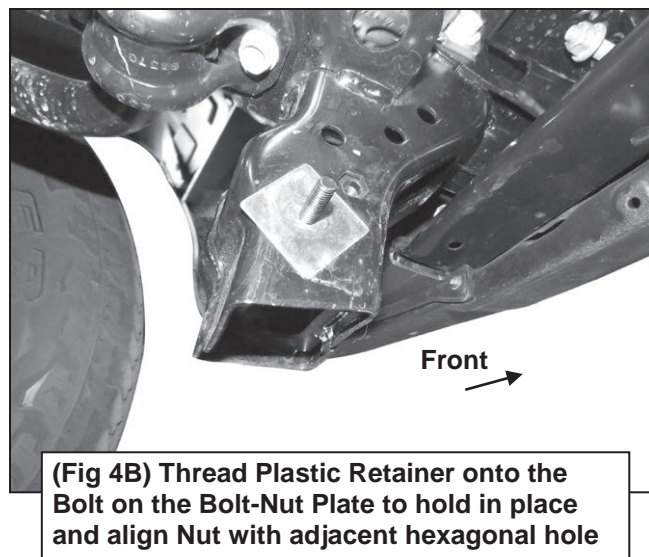
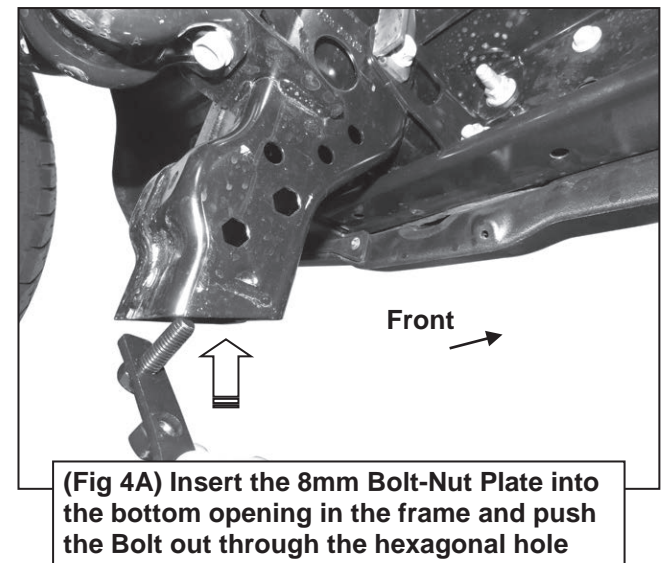
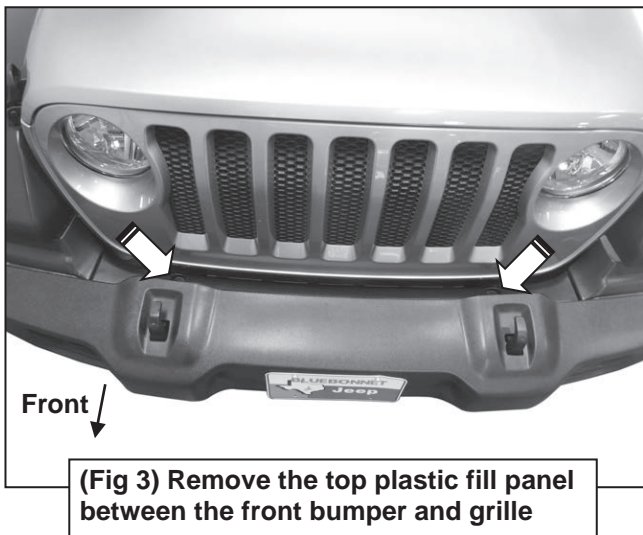
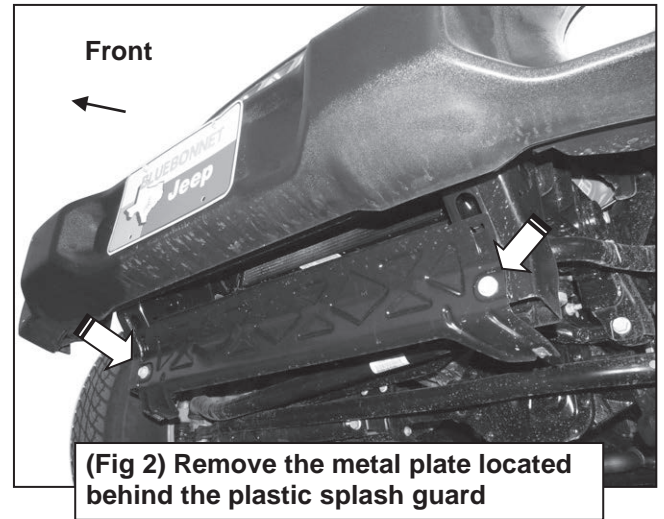
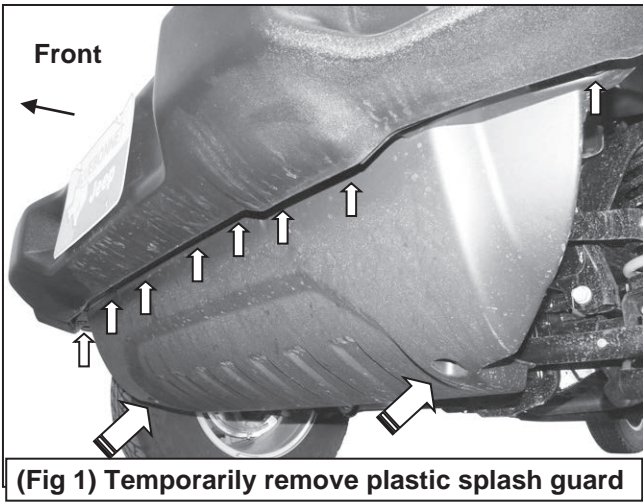

Driver/left Side Installation Pictured

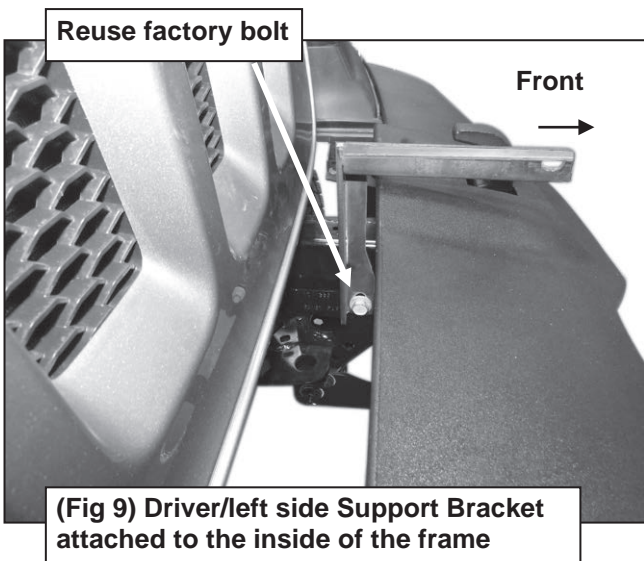
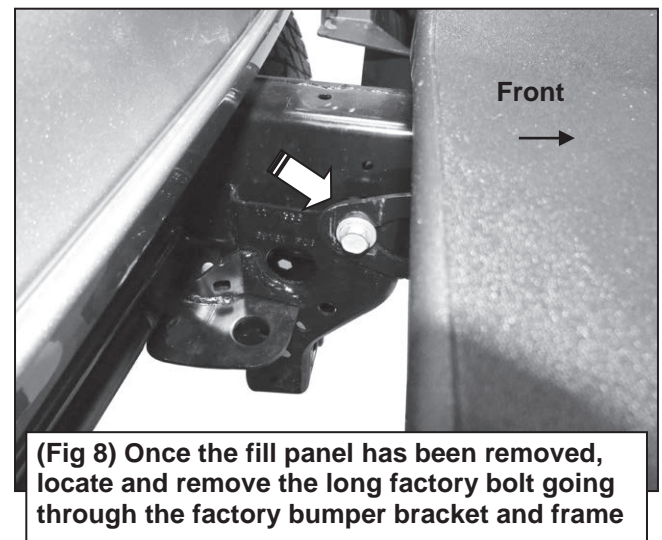
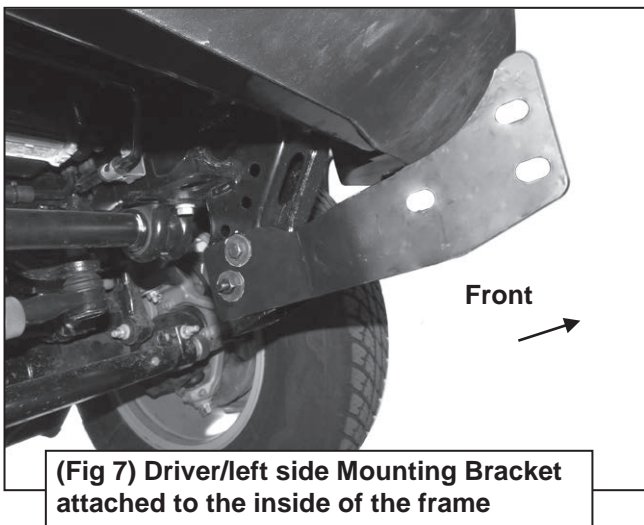
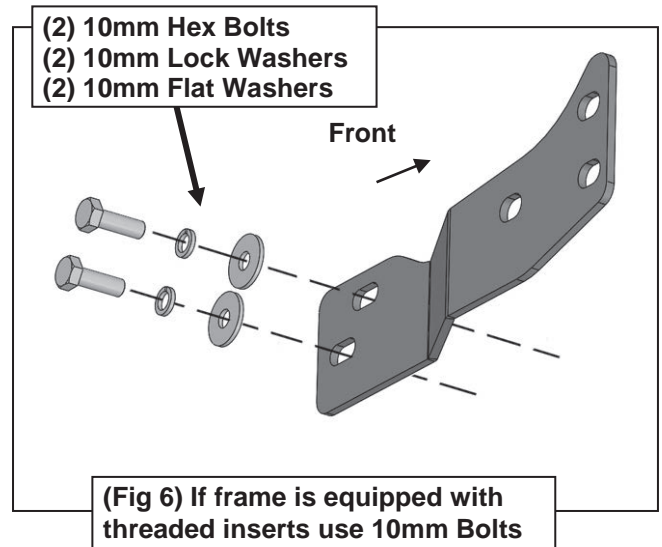
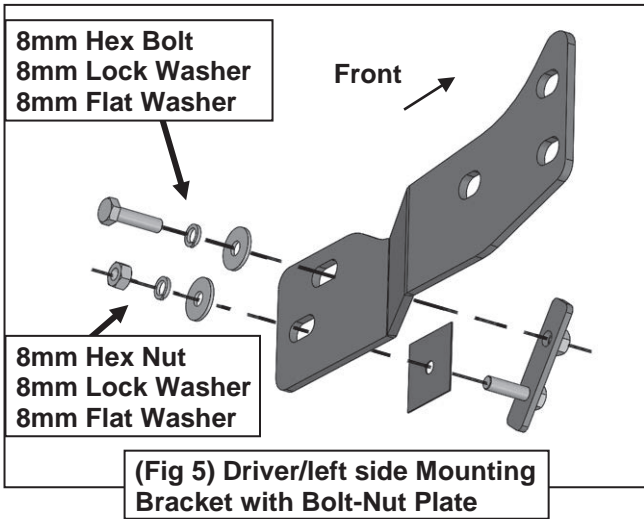

WARNING! DO NOT remove both factory bolts at once or bumper may fall. Install one side at a time to avoid possible injury or damage to vehicle.

Driver/left Side Installation Pictured

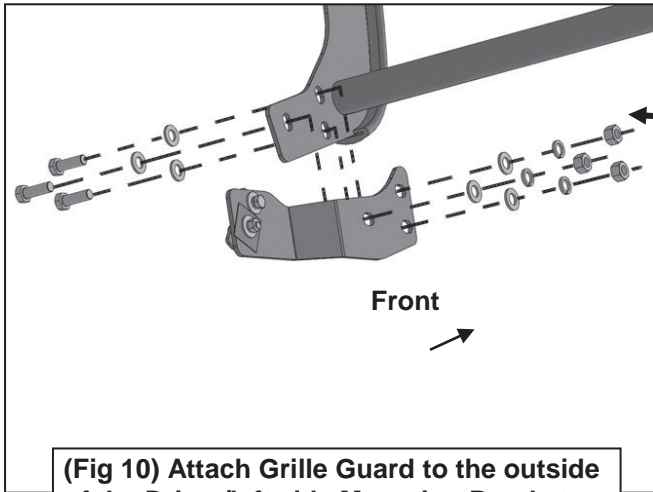

- (3) 12mm Hex Bolts
- (6) 12mm Flat Washers
- (3) 12mm Lock Washers
- (3) 12mm Hex Nuts

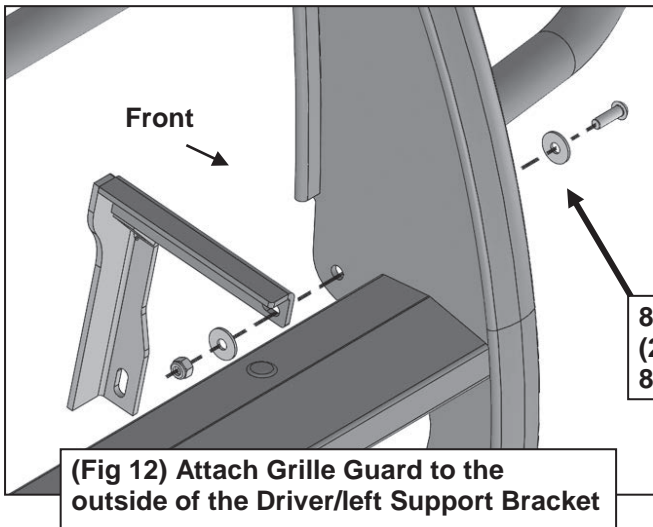
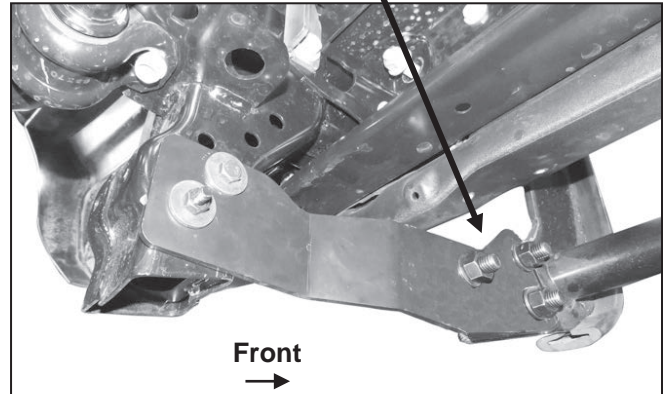

- 8mm Button Head Bolt
- (2) 8mm Flat Washers
- 8mm Nylon Lock Nut

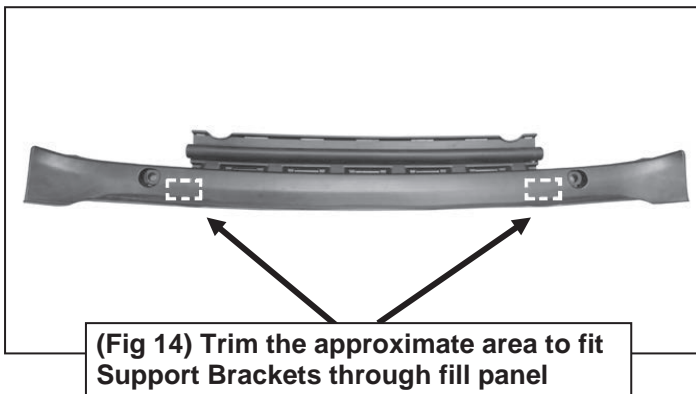
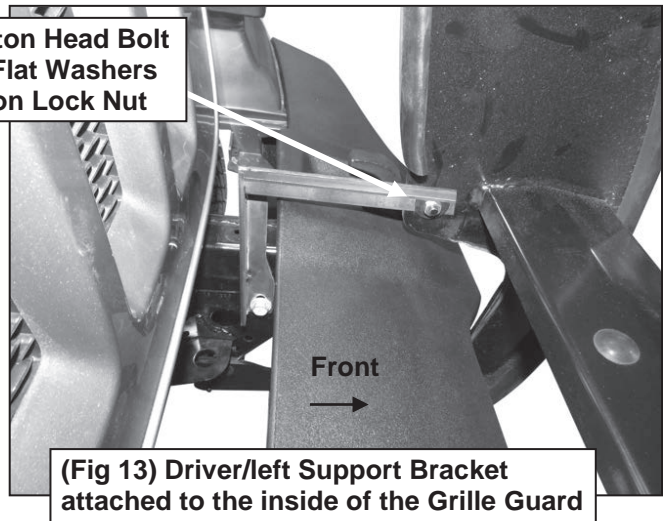

Driver/left Side Installation Pictured



(Fig 15) Trim the approximate area to clear the Mounting Brackets through the splash guard

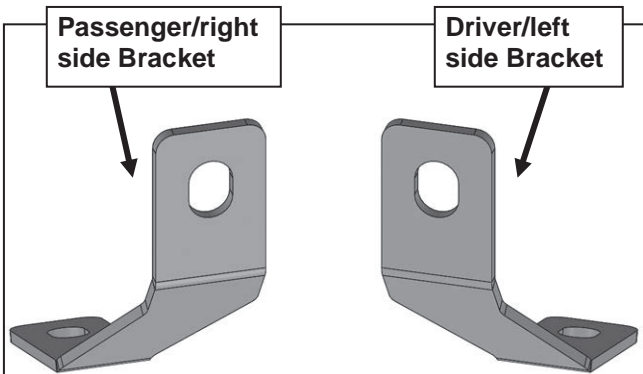

(Fig 17) Splash Guard Brackets



Temporarily, remove Grille Guard only. Hold the splash guard up in position against the Mounting Brackets. Mark the cut area on the inside of the cover. Start with a small opening and slowly enlarge the opening to get the best fit around the brackets. Area cut from cover pictured for example only.

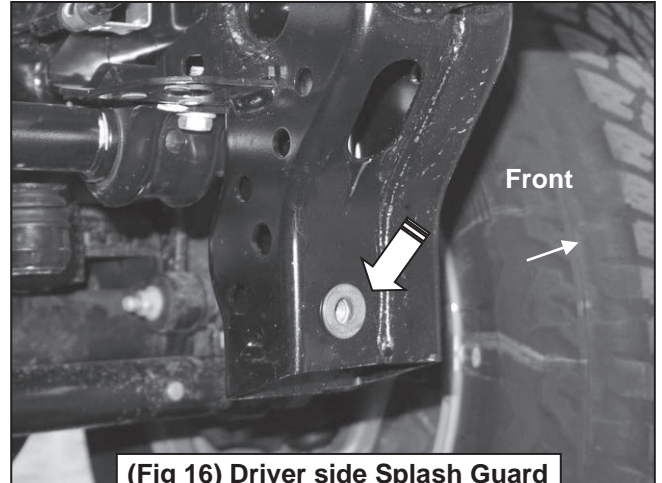

(Fig 16) Driver side Splash Guard Bracket mounting location

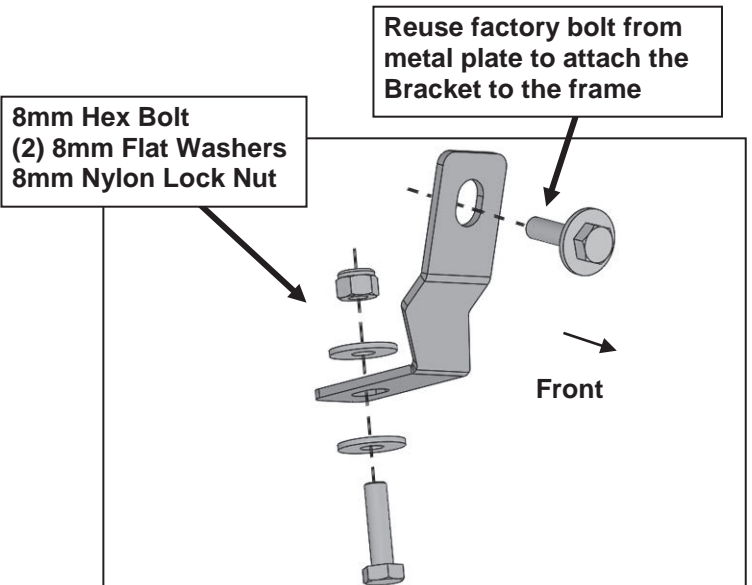

(Fig 18) Attach Driver/left side Splash Guard Bracket to frame and splash guard