

# Installation Instructions

# 35701

## Level of Difficulty

Easy

## Parts List

1	Driver / left 3" sidebar
1	Passenger / right 3" sidebar
1	Driver / left front mounting bracket
1	Passenger / right front mounting bracket
1	Driver / left center mounting bracket
1	Passenger / right center mounting bracket
1	Driver / right rear mounting bracket
1	Passenger / right rear mounting bracket
1	Driver / left front support bracket
1	Passenger / right front support bracket
2	Driver / left center & rear support bracket
2	Passenger / right center & rear support brackets
12	Hex bolts, 6 - 1.0mm x 25mm
24	Flat washers, M6 x 22mm x 2mm
12	6 - 1.0mm Nylock nuts
6	Hex bolts, 8 - 1.25mm x 35mm
12	Combo bolts, 8 - 1.25mm
6	Flat washers, M8 x 28mm x 3mm
6	Lock washers, M8
6	Hex bolts, 10 - 1.5mm x 30mm
12	Flat washers, M10 x 24mm x 2mm
6	Nylock nuts, 10 - 1.5mm

## Torque Specifications

	Metric	SAE
	M6 bolt	3 ft.-lbs.
	M8 bolt	7 ft.-lbs.
	M10 bolt	16 ft.-lbs.
	M12 bolt	28 ft.-lbs.
	1/4" bolt	3 ft.-lbs.
	5/16" bolt	7 ft.-lbs.
	3/8" bolt	16 ft.-lbs.
	7/16" bolt	20 ft.-lbs.
	1/2" bolt	28 ft.-lbs.

Use above torque setting unless otherwise noted

## Product Photo



## Brackets and Hardware

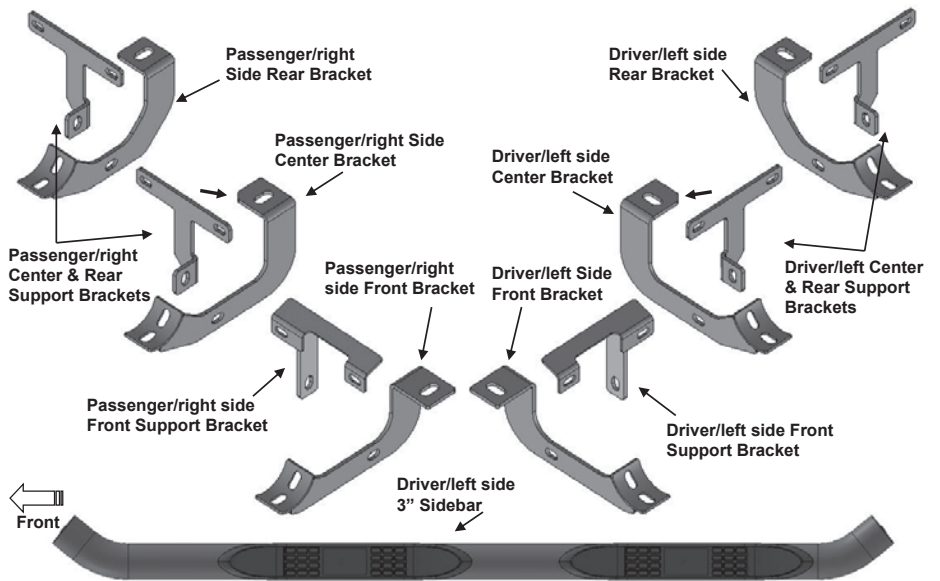

## Notes and Maintenance

Before you begin installation, read all instructions thoroughly.

Proper tools will improve the quality of installation and reduce the time required.

To protect the product, wax after installing. Regular waxing is recommended to add a protective layer over the finish. Do not use any type of polish or wax that may contain abrasives that could damage the finish.

For polished, gloss and other smooth finishes, polish may be used to clear small scratches and scuffs on the finish.

Mild automotive detergent may be used to clean the product. Do not use dish detergent, abrasive cleaners, abrasive pads, wire brushes or other similar products that may damage the finish.

Refer to the table to the left when securing hardware during the installation process to help prevent damage to the product or vehicle.

## PROCEDURE:

1. REMOVE CONTENTS FROM BOX. VERIFY ALL PARTS ARE PRESENT. READ INSTRUCTIONS CAREFULLY BEFORE STARTING INSTALLATION. FACTORY INSTALLED OR AFTERMARKET "ROCK RAILS," SIDE STEPS OR RUNNING BOARDS MUST BE REMOVED.
2. Start installation toward the front of the driver side of the vehicle and find the front threaded insert located in between the first pair of holes along the pinch weld, (Figure 1).
3. Select the Driver/left side Front Mounting Bracket, (Figure 2). **IMPORTANT:** Use the illustration above and Figure 3 to properly identify the Mounting Bracket. Attach the Bracket to the threaded insert using (1) 8mm Hex Bolt, (1) 8mm Lock Washer and (1) 8mm Flat Washer, (Figure 3). Do not tighten hardware at this time.
4. Next, select the Driver/left side Front Support Bracket, (Figure 4). **IMPORTANT:** Use the illustration above to help identify the correct Support Bracket. Align the Bracket to the back of the pinch weld and to the rear side of the Front Mounting Bracket. Attach the Support Bracket to the pinch weld using (2) 6mm Hex Bolts, (4) 6 mm Flat Washers and (2) 6mm Nylon Lock Nuts, (Figures 4 & 5). **NOTE:** Insert bolts from the outside of the pinch weld and through the Bracket. Use (1) 10mm Hex Bolt, (2) 10mm Flat Washers and (1) 10mm Nylon Lock Nut to secure the Support Bracket to the Mounting Bracket, (Figures 4 & 5). Do not tighten hardware at this time.
5. Move along the body panel to the center mounting location and locate the threaded insert and pair of holes on the pinch weld, (Figure 6). Repeat Steps 3 & 4 to install the Center Brackets, (Figures 8 & 9). **NOTE:** The Center and Rear Mounting Brackets look similar but each one is unique. Notice the bottom corner trim on the Center Mounting Bracket in the illustration above and Figure 7.
6. Move to the last, rear, mounting location and locate the threaded insert and pair of holes on the pinch weld, (Figure 10). Repeat Steps 3 & 4 to install the Rear Brackets, (Figures 11 & 12). **NOTE:** The Center and Rear Mounting Brackets look similar but each one is unique. Notice the rounded corners on the Rear Mounting Bracket in the illustration above and Figure 7.
7. Select the Driver/left Sidebar. Use the illustration above to select the correct Sidebar. Carefully position the Sidebar onto the (3) Mounting Brackets. **IMPORTANT:** Do not slide, (front to back or rotate), the Sidebar on the Brackets or damage to the finish on the Sidebar may result. Attach the Sidebar to the Mounting Brackets with (6) 8mm x 25mm Combination Hex Bolts, (Figures 13—15). Do not tighten hardware. **NOTE:** Mounting cradles on Brackets should be inline and pointing toward the rear of the vehicle for proper installation. Snug all hardware but do not tighten.
8. Level and adjust the Sidebar and tighten all hardware.
9. Repeat Steps 1—8 for Passenger/right Sidebar installation.
10. Do periodic inspections to the installation to make sure that all hardware is secure and tight.

To protect your investment, wax this product after installing. Regular waxing is recommended to add a protective layer over the finish. Do not use any type of polish or wax that may contain abrasives that could damage the finish. Mild soap may be used to clean Sidebar.

### Driver/Left Side Installation Pictured

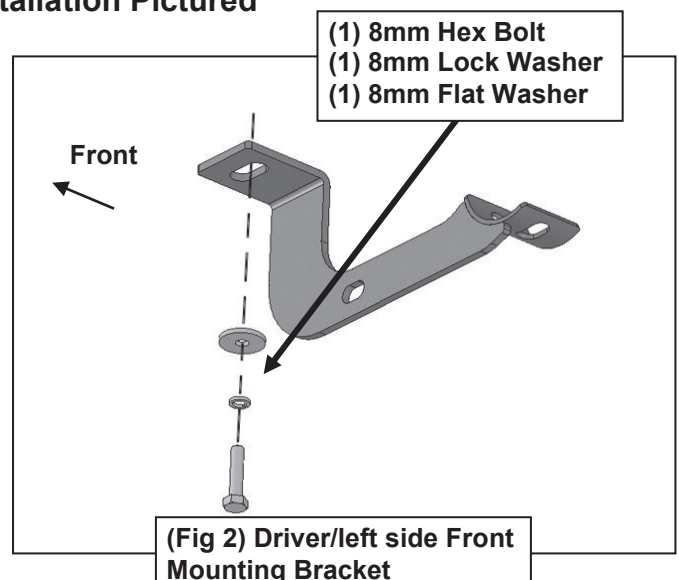
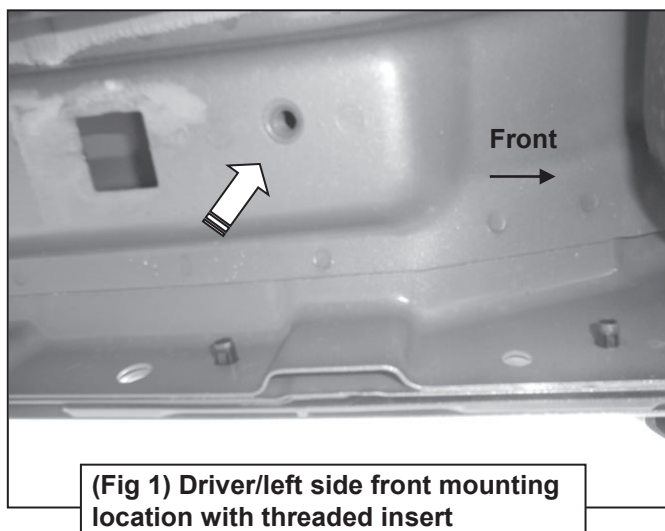

## Driver/Left Side Installation Pictured

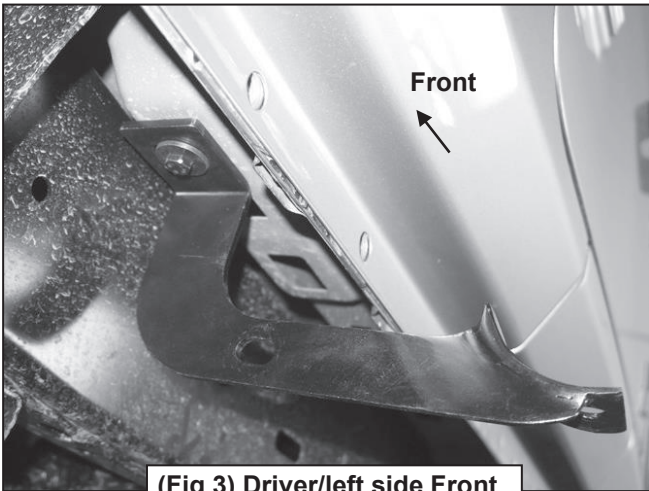

(Fig 3) Driver/left side Front Mounting Bracket installed

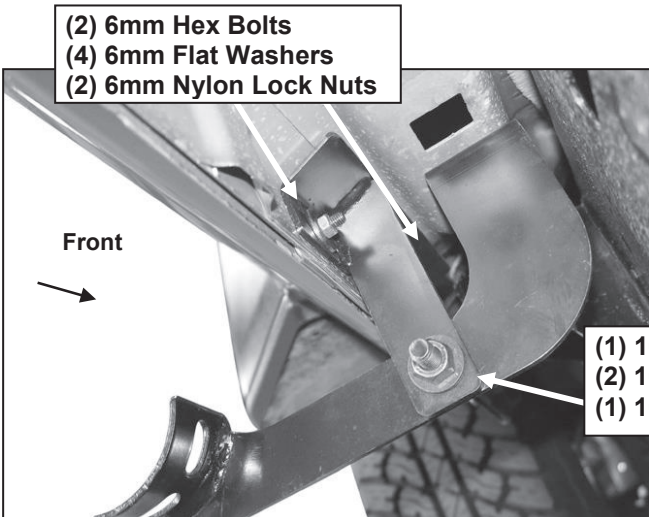

(Fig 5) Attach Support Bracket to back of pinch weld and to rear side of Mounting Bracket

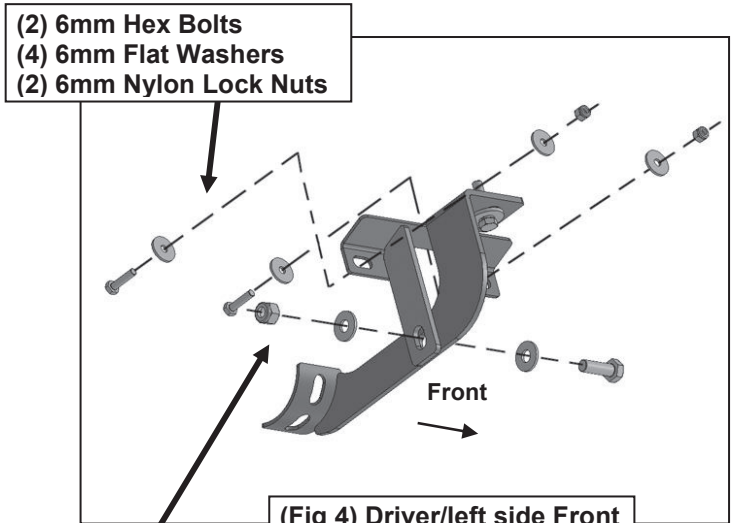

(Fig 4) Driver/left side Front Support Bracket

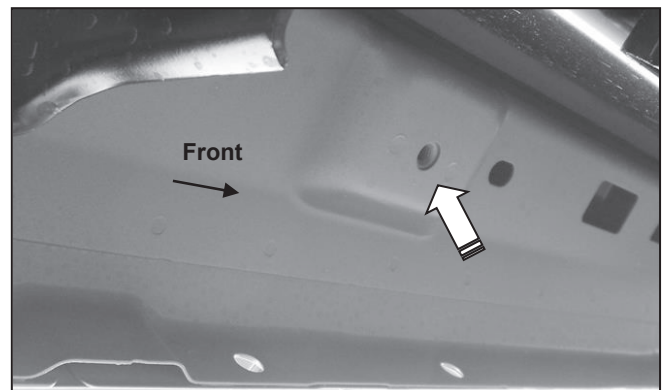

(Fig 6) Driver/left side center mounting location

# Driver/left Side Installation Pictured

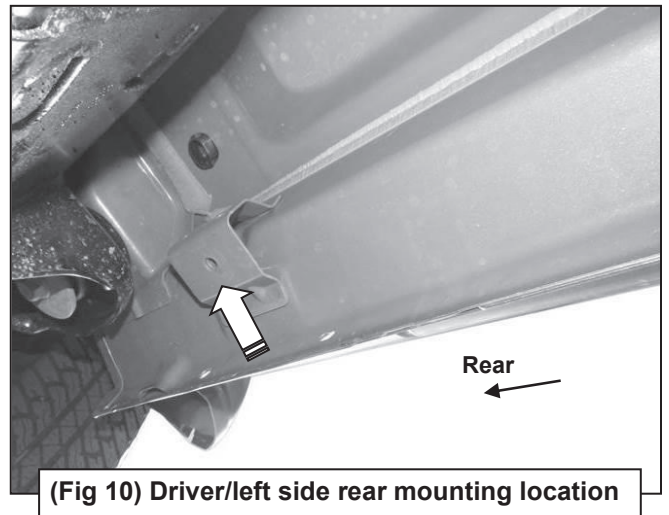
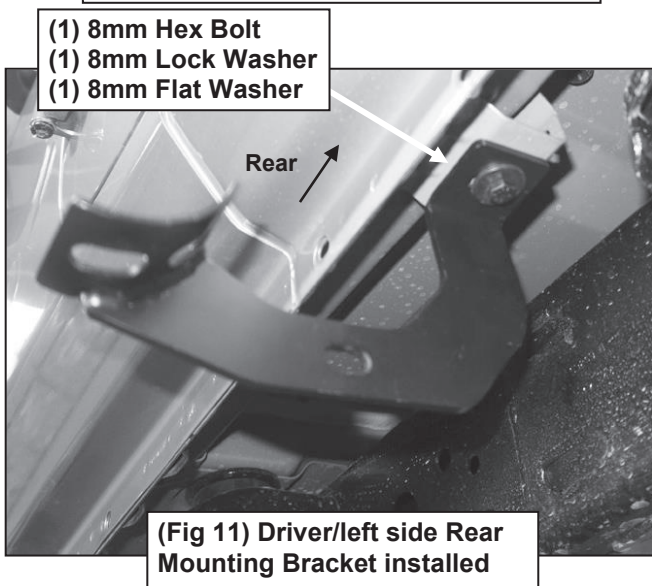
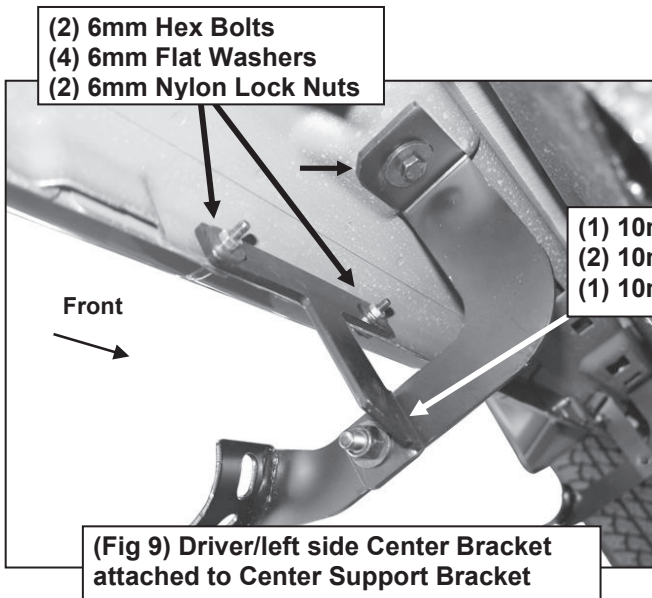
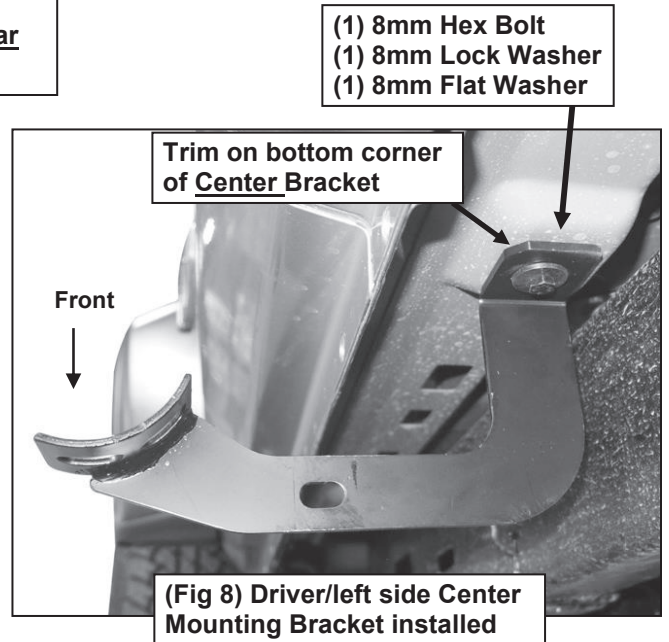
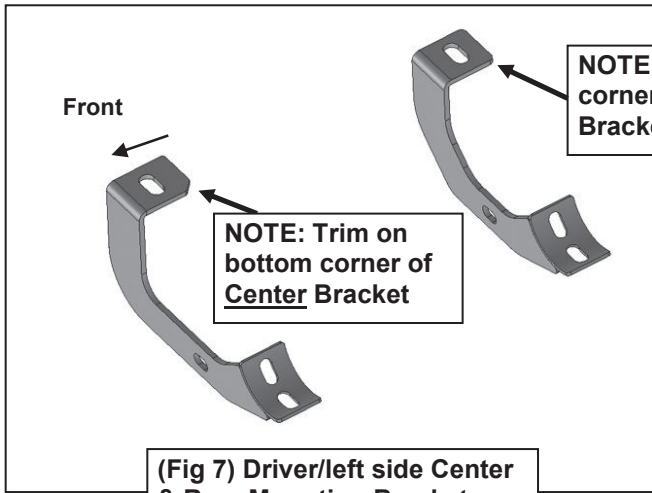

## Driver/left Side Installation Pictured

- (2) 6mm Hex Bolts
- (4) 6mm Flat Washers
- (2) 6mm Nylon Lock Nuts

- (1) 10mm Hex Bolt
- (2) 10mm Flat Washers
- (1) 10mm Nylon Lock Nut

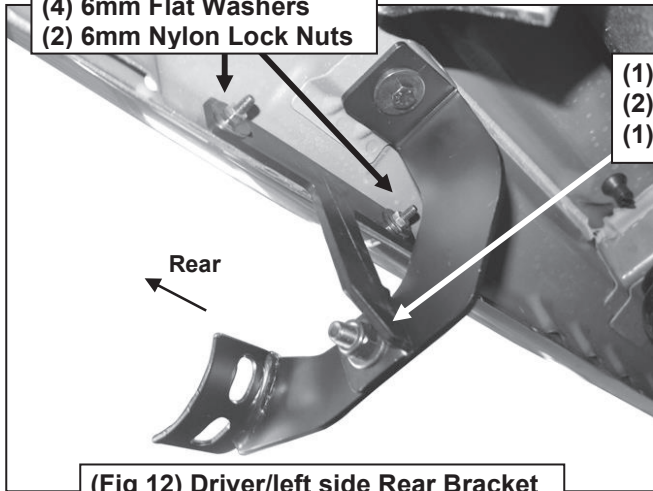

(Fig 12) Driver/left side Rear Bracket attached to Rear Support Bracket

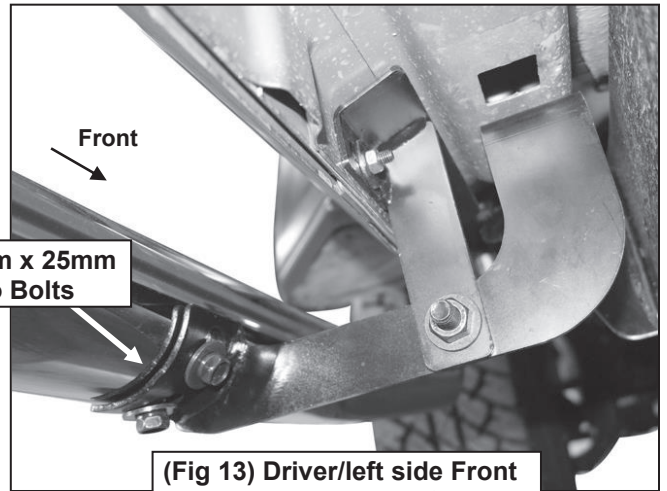

- (2) 8mm x 25mm Combo Bolts

(Fig 13) Driver/left side Front Brackets attached to Sidebar

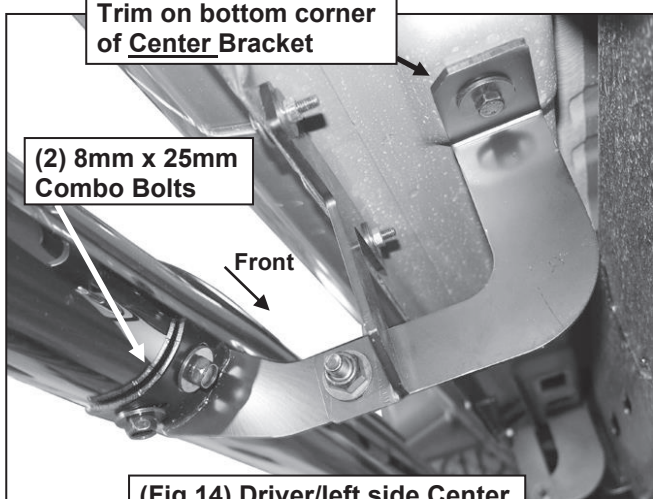

Trim on bottom corner of Center Bracket

- (2) 8mm x 25mm Combo Bolts

(Fig 14) Driver/left side Center Brackets attached to Sidebar

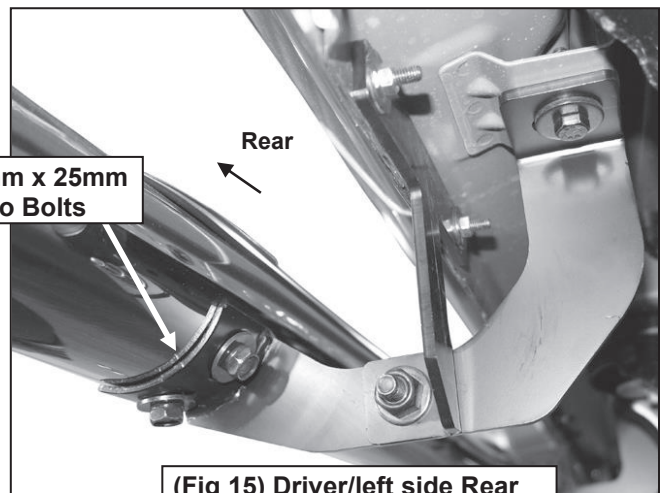

- (2) 8mm x 25mm Combo Bolts

(Fig 15) Driver/left side Rear Brackets attached to Sidebar

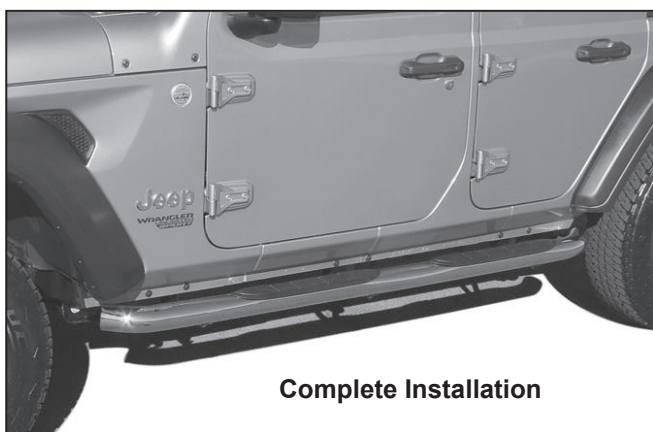

Complete Installation